

GODDARD SCHOOL OF BRYANT
DRAINAGE REPORT

Date: 03-25-2026

Located in: Bryant, Arkansas

Prepared for:
City of Bryant, Arkansas

Prepared by:

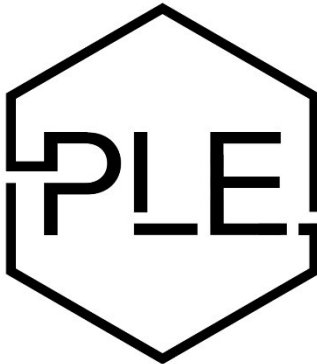

PHILLIP LEWIS ENGINEERING

Structural + Civil Consultants

23620 Interstate 30 | Bryant, AR
PH: 501-350-9840

CERTIFICATION

I hereby state that this Final Drainage has been prepared by me or under my supervision and meets the standard of care and expertise which is usual and customary in this community of professional engineers. The analysis has been prepared utilizing procedures and practices by the City of Bryant and within the standard accepted practices.



Phillip A. Lewis, PE.

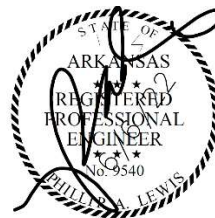
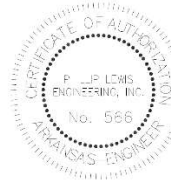

DATE: 03-25-2026

PROJECT LOCATION MAP



DESCRIPTION OF PROPERTY

The proposed project is for the construction of the Goddard School of Bryant located on Christy Lane, Alexander, AR. The proposed development is a 9,000 sq. ft. building, parking lot, and outdoor playground.

The intent of this drainage analysis is to reevaluate the previous drainage design and ensure that the completion of this development still meets the design intent and capacity of the previous constructed onsite detention facility located at the corner of Henry Avenue and Bryant Parkway.

Per previous drainage calculations performed for the construction of the existing pond, the existing ground coverage for the entire development drainage basin consisted of and partially still consists of natural vegetation (3%-8% slope), hydrologic soil group C/D (C = 0.50).

According to FEMA Flood Insurance Rate Map, Panel 05125C0240E, this property lies within Zone X, areas determined to be outside the 0.2% annual chance floodplain. A copy of the map can be found in the appendix.

DRAINAGE CRITERIA

In accordance with the requirements of the City of Bryant, the proposed developments drainage plan and this drainage report were developed with the criteria established in the Bryant Stormwater Management & Drainage Manual provided on cityofbryant.com.

All drainage calculations were performed using HydroCAD software to determine and analyze the changes in stormrunoff volume, flow rates, and design the outlet release structure. Hydraflow Express software was used to appropriately design and size all storm sewer inlets, pipes and channels.

Calculations were performed using the Rational Method, using NOAA rainfall data, and the pond volume and outlet structure was analyzed for the 100-year storm event while the outlet structure is expected to match or reduce pre-development flow rates for all storm events: 2-yr, 10-yr, 25-yr, and 100-yr storms.

DESCRIPTION OF PREVIOUS DETENTION FACILITIES

Phillip Lewis Engineering has evaluated the previously supplied drainage analysis and made site investigations to fully understand the current drainage situation.

The previous drainage analysis studied the pre vs. post scenarios as a single 8.5 acre node. Post development was studied as one node routing through the detention pond that is now constructed on the site. Due to the nature of how construction phasing has evolved, some areas were not routed to this detention pond. Some of these areas ultimately discharge to locations that bypass the detention basin. Additionally, we believe that the current pond actually was intended to capture approximately 10 acres, which encompasses the Goddard facility, Christy Lane, Summerwood Offices, and Genwealth Financial Services.

This drainage study is intended to account for these discrepancies and ensure that the detention basin is throttling appropriately for the current and proposed increases in runoff. Additionally, within this design, the intent is to capture open pipe discharges (intended for pond capture) and route them correctly through adequate storm sewer.

PROPOSED DRAINAGE SYSTEM

This development is designed to capture the majority of runoff within the parking lot curb and gutter, collecting stormwater with standard curb inlets and downspout collector pipes. New storm sewer onsite will connect to an existing storm junction box on Christy Lane, ultimately discharging into the existing detention pond. The detention pond will remain in place as constructed. This drainage analysis will provide supporting evidence to validate the previously constructed detention basin's functionality.

The detention pond was designed to detain stormwater volumes based off the 100-yr storm events with a concrete overflow spillway to release water if a rainfall event were to exceed the 100-yr storm event. The outlet control structures are detailed within this report.

Overall Regional Study Pre vs. Post Summary

Storm Event	Pre-development Discharge (cfs)	Post-development Discharge w/o Detention (cfs)	Post-development Discharge w/ Detention (cfs)
2-yr	16.26	23.74	15.57
5-yr	19.47	28.27	17.90
10-yr	21.93	31.95	19.81
25-yr	25.26	26.64	22.19
100-yr	30.06	43.78	25.43

Goddard Site Pre vs. Post Summary

Storm Event	Pre-development Discharge (cfs)	Post-development Discharge w/o Detention (cfs)
2-yr	6.27	8.55
5-yr	7.50	10.18
10-yr	8.45	11.51
25-yr	9.73	13.20
100-yr	11.59	15.77

Overall pre development and post development discharge rates are displayed in the following hydrographs. A final discharge link has been added to show one comparable discharge number.

DRAINAGE BASIN MAPS

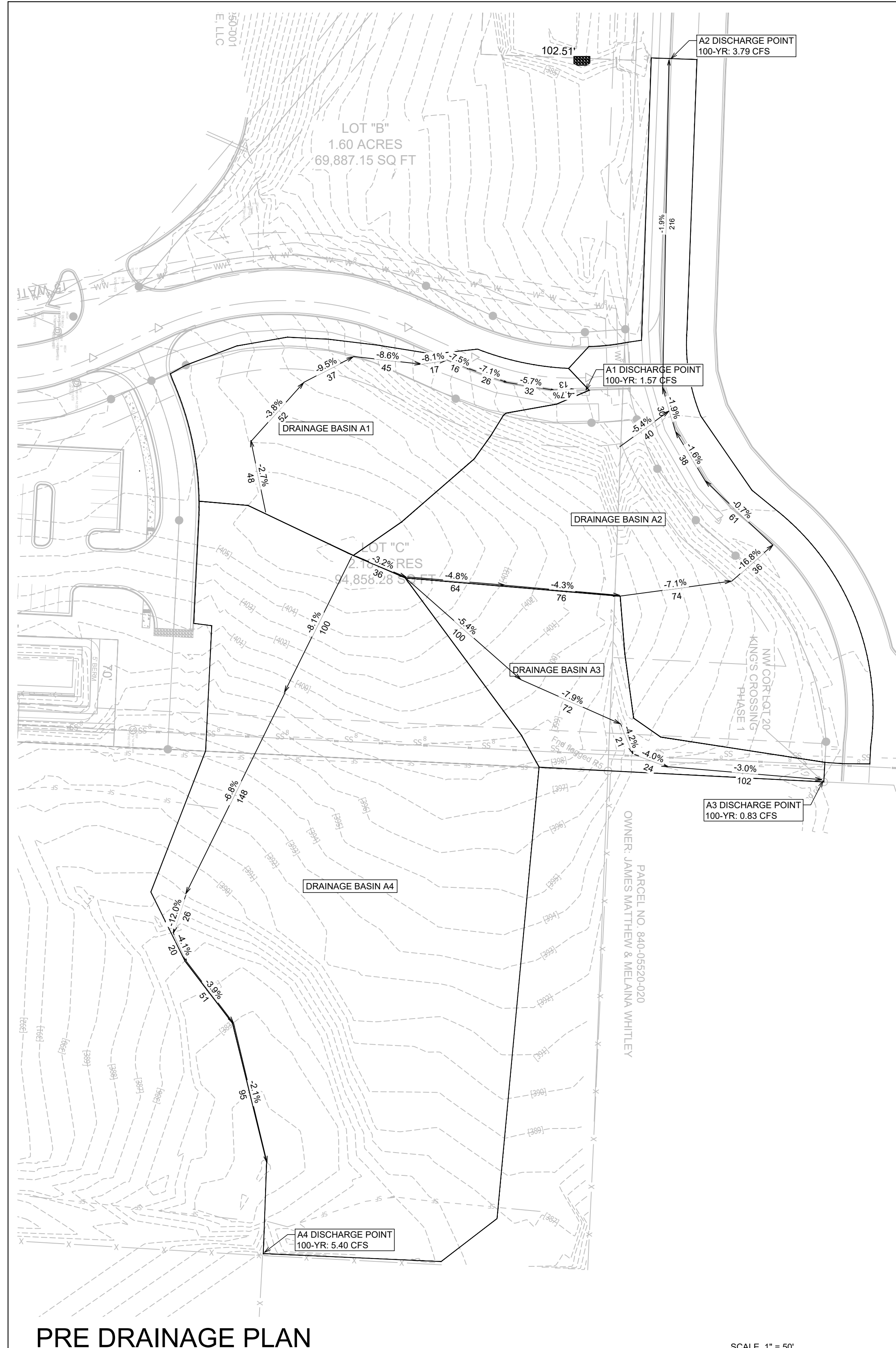

DRAINAGE BASINS AREAS

DRAINAGE BASIN	PERVIOUS	IMPERVIOUS
A1	20,204	3,399
A2	37,816	14,559
A3	13,861	0
A4	90,137	0

PRE DRAINAGE PLAN

SCALE 1" = 50'

GENERAL CONSTRUCTION NOTES

- A. THE CONTRACTOR WILL BE HELD SOLELY RESPONSIBLE FOR DAMAGES OCCURRING TO ANY PROPERTY DURING THE CONSTRUCTION OF THIS PROJECT. SAID CONTRACTOR SHALL TAKE ALL NECESSARY PRECAUTIONS TO PREVENT PROPERTY DAMAGE.
- B. IN ACCORDANCE WITH GENERALLY ACCEPTED CONSTRUCTION PRACTICES, THE CONTRACTOR WILL SOLELY AND COMPLETELY BE RESPONSIBLE FOR CONDITIONS OF THE JOB SITE, INCLUDING SAFETY WORK. THIS REQUIREMENT WILL APPLY CONTINUOUSLY AND WILL NOT BE LIMITED TO NORMAL WORKING HOURS.
THE DUTY OF BRYANT TO CONDUCT CONSTRUCTION INSPECTION REVIEWS OF THE CONTRACTOR'S PERFORMANCE IS NOT AN INSPECTION OR REVIEW OF THE ADEQUACY OF THE CONTRACTOR'S SAFETY MEASURES IN, ON, OR NEAR THE CONSTRUCTION SITE.
- C. ALL WATER AND SEWER IMPROVEMENTS SHALL BE CONSTRUCTED IN ACCORDANCE WITH THE LATEST REVISION TO THE CITY OF BRYANT'S WATER AND WASTEWATER (SANITARY SEWER) STANDARD SPECIFICATIONS.
- D. THE CONTRACTOR IS SPECIFICALLY CAUTIONED THAT THE LOCATION AND/OR ELEVATION OF EXISTING UTILITIES AS SHOWN ON THESE PLANS IS BASED ON RECORDS OF THE VARIOUS UTILITY COMPANIES AND, WHERE POSSIBLE, MEASUREMENTS TAKEN IN THE FIELD. THE INFORMATION IS NOT TO BE RELIED ON AS BEING EXACT OR COMPLETE. THE CONTRACTOR MUST CALL THE APPROPRIATE UTILITY COMPANY AT LEAST 48 HOURS BEFORE ANY EXCAVATION TO REQUEST EXACT FIELD LOCATION OF ALL UTILITIES. IT SHALL BE THE RESPONSIBILITY OF THE CONTRACTOR TO LOCATE ALL EXISTING UTILITIES WHICH CONFLICT WITH PROPOSED IMPROVEMENTS SHOWN ON THE PLAN.
- E. CONTRACTOR IS TO REMOVE AND DISPOSE OF ALL DEBRIS, RUBBISH, AND OTHER MATERIALS RESULTING FROM PREVIOUS AND CURRENT DEMOLITION OPERATIONS. DISPOSAL WILL BE IN ACCORDANCE WITH ALL LOCAL, STATE AND/OR FEDERAL REGULATIONS GOVERNING SUCH OPERATIONS.
- F. PRIOR TO INSTALLATION OF ANY UTILITIES, THE CONTRACTOR IS TO EXCAVATE, VERIFY AND CALCULATE ALL CROSSINGS AND INFORM ANY AND ALL UTILITIES OF ANY CONFLICTS PRIOR TO CONSTRUCTION.
- G. CONSTRUCTION SHALL NOT START ON ANY WATER UTILITY TIE-INS UNTIL APPROVAL IS GIVEN BY BRYANT WATER. SAID CONTRACTOR SHALL NOT OPERATE ANY VALVE, HYDRANT, OR WATER UTILITY APPURTENANCE NOR SHALL HE ATTACH TO OR TAP ANY WATER UTILITY MAIN WITHOUT APPROVAL. THE CONTRACTOR SHALL BEAR THE COST AND CONSEQUENCE OF ANY DISRUPTION OF UTILITY OPERATION CAUSED BY CONSTRUCTION.
- H. FIBER OPTIC CABLE ON AND/OR ADJACENT TO THIS SITE WERE NOT LOCATED BY THE SURVEY AND ARE NOT SHOWN. IT IS THE RESPONSIBILITY OF THE CONTRACTOR TO LOCATE ANY FIBER OPTIC CABLES ASSOCIATED WITH THIS SITE AND TAKE ALL NECESSARY AND REQUIRED PRECAUTIONS TO PROTECT ANY EXISTING FIBER OPTIC CABLES. CONTRACTORS SHALL COORDINATE ALL EFFORTS WITH OWNER OF FIBER OPTIC CABLES OR THEIR DESIGNATED REPRESENTATIVE.
- J. THE CONTRACTOR IS RESPONSIBLE FOR CONTACTING "ONECALL" SERVICE TO MARK ALL UTILITIES PRIOR TO ANY DEMOLITION, EARTHWORK, OR UTILITY WORK ON THIS SITE.

PHILLIP LEWIS ENGINEERING, INC.
Structural + Civil Consultants
23620 Interstate 30 | Bryant, Arkansas
PH: 501-350-9840

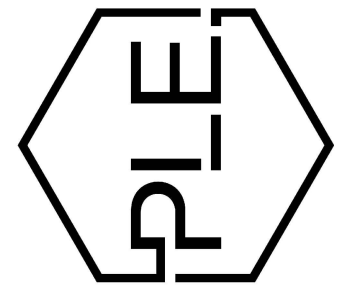

REVISION:

**THE GODDARD SCHOOL
OF BRYANT**
ALEXANDER, ARKANSAS

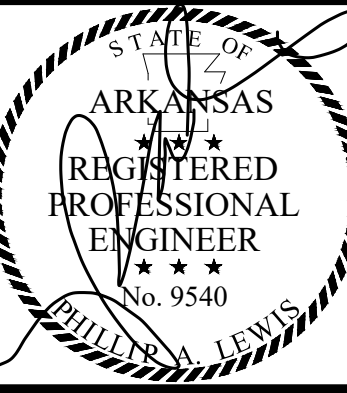
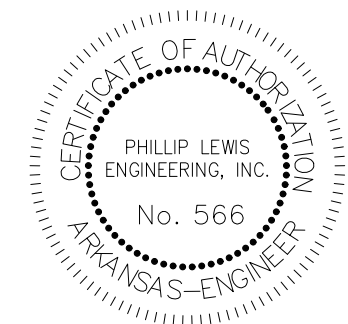

PROJECT NUMBER:

SHEET ISSUE DATE:
03-25-2026

PAGE TITLE:

**PRE
DRAINAGE
PLAN**

SHEET NUMBER:

C1.6

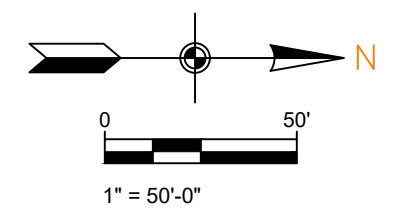



DRAINAGE BASINS AREAS

DRAINAGE BASIN	PERVIOUS	IMPERVIOUS
B1	74,165	602
B2	6,595	167
B3	18,730	14,559
B4	4,916	14,577
B5	0	9,275
B6	0	1,887
B7	12,580	8,589
B8	7,982	6,458
C1	6,135	14,202
C2	11,376	22,963
C3	0	3,480
C4	8,130	3,245
C5	1,634	5,061
C6	0	2,835
C7	0	1,597
C8	0	1,548
C9	4,456	9,361
C10	1,225	4,183
C11	2,876	3,307
C12	7,218	18,440
C13	1,558	6,388
C14	6,127	15,898
C15	0	13,450
C16	15,465	6,612
C17	56,749	0
C18	12,812	9,973
C19	18,009	0
C20	30,789	0

OVERALL DRAINAGE PLAN

SCALE 1" = 50'

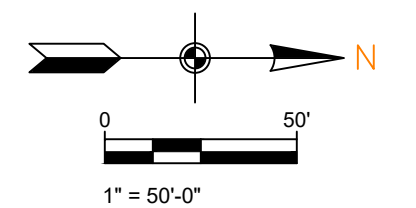

PHILLIP LEWIS ENGINEERING, INC.
 Structural + Civil Consultants
 23620 Interstate 30 | Bryant, Arkansas
 PH: 501-350-9840

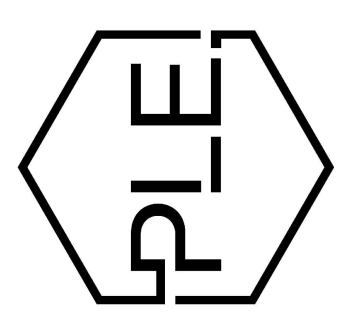

REVISION:

THE GODDARD SCHOOL OF BRYANT
 ALEXANDER, ARKANSAS

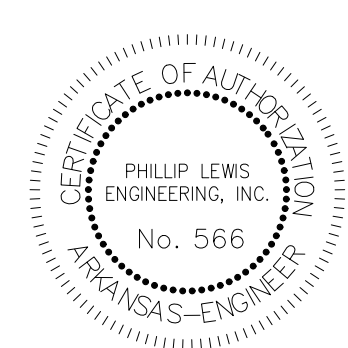

PROJECT NUMBER:

SHEET ISSUE DATE:
03-25-2026

PAGE TITLE:

OVERALL DRAINAGE PLAN

SHEET NUMBER:

C1.7

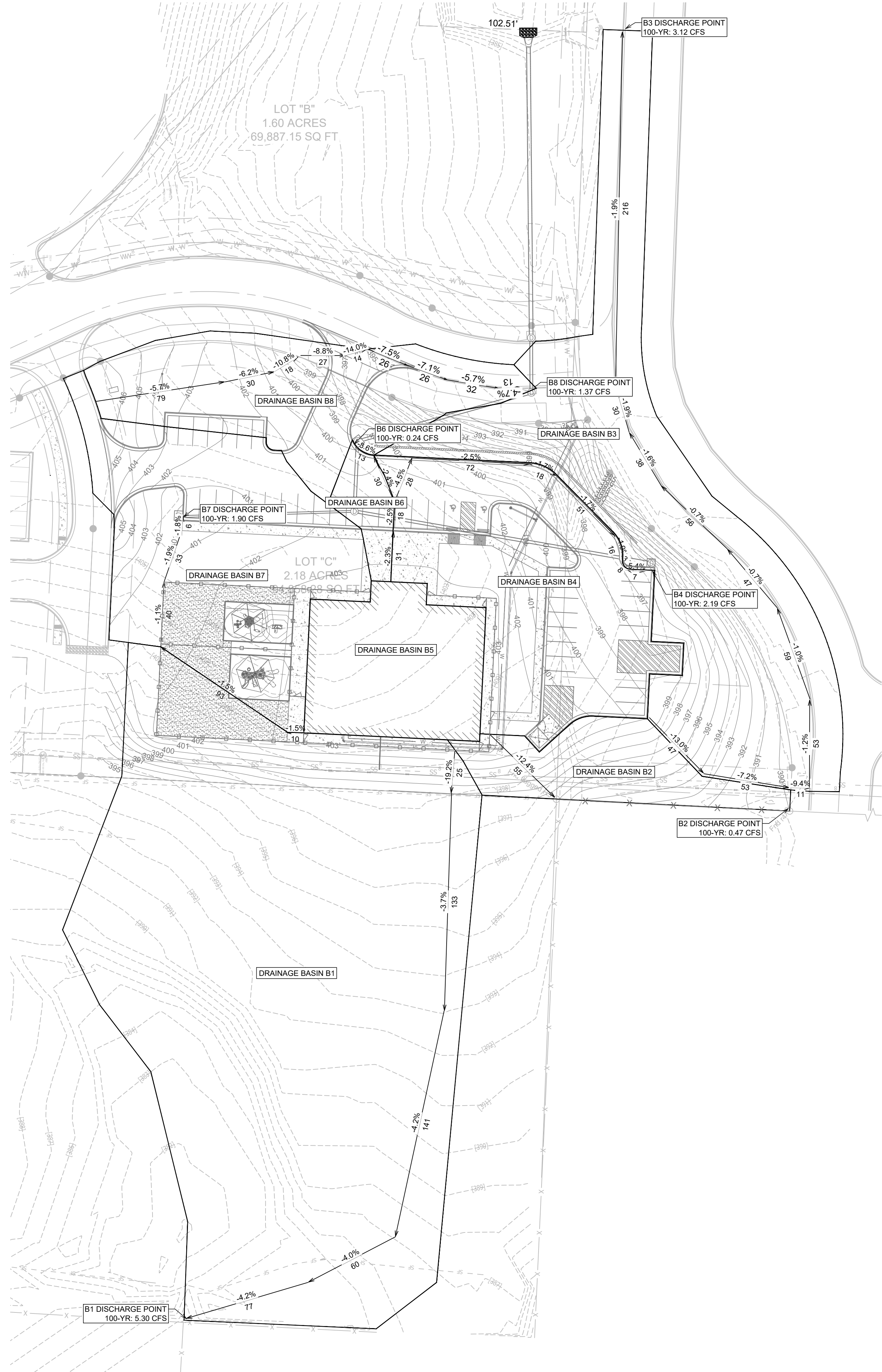

POST DRAINAGE PLAN

SCALE 1" = 40'

GENERAL CONSTRUCTION NOTES

- A. THE CONTRACTOR WILL BE HELD SOLELY RESPONSIBLE FOR DAMAGES OCCURRING TO ANY PROPERTY DURING THE CONSTRUCTION OF THIS PROJECT. SAID CONTRACTOR SHALL TAKE ALL NECESSARY PRECAUTIONS TO PREVENT PROPERTY DAMAGE.
- B. IN ACCORDANCE WITH GENERALLY ACCEPTED CONSTRUCTION PRACTICES, THE CONTRACTOR WILL SOLELY AND COMPLETELY BE RESPONSIBLE FOR CONDITIONS OF THE JOB SITE, INCLUDING SAFETY WORK. THIS REQUIREMENT WILL APPLY CONTINUOUSLY AND WILL NOT BE LIMITED TO NORMAL WORKING HOURS.

THE DUTY OF BRYANT TO CONDUCT CONSTRUCTION INSPECTION REVIEWS OF THE CONTRACTOR'S PERFORMANCE IS NOT AN INSPECTION OR REVIEW OF THE ADEQUACY OF THE CONTRACTOR'S SAFETY MEASURES IN, ON, OR NEAR THE CONSTRUCTION SITE.
- C. ALL WATER AND SEWER IMPROVEMENTS SHALL BE CONSTRUCTED IN ACCORDANCE WITH THE LATEST REVISION TO THE CITY OF BRYANT'S WATER AND WASTEWATER (SANITARY SEWER) STANDARD SPECIFICATIONS.
- D. THE CONTRACTOR IS SPECIFICALLY CAUTIONED THAT THE LOCATION AND/OR ELEVATION OF EXISTING UTILITIES AS SHOWN ON THESE PLANS IS BASED ON RECORDS OF THE VARIOUS UTILITY COMPANIES AND, WHERE POSSIBLE, MEASUREMENTS TAKEN IN THE FIELD. THE INFORMATION IS NOT TO BE RELIED ON AS BEING EXACT OR COMPLETE. THE CONTRACTOR MUST CALL THE APPROPRIATE UTILITY COMPANY AT LEAST 48 HOURS BEFORE ANY EXCAVATION TO REQUEST EXACT FIELD LOCATION OF ALL UTILITIES. IT SHALL BE THE RESPONSIBILITY OF THE CONTRACTOR TO LOCATE ALL EXISTING UTILITIES WHICH CONFLICT WITH PROPOSED IMPROVEMENTS SHOWN ON THE PLAN.
- E. CONTRACTOR IS TO REMOVE AND DISPOSE OF ALL DEBRIS, RUBBISH, AND OTHER MATERIALS RESULTING FROM PREVIOUS AND CURRENT DEMOLITION OPERATIONS. DISPOSAL WILL BE IN ACCORDANCE WITH ALL LOCAL, STATE AND/OR FEDERAL REGULATIONS GOVERNING SUCH OPERATIONS.
- F. PRIOR TO INSTALLATION OF ANY UTILITIES, THE CONTRACTOR IS TO EXCAVATE, VERIFY AND CALCULATE ALL CROSSINGS AND INFORM ANY AND ALL UTILITIES OF ANY CONFLICTS PRIOR TO CONSTRUCTION.
- G. CONSTRUCTION SHALL NOT START ON ANY WATER UTILITY TIE-INS UNTIL APPROVAL IS GIVEN BY BRYANT WATER. SAID CONTRACTOR SHALL NOT OPERATE ANY VALVE, HYDRANT, OR WATER UTILITY APPURTENANCE NOR SHALL HE ATTACH TO OR TAP ANY WATER UTILITY MAIN WITHOUT APPROVAL. THE CONTRACTOR SHALL BEAR THE COST AND CONSEQUENCE OF ANY DISRUPTION OF UTILITY OPERATION CAUSED BY CONSTRUCTION.
- H. FIBER OPTIC CABLE ON AND/OR ADJACENT TO THIS SITE WERE NOT LOCATED BY THE SURVEY AND ARE NOT SHOWN. IT IS THE RESPONSIBILITY OF THE CONTRACTOR TO LOCATE ANY FIBER OPTIC CABLES ASSOCIATED WITH THIS SITE AND TAKE ALL NECESSARY AND REQUIRED PRECAUTIONS TO PROTECT ANY EXISTING FIBER OPTIC CABLES. CONTRACTORS SHALL COORDINATE ALL EFFORTS WITH OWNER OF FIBER OPTIC CABLES OR THEIR DESIGNATED REPRESENTATIVE.
- J. THE CONTRACTOR IS RESPONSIBLE FOR CONTACTING "ONECALL" SERVICE TO MARK ALL UTILITIES PRIOR TO ANY DEMOLITION, EARTHWORK, OR UTILITY WORK ON THIS SITE.

PHILLIP LEWIS ENGINEERING, INC.
Structural + Civil Consultants
23620 Interstate 30 | Bryant, Arkansas
PH: 501-350-9840

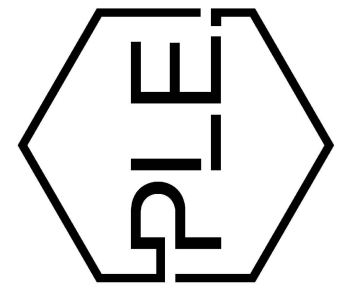

REVISION:

**THE GODDARD SCHOOL
OF BRYANT**
ALEXANDER, ARKANSAS

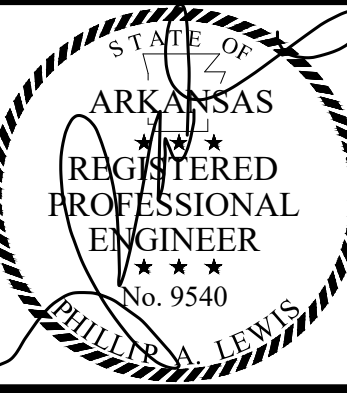
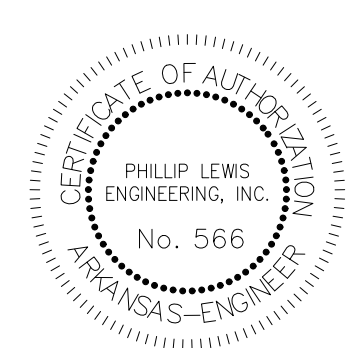

PROJECT NUMBER:

SHEET ISSUE DATE:
03-25-2026

PAGE TITLE:

**POST
DRAINAGE
PLAN**

SHEET NUMBER:

C1.8

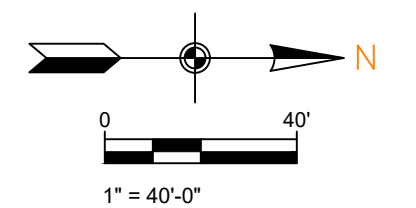



OVERALL DRAINAGE PLAN 1

SCALE 1" = 20'

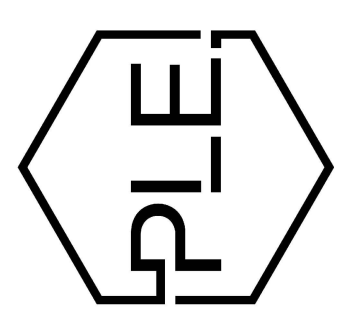
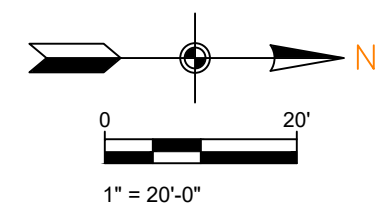

REVISION:

THE GODDARD SCHOOL
OF BRYANT
ALEXANDER, ARKANSAS

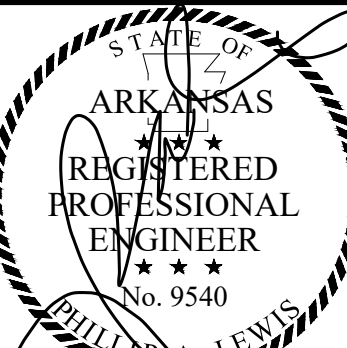
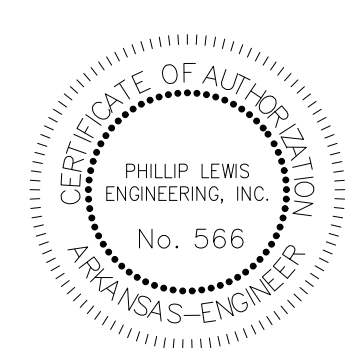

PROJECT NUMBER:

SHEET ISSUE DATE:
03-25-2026

PAGE TITLE:

OVERALL
DRAINAGE
PLAN 1

SHEET NUMBER:

C1.9



OVERALL DRAINAGE PLAN 2

SCALE 1" = 20'

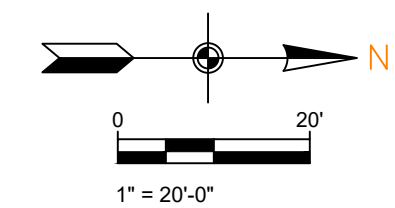

PHILLIP LEWIS ENGINEERING, INC.
Structural + Civil Consultants
23620 Interstate 30 | Bryant, Arkansas
PH: 501-350-9840

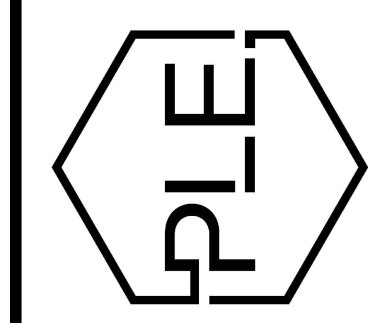

REVISION:

**THE GODDARD SCHOOL
OF BRYANT**
ALEXANDER, ARKANSAS

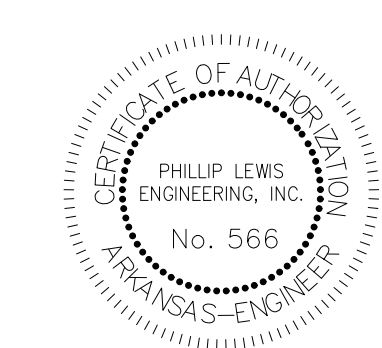

PROJECT NUMBER:

SHEET ISSUE DATE:
03-25-2026

PAGE TITLE:

**OVERALL
DRAINAGE
PLAN 2**

SHEET NUMBER:

C1.10

PRE DEVELOPMENT HYDROGRAPHS

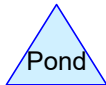
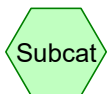
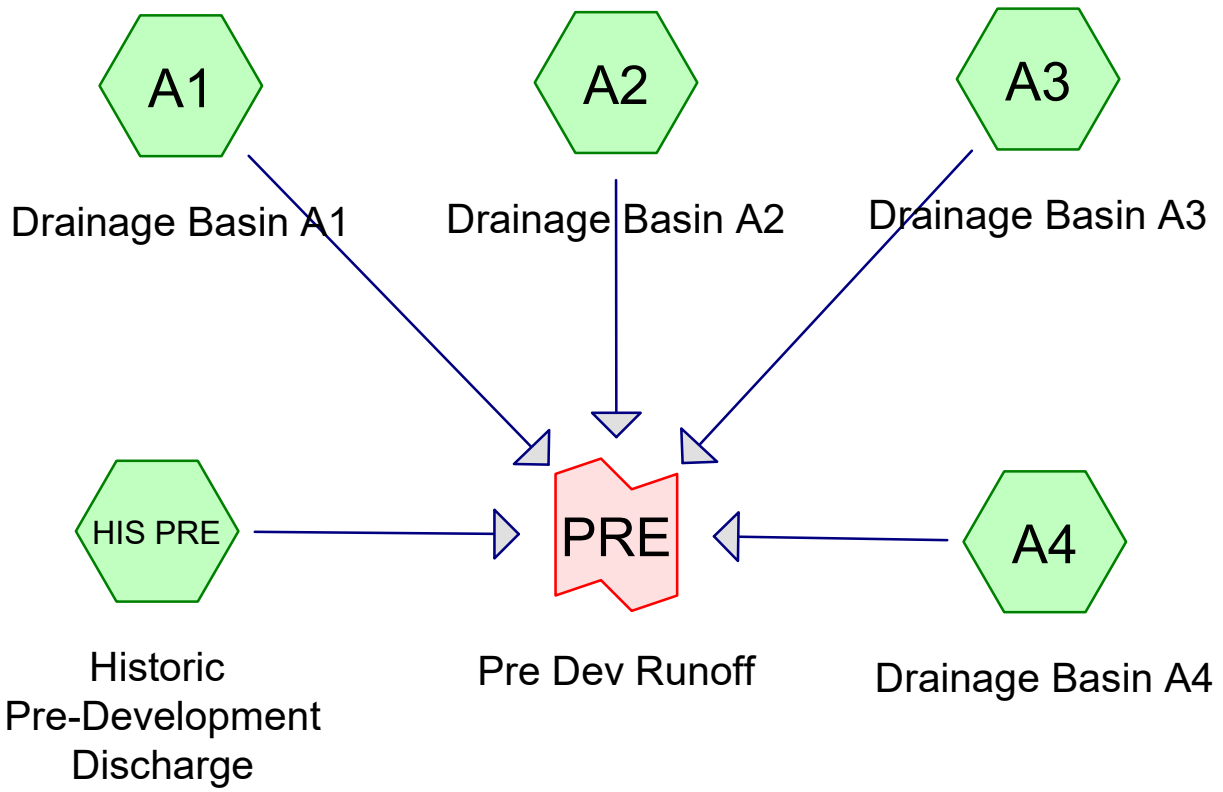

Goddard

Prepared by Phillip Lewis Engineering

HydroCAD® 10.20-5c s/n 12520 © 2023 HydroCAD Software Solutions LLC

AR - Little Rock 2-yr Duration=30 min, Inten=2.64 in/hr

Printed 3/25/2026

Summary for Subcatchment A1: Drainage Basin A1

Runoff = 0.85 cfs @ 0.21 hrs, Volume= 1,532 cf, Depth= 0.78"
 Routed to Link PRE : Pre Dev Runoff

Runoff by Rational method, Rise/Fall=1.0/1.0 xTc, Time Span= 0.00-3.00 hrs, dt= 0.01 hrs
 AR - Little Rock 2-yr Duration=30 min, Inten=2.64 in/hr

Area (sf)	C	Description
20,204	0.53	Undeveloped
3,399	0.92	Paving
23,603	0.59	Weighted Average
23,603		100.00% Pervious Area

Tc (min)	Length (feet)	Slope (ft/ft)	Velocity (ft/sec)	Capacity (cfs)	Description
6.1	48	0.0270	0.13		Sheet Flow, Sheet Flow Grass: Dense n= 0.240 P2= 4.19"
5.7	52	0.0380	0.15		Sheet Flow, Sheet Flow Grass: Dense n= 0.240 P2= 4.19"
0.3	37	0.0950	2.16		Shallow Concentrated Flow, Concentrated Flow Short Grass Pasture Kv= 7.0 fps
0.1	45	0.0860	5.95		Shallow Concentrated Flow, Concentrated Flow Paved Kv= 20.3 fps
0.1	17	0.0810	4.27		Shallow Concentrated Flow, Concentrated Flow Grassed Waterway Kv= 15.0 fps
0.0	16	0.0750	5.56		Shallow Concentrated Flow, Concentrated Flow Paved Kv= 20.3 fps
0.1	26	0.0710	5.41		Shallow Concentrated Flow, Concentrated Flow Paved Kv= 20.3 fps
0.1	32	0.0570	4.85		Shallow Concentrated Flow, Concentrated Flow Paved Kv= 20.3 fps
0.0	13	0.0470	4.40		Shallow Concentrated Flow, Concentrated Flow Paved Kv= 20.3 fps
12.5	286	Total			

Subcatchment A1: Drainage Basin A1

Hydrograph

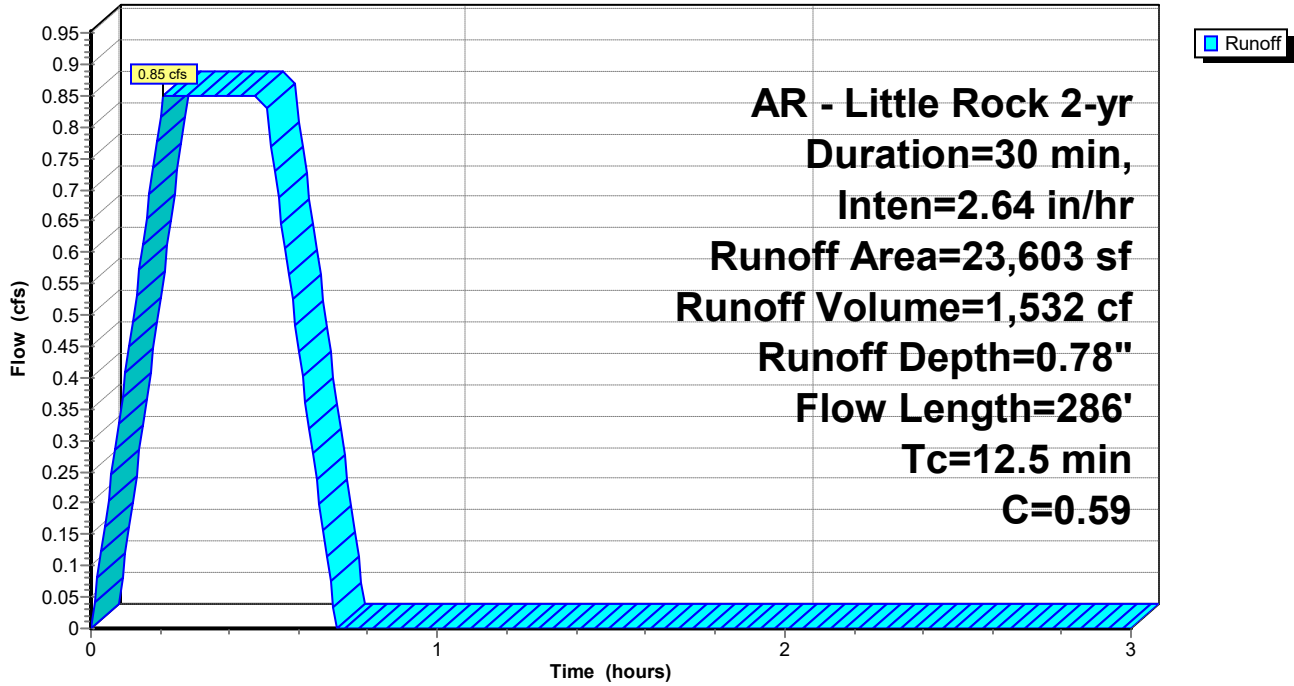

Summary for Subcatchment A2: Drainage Basin A2

Runoff = 2.05 cfs @ 0.25 hrs, Volume= 3,687 cf, Depth= 0.84"
 Routed to Link PRE : Pre Dev Runoff

Runoff by Rational method, Rise/Fall=1.0/1.0 xTc, Time Span= 0.00-3.00 hrs, dt= 0.01 hrs
 AR - Little Rock 2-yr Duration=30 min, Inten=2.64 in/hr

Area (sf)	C	Description
37,816	0.53	Undeveloped
14,559	0.92	Paving
52,375	0.64	Weighted Average
52,375		100.00% Pervious Area

Tc (min)	Length (feet)	Slope (ft/ft)	Velocity (ft/sec)	Capacity (cfs)	Description
4.6	36	0.0320	0.13		Sheet Flow, Sheet Flow Grass: Dense n= 0.240 P2= 4.19"
6.1	64	0.0480	0.17		Sheet Flow, Sheet Flow Grass: Dense n= 0.240 P2= 4.19"
0.9	76	0.0430	1.45		Shallow Concentrated Flow, Concentrated Flow Short Grass Pasture Kv= 7.0 fps
0.7	74	0.0710	1.87		Shallow Concentrated Flow, Concentrated Flow Short Grass Pasture Kv= 7.0 fps
0.2	36	0.1680	2.87		Shallow Concentrated Flow, Concentrated Flow Short Grass Pasture Kv= 7.0 fps
0.6	61	0.0070	1.70		Shallow Concentrated Flow, Concentrated Flow Paved Kv= 20.3 fps
0.2	38	0.0160	2.57		Shallow Concentrated Flow, Concentrated Flow Paved Kv= 20.3 fps
0.2	30	0.0190	2.80		Shallow Concentrated Flow, Concentrated Flow Paved Kv= 20.3 fps
1.3	216	0.0190	2.80		Shallow Concentrated Flow, Concentrated Flow Paved Kv= 20.3 fps
14.8	631	Total			

Subcatchment A2: Drainage Basin A2

Hydrograph

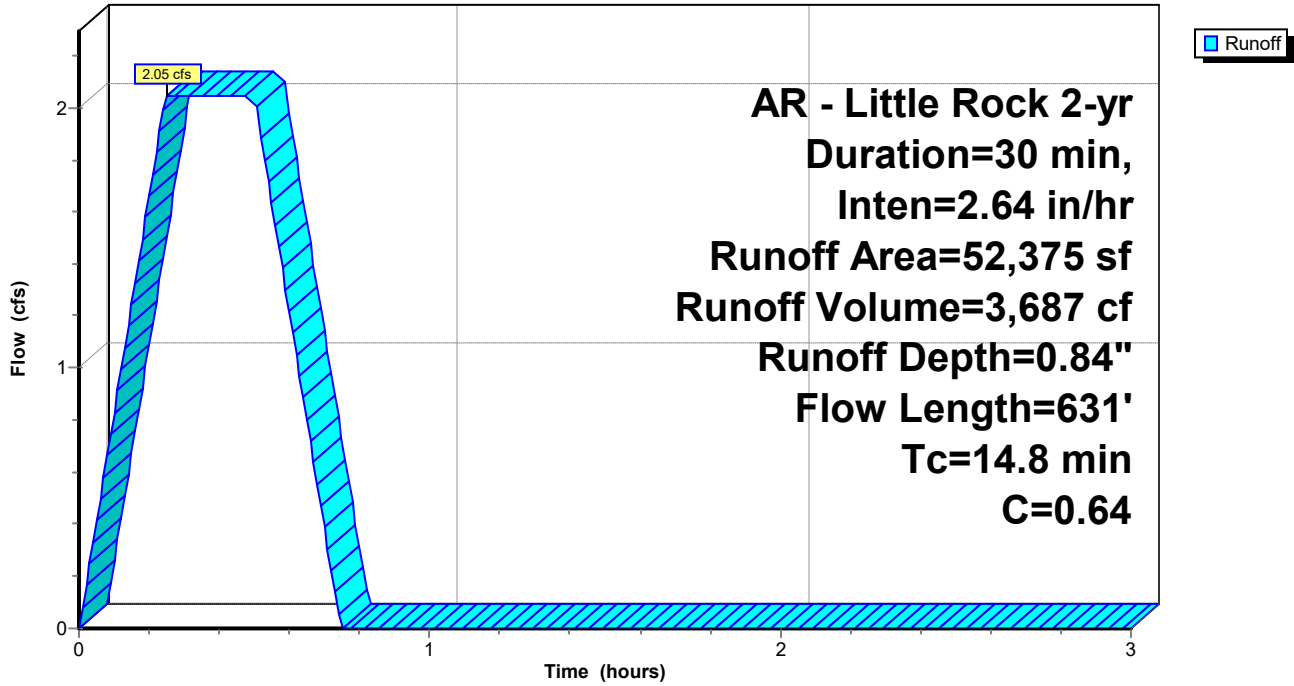

Goddard

Prepared by Phillip Lewis Engineering

HydroCAD® 10.20-5c s/n 12520 © 2023 HydroCAD Software Solutions LLC

AR - Little Rock 2-yr Duration=30 min, Inten=2.64 in/hr

Printed 3/25/2026

Summary for Subcatchment A3: Drainage Basin A3

Runoff = 0.45 cfs @ 0.19 hrs, Volume= 808 cf, Depth= 0.70"
 Routed to Link PRE : Pre Dev Runoff

Runoff by Rational method, Rise/Fall=1.0/1.0 xTc, Time Span= 0.00-3.00 hrs, dt= 0.01 hrs
 AR - Little Rock 2-yr Duration=30 min, Inten=2.64 in/hr

Area (sf)	C	Description
13,861	0.53	Undeveloped
0	0.92	Paving
13,861	0.53	Weighted Average
13,861		100.00% Pervious Area

Tc (min)	Length (feet)	Slope (ft/ft)	Velocity (ft/sec)	Capacity (cfs)	Description
8.4	100	0.0540	0.20		Sheet Flow, Sheet Flow Grass: Dense n= 0.240 P2= 4.19"
0.6	72	0.0790	1.97		Shallow Concentrated Flow, Concentrated Flow Short Grass Pasture Kv= 7.0 fps
0.2	21	0.0420	1.43		Shallow Concentrated Flow, Concentrated Flow Short Grass Pasture Kv= 7.0 fps
0.3	24	0.0400	1.40		Shallow Concentrated Flow, Concentrated Flow Short Grass Pasture Kv= 7.0 fps
1.4	102	0.0300	1.21		Shallow Concentrated Flow, Concentrated Flow Short Grass Pasture Kv= 7.0 fps
10.9	319	Total			

Subcatchment A3: Drainage Basin A3

Hydrograph

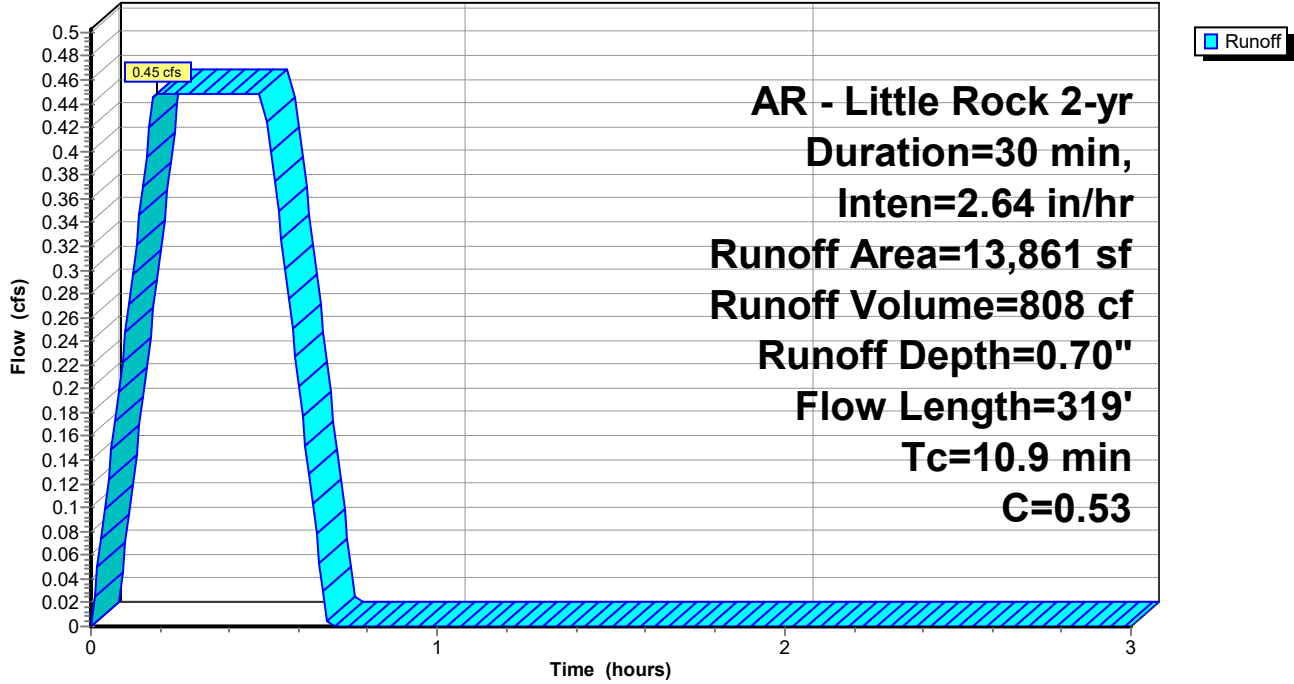

Goddard

Prepared by Phillip Lewis Engineering

HydroCAD® 10.20-5c s/n 12520 © 2023 HydroCAD Software Solutions LLC

AR - Little Rock 2-yr Duration=30 min, Inten=2.64 in/hr

Printed 3/25/2026

Summary for Subcatchment A4: Drainage Basin A4

Runoff = 2.92 cfs @ 0.19 hrs, Volume= 5,255 cf, Depth= 0.70"

Routed to Link PRE : Pre Dev Runoff

Runoff by Rational method, Rise/Fall=1.0/1.0 xTc, Time Span= 0.00-3.00 hrs, dt= 0.01 hrs

AR - Little Rock 2-yr Duration=30 min, Inten=2.64 in/hr

Area (sf)	C	Description
90,137	0.53	Undeveloped
0	0.92	Paving
90,137	0.53	Weighted Average
90,137		100.00% Pervious Area

Tc (min)	Length (feet)	Slope (ft/ft)	Velocity (ft/sec)	Capacity (cfs)	Description
7.1	100	0.0810	0.23		Sheet Flow, Sheet Flow
					Grass: Dense n= 0.240 P2= 4.19"
1.4	148	0.0680	1.83		Shallow Concentrated Flow, Concentrated Flow
					Short Grass Pasture Kv= 7.0 fps
0.2	26	0.1200	2.42		Shallow Concentrated Flow, Concentrated Flow
					Short Grass Pasture Kv= 7.0 fps
0.2	20	0.0410	1.42		Shallow Concentrated Flow, Concentrated Flow
					Short Grass Pasture Kv= 7.0 fps
0.6	51	0.0390	1.38		Shallow Concentrated Flow, Concentrated Flow
					Short Grass Pasture Kv= 7.0 fps
1.6	95	0.0210	1.01		Shallow Concentrated Flow, Concentrated Flow
					Short Grass Pasture Kv= 7.0 fps
11.1	440	Total			

Subcatchment A4: Drainage Basin A4

Hydrograph

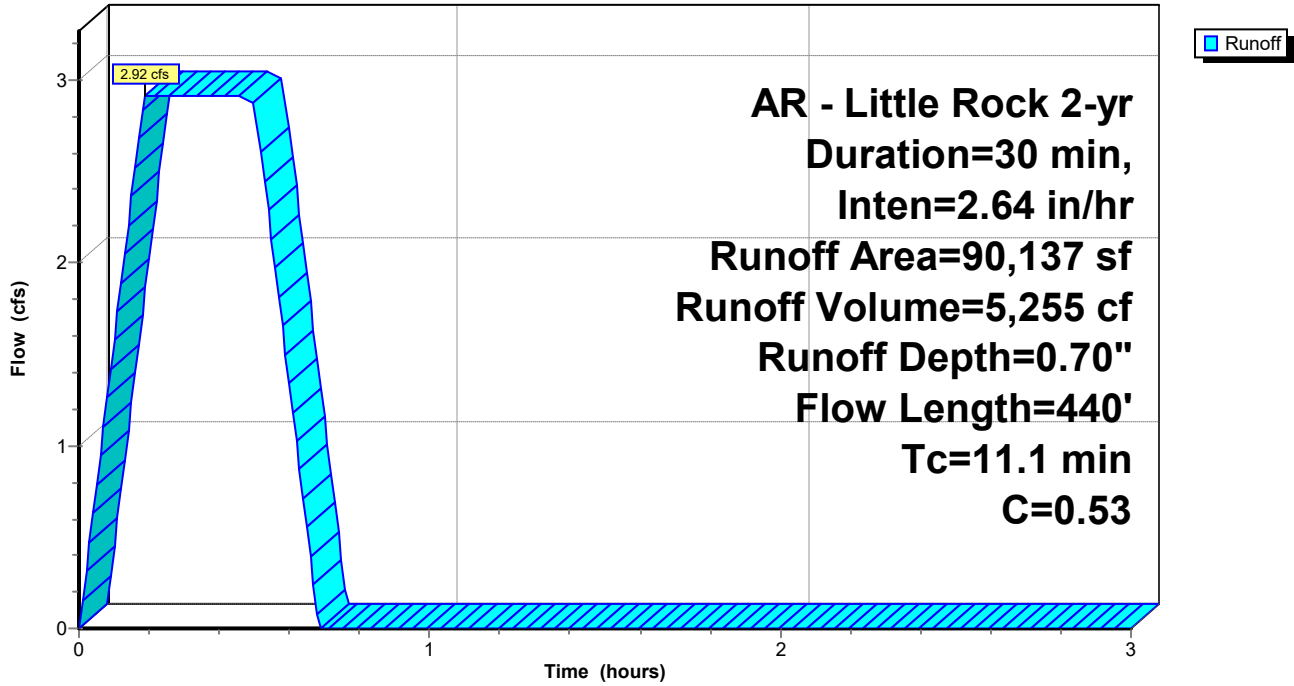

Summary for Subcatchment HIS PRE: Historic Pre-Development Discharge

Runoff = 10.00 cfs @ 0.47 hrs, Volume= 17,992 cf, Depth= 0.66"

Routed to Link PRE : Pre Dev Runoff

Runoff by Rational method, Rise/Fall=1.0/1.0 xTc, Time Span= 0.00-3.00 hrs, dt= 0.01 hrs
 AR - Little Rock 2-yr Duration=30 min, Inten=2.64 in/hr

Area (ac)	C	Description
7.510	0.50	Undeveloped
7.510		100.00% Pervious Area

Tc (min)	Length (feet)	Slope (ft/ft)	Velocity (ft/sec)	Capacity (cfs)	Description
28.0					Direct Entry,

Subcatchment HIS PRE: Historic Pre-Development Discharge

Hydrograph

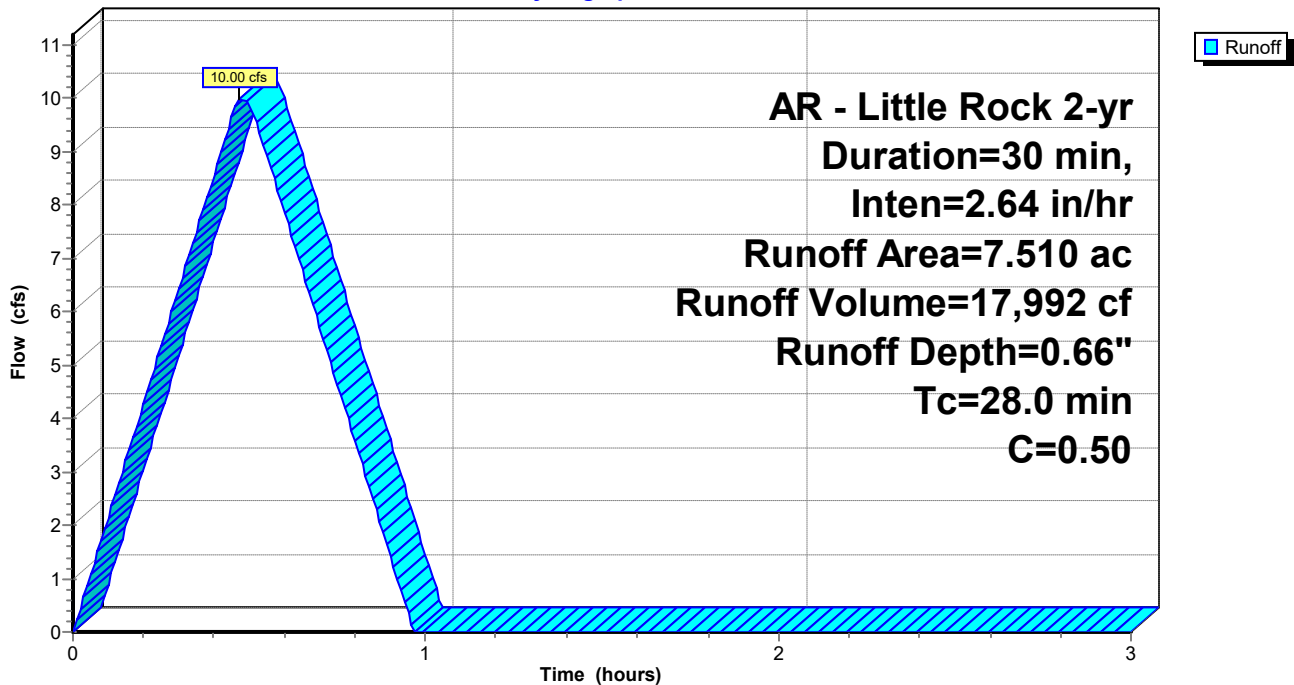

Summary for Link PRE: Pre Dev Runoff

Inflow Area = 507,112 sf, 0.00% Impervious, Inflow Depth = 0.69" for 2-yr event
Inflow = 16.26 cfs @ 0.47 hrs, Volume= 29,275 cf
Primary = 16.26 cfs @ 0.47 hrs, Volume= 29,275 cf, Atten= 0%, Lag= 0.0 min

Primary outflow = Inflow, Time Span= 0.00-3.00 hrs, dt= 0.01 hrs

Link PRE: Pre Dev Runoff

Hydrograph

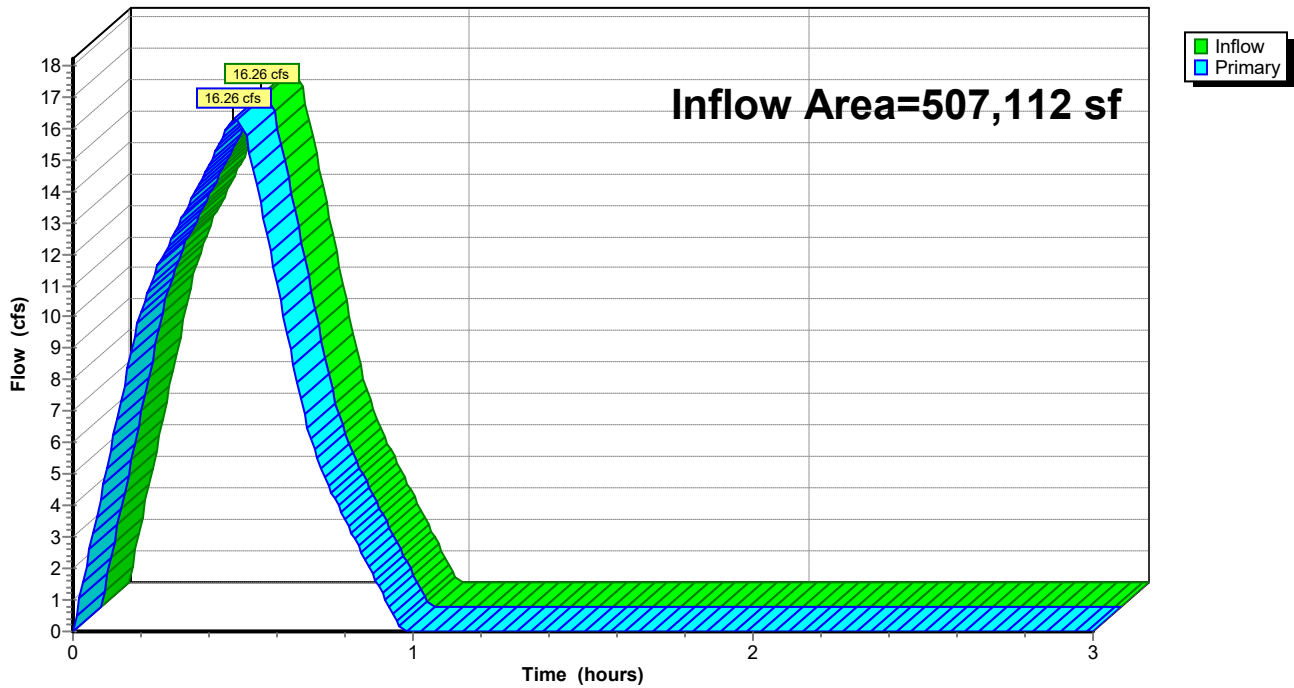

Goddard

Prepared by Phillip Lewis Engineering

HydroCAD® 10.20-5c s/n 12520 © 2023 HydroCAD Software Solutions LLC

AR - Little Rock 5-yr Duration=30 min, Inten=3.16 in/hr

Printed 3/25/2026

Summary for Subcatchment A1: Drainage Basin A1

Runoff = 1.02 cfs @ 0.21 hrs, Volume= 1,834 cf, Depth= 0.93"

Routed to Link PRE : Pre Dev Runoff

Runoff by Rational method, Rise/Fall=1.0/1.0 xTc, Time Span= 0.00-3.00 hrs, dt= 0.01 hrs

AR - Little Rock 5-yr Duration=30 min, Inten=3.16 in/hr

Area (sf)	C	Description
20,204	0.53	Undeveloped
3,399	0.92	Paving
23,603	0.59	Weighted Average
23,603		100.00% Pervious Area

Tc (min)	Length (feet)	Slope (ft/ft)	Velocity (ft/sec)	Capacity (cfs)	Description
6.1	48	0.0270	0.13		Sheet Flow, Sheet Flow
					Grass: Dense n= 0.240 P2= 4.19"
5.7	52	0.0380	0.15		Sheet Flow, Sheet Flow
					Grass: Dense n= 0.240 P2= 4.19"
0.3	37	0.0950	2.16		Shallow Concentrated Flow, Concentrated Flow
					Short Grass Pasture Kv= 7.0 fps
0.1	45	0.0860	5.95		Shallow Concentrated Flow, Concentrated Flow
					Paved Kv= 20.3 fps
0.1	17	0.0810	4.27		Shallow Concentrated Flow, Concentrated Flow
					Grassed Waterway Kv= 15.0 fps
0.0	16	0.0750	5.56		Shallow Concentrated Flow, Concentrated Flow
					Paved Kv= 20.3 fps
0.1	26	0.0710	5.41		Shallow Concentrated Flow, Concentrated Flow
					Paved Kv= 20.3 fps
0.1	32	0.0570	4.85		Shallow Concentrated Flow, Concentrated Flow
					Paved Kv= 20.3 fps
0.0	13	0.0470	4.40		Shallow Concentrated Flow, Concentrated Flow
					Paved Kv= 20.3 fps
12.5	286	Total			

Subcatchment A1: Drainage Basin A1

Hydrograph

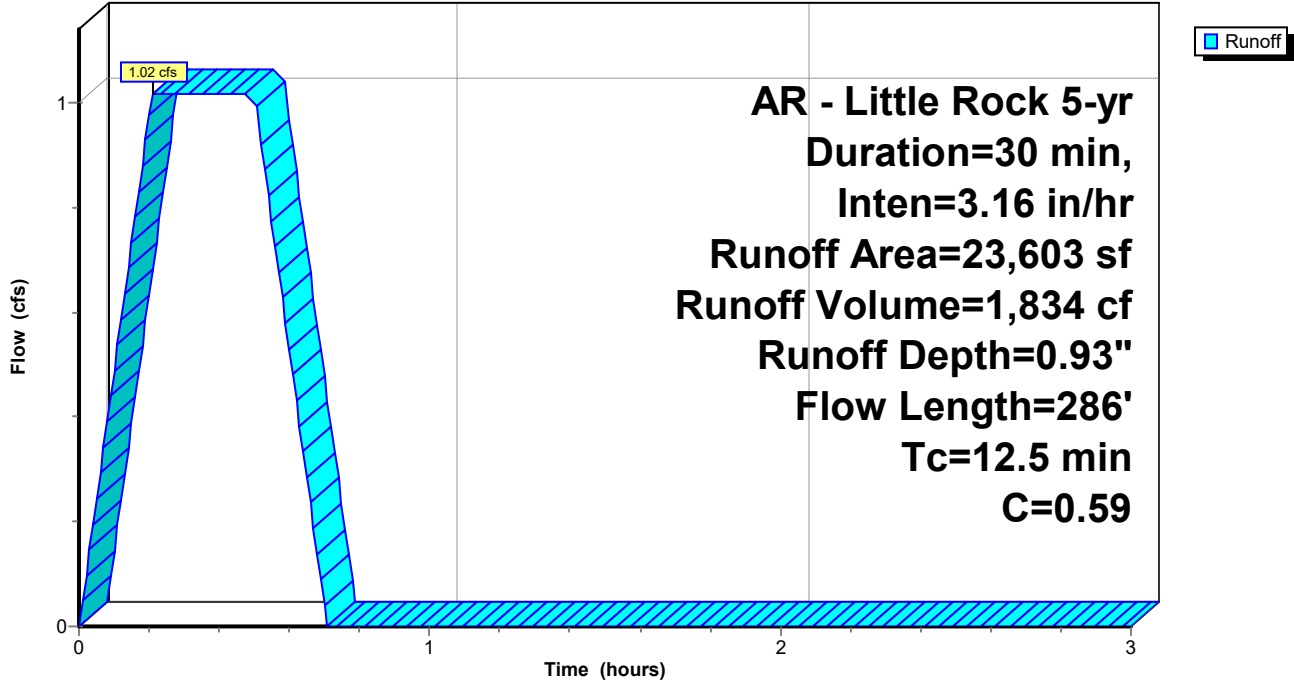

Goddard

Prepared by Phillip Lewis Engineering

HydroCAD® 10.20-5c s/n 12520 © 2023 HydroCAD Software Solutions LLC

AR - Little Rock 5-yr Duration=30 min, Inten=3.16 in/hr

Printed 3/25/2026

Summary for Subcatchment A2: Drainage Basin A2

Runoff = 2.45 cfs @ 0.25 hrs, Volume= 4,413 cf, Depth= 1.01"

Routed to Link PRE : Pre Dev Runoff

Runoff by Rational method, Rise/Fall=1.0/1.0 xTc, Time Span= 0.00-3.00 hrs, dt= 0.01 hrs

AR - Little Rock 5-yr Duration=30 min, Inten=3.16 in/hr

Area (sf)	C	Description
37,816	0.53	Undeveloped
14,559	0.92	Paving
52,375	0.64	Weighted Average
52,375		100.00% Pervious Area

Tc (min)	Length (feet)	Slope (ft/ft)	Velocity (ft/sec)	Capacity (cfs)	Description
4.6	36	0.0320	0.13		Sheet Flow, Sheet Flow
					Grass: Dense n= 0.240 P2= 4.19"
6.1	64	0.0480	0.17		Sheet Flow, Sheet Flow
					Grass: Dense n= 0.240 P2= 4.19"
0.9	76	0.0430	1.45		Shallow Concentrated Flow, Concentrated Flow
					Short Grass Pasture Kv= 7.0 fps
0.7	74	0.0710	1.87		Shallow Concentrated Flow, Concentrated Flow
					Short Grass Pasture Kv= 7.0 fps
0.2	36	0.1680	2.87		Shallow Concentrated Flow, Concentrated Flow
					Short Grass Pasture Kv= 7.0 fps
0.6	61	0.0070	1.70		Shallow Concentrated Flow, Concentrated Flow
					Paved Kv= 20.3 fps
0.2	38	0.0160	2.57		Shallow Concentrated Flow, Concentrated Flow
					Paved Kv= 20.3 fps
0.2	30	0.0190	2.80		Shallow Concentrated Flow, Concentrated Flow
					Paved Kv= 20.3 fps
1.3	216	0.0190	2.80		Shallow Concentrated Flow, Concentrated Flow
					Paved Kv= 20.3 fps
14.8	631	Total			

Subcatchment A2: Drainage Basin A2

Hydrograph

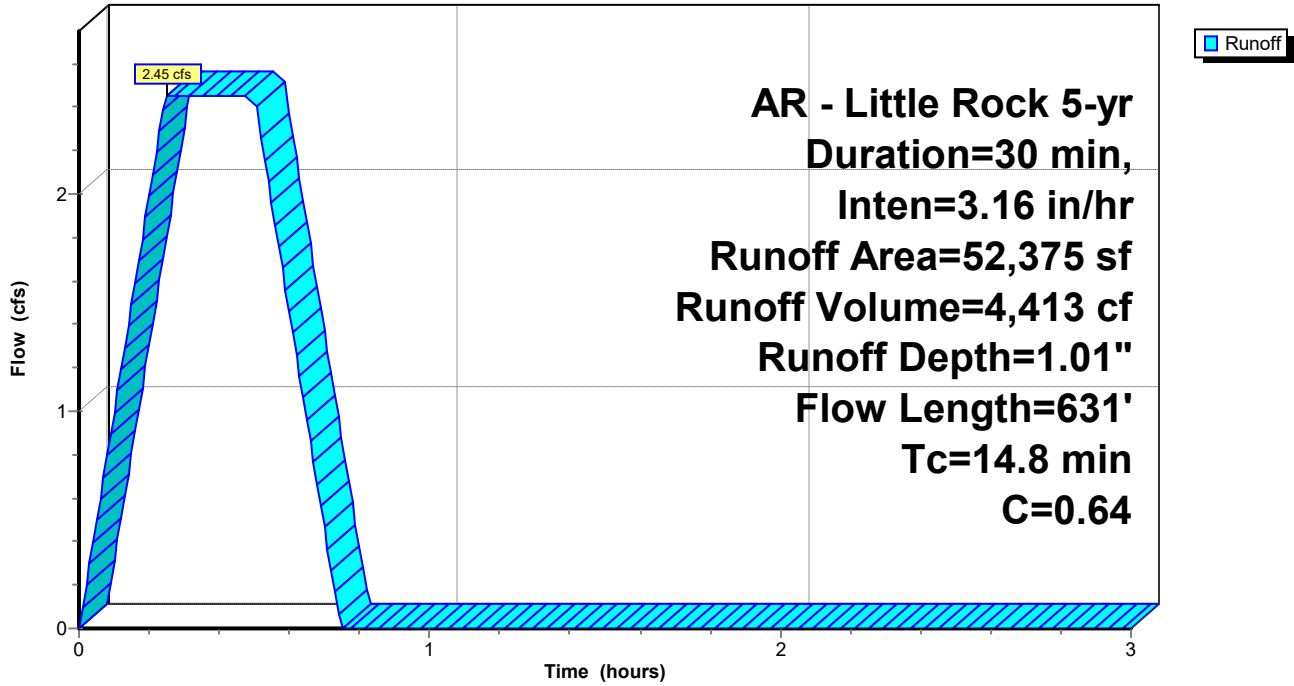

Goddard

Prepared by Phillip Lewis Engineering

HydroCAD® 10.20-5c s/n 12520 © 2023 HydroCAD Software Solutions LLC

AR - Little Rock 5-yr Duration=30 min, Inten=3.16 in/hr

Printed 3/25/2026

Summary for Subcatchment A3: Drainage Basin A3

Runoff = 0.54 cfs @ 0.19 hrs, Volume= 967 cf, Depth= 0.84"

Routed to Link PRE : Pre Dev Runoff

Runoff by Rational method, Rise/Fall=1.0/1.0 xTc, Time Span= 0.00-3.00 hrs, dt= 0.01 hrs

AR - Little Rock 5-yr Duration=30 min, Inten=3.16 in/hr

Area (sf)	C	Description
13,861	0.53	Undeveloped
0	0.92	Paving
13,861	0.53	Weighted Average
13,861		100.00% Pervious Area

Tc (min)	Length (feet)	Slope (ft/ft)	Velocity (ft/sec)	Capacity (cfs)	Description
8.4	100	0.0540	0.20		Sheet Flow, Sheet Flow Grass: Dense n= 0.240 P2= 4.19"
0.6	72	0.0790	1.97		Shallow Concentrated Flow, Concentrated Flow Short Grass Pasture Kv= 7.0 fps
0.2	21	0.0420	1.43		Shallow Concentrated Flow, Concentrated Flow Short Grass Pasture Kv= 7.0 fps
0.3	24	0.0400	1.40		Shallow Concentrated Flow, Concentrated Flow Short Grass Pasture Kv= 7.0 fps
1.4	102	0.0300	1.21		Shallow Concentrated Flow, Concentrated Flow Short Grass Pasture Kv= 7.0 fps
10.9	319	Total			

Subcatchment A3: Drainage Basin A3

Hydrograph

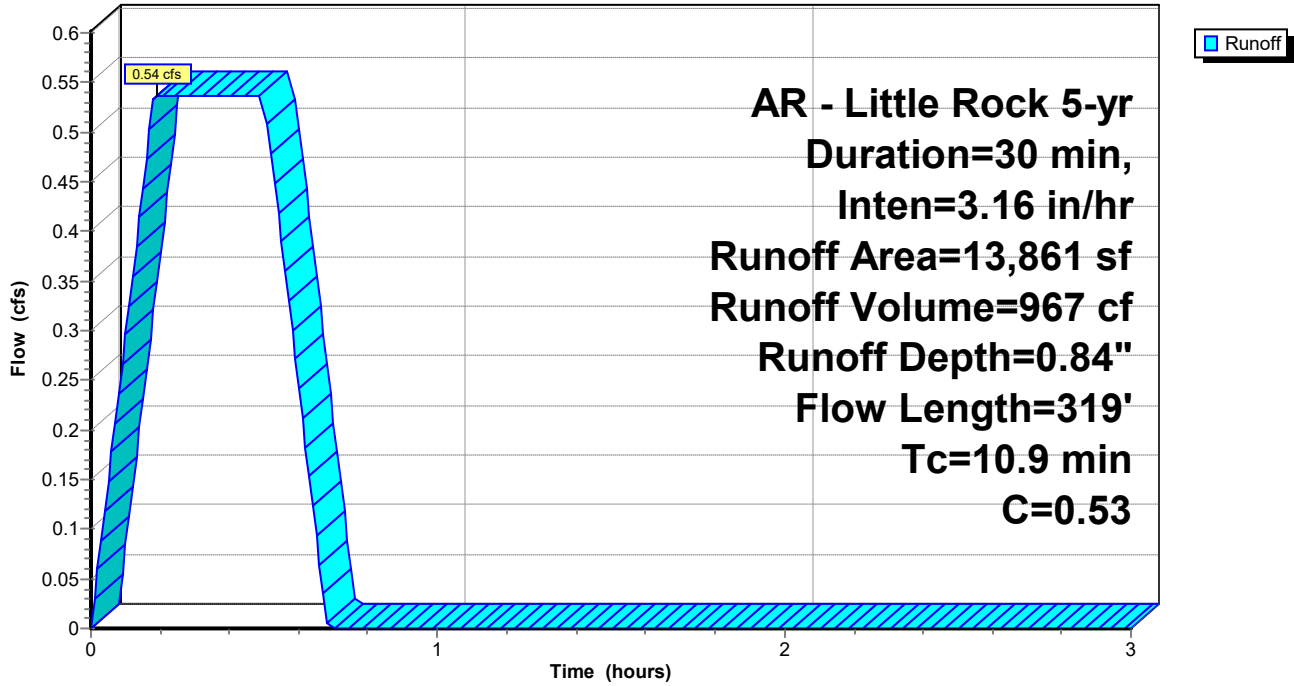

Goddard

Prepared by Phillip Lewis Engineering

HydroCAD® 10.20-5c s/n 12520 © 2023 HydroCAD Software Solutions LLC

AR - Little Rock 5-yr Duration=30 min, Inten=3.16 in/hr

Printed 3/25/2026

Summary for Subcatchment A4: Drainage Basin A4

Runoff = 3.49 cfs @ 0.19 hrs, Volume= 6,290 cf, Depth= 0.84"
 Routed to Link PRE : Pre Dev Runoff

Runoff by Rational method, Rise/Fall=1.0/1.0 xTc, Time Span= 0.00-3.00 hrs, dt= 0.01 hrs
 AR - Little Rock 5-yr Duration=30 min, Inten=3.16 in/hr

Area (sf)	C	Description
90,137	0.53	Undeveloped
0	0.92	Paving
90,137	0.53	Weighted Average
90,137		100.00% Pervious Area

Tc (min)	Length (feet)	Slope (ft/ft)	Velocity (ft/sec)	Capacity (cfs)	Description
7.1	100	0.0810	0.23		Sheet Flow, Sheet Flow Grass: Dense n= 0.240 P2= 4.19"
1.4	148	0.0680	1.83		Shallow Concentrated Flow, Concentrated Flow Short Grass Pasture Kv= 7.0 fps
0.2	26	0.1200	2.42		Shallow Concentrated Flow, Concentrated Flow Short Grass Pasture Kv= 7.0 fps
0.2	20	0.0410	1.42		Shallow Concentrated Flow, Concentrated Flow Short Grass Pasture Kv= 7.0 fps
0.6	51	0.0390	1.38		Shallow Concentrated Flow, Concentrated Flow Short Grass Pasture Kv= 7.0 fps
1.6	95	0.0210	1.01		Shallow Concentrated Flow, Concentrated Flow Short Grass Pasture Kv= 7.0 fps
11.1	440	Total			

Subcatchment A4: Drainage Basin A4

Hydrograph

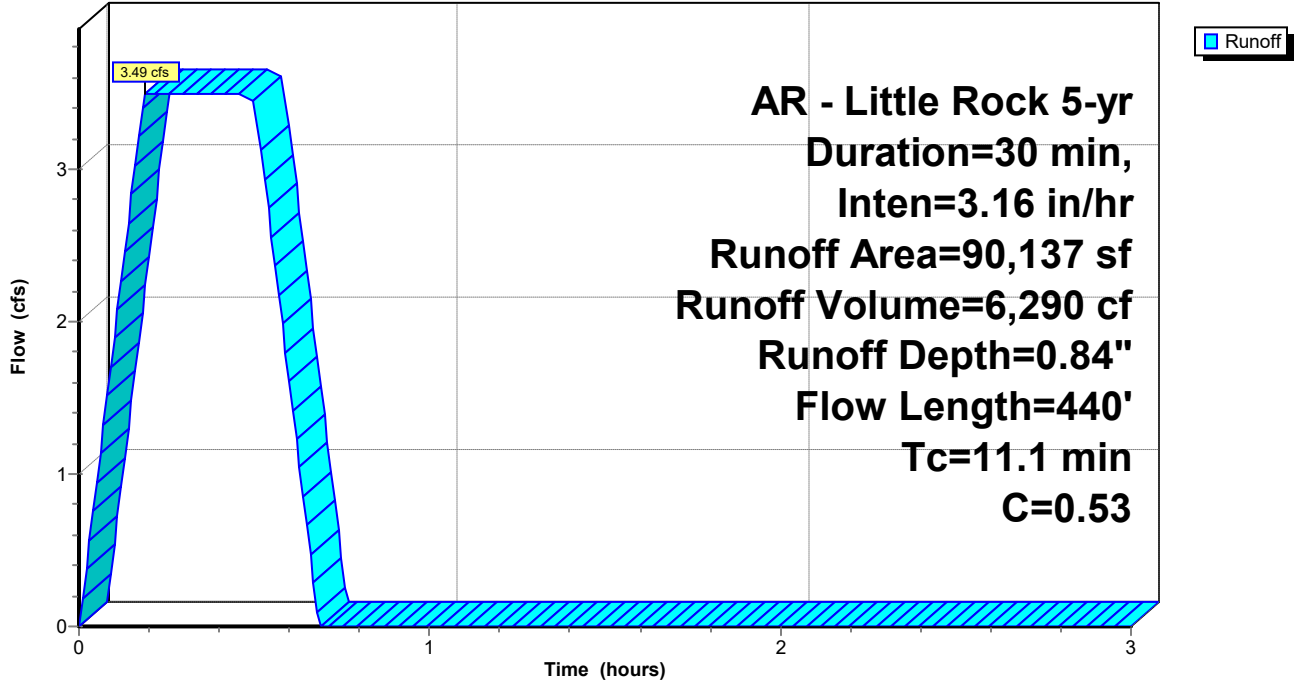

Summary for Subcatchment HIS PRE: Historic Pre-Development Discharge

Runoff = 11.96 cfs @ 0.47 hrs, Volume= 21,536 cf, Depth= 0.79"

Routed to Link PRE : Pre Dev Runoff

Runoff by Rational method, Rise/Fall=1.0/1.0 xTc, Time Span= 0.00-3.00 hrs, dt= 0.01 hrs
 AR - Little Rock 5-yr Duration=30 min, Inten=3.16 in/hr

Area (ac)	C	Description
7.510	0.50	Undeveloped
7.510		100.00% Pervious Area

Tc (min)	Length (feet)	Slope (ft/ft)	Velocity (ft/sec)	Capacity (cfs)	Description
28.0					Direct Entry,

Subcatchment HIS PRE: Historic Pre-Development Discharge

Hydrograph

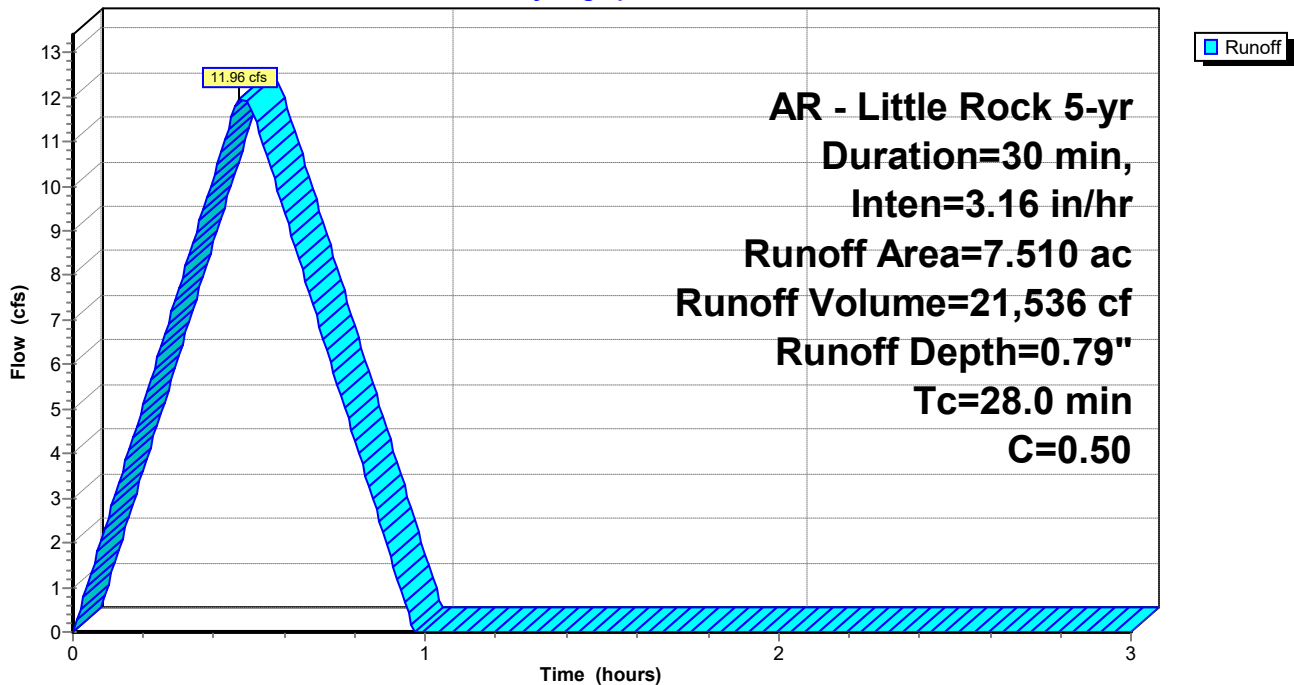

Summary for Link PRE: Pre Dev Runoff

Inflow Area = 507,112 sf, 0.00% Impervious, Inflow Depth = 0.83" for 5-yr event
Inflow = 19.47 cfs @ 0.47 hrs, Volume= 35,041 cf
Primary = 19.47 cfs @ 0.47 hrs, Volume= 35,041 cf, Atten= 0%, Lag= 0.0 min

Primary outflow = Inflow, Time Span= 0.00-3.00 hrs, dt= 0.01 hrs

Link PRE: Pre Dev Runoff

Hydrograph

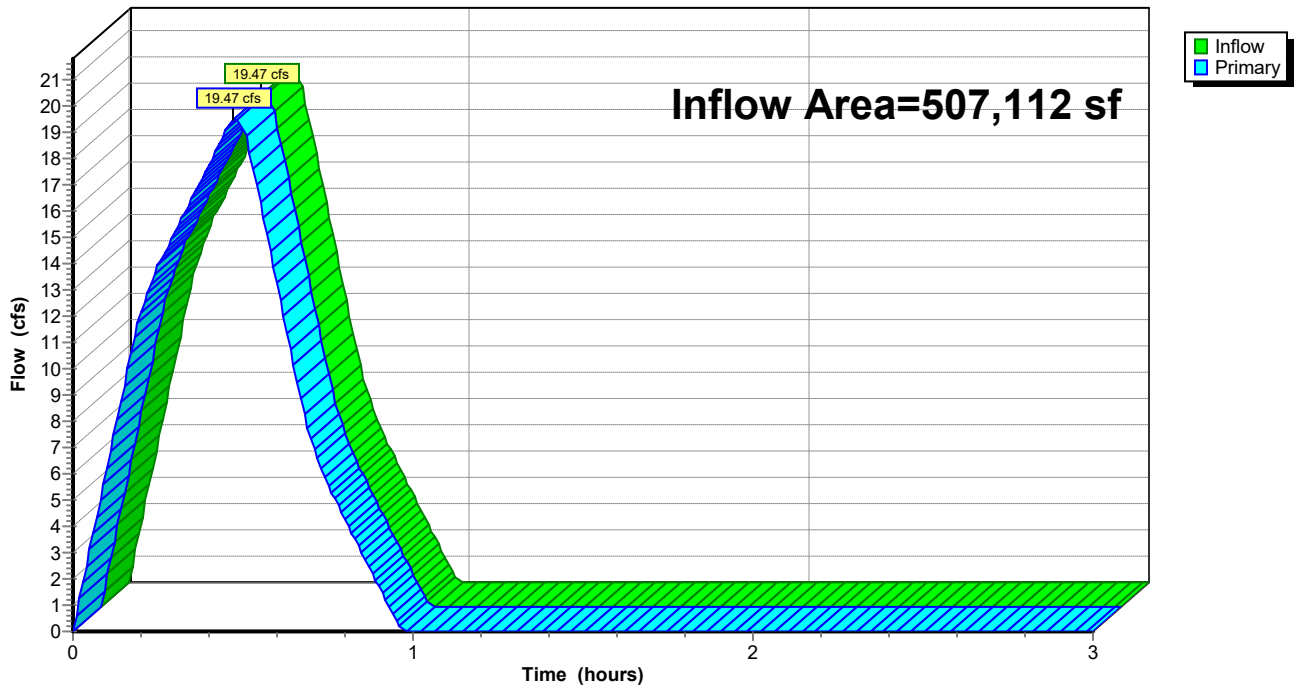

Goddard

Prepared by Phillip Lewis Engineering

HydroCAD® 10.20-5c s/n 12520 © 2023 HydroCAD Software Solutions LLC

AR - Little Rock 10-yr Duration=30 min, Inten=3.56 in/hr

Printed 3/25/2026

Summary for Subcatchment A1: Drainage Basin A1

Runoff = 1.15 cfs @ 0.21 hrs, Volume= 2,066 cf, Depth= 1.05"
 Routed to Link PRE : Pre Dev Runoff

Runoff by Rational method, Rise/Fall=1.0/1.0 xTc, Time Span= 0.00-3.00 hrs, dt= 0.01 hrs
 AR - Little Rock 10-yr Duration=30 min, Inten=3.56 in/hr

Area (sf)	C	Description
20,204	0.53	Undeveloped
3,399	0.92	Paving
23,603	0.59	Weighted Average
23,603		100.00% Pervious Area

Tc (min)	Length (feet)	Slope (ft/ft)	Velocity (ft/sec)	Capacity (cfs)	Description
6.1	48	0.0270	0.13		Sheet Flow, Sheet Flow Grass: Dense n= 0.240 P2= 4.19"
5.7	52	0.0380	0.15		Sheet Flow, Sheet Flow Grass: Dense n= 0.240 P2= 4.19"
0.3	37	0.0950	2.16		Shallow Concentrated Flow, Concentrated Flow Short Grass Pasture Kv= 7.0 fps
0.1	45	0.0860	5.95		Shallow Concentrated Flow, Concentrated Flow Paved Kv= 20.3 fps
0.1	17	0.0810	4.27		Shallow Concentrated Flow, Concentrated Flow Grassed Waterway Kv= 15.0 fps
0.0	16	0.0750	5.56		Shallow Concentrated Flow, Concentrated Flow Paved Kv= 20.3 fps
0.1	26	0.0710	5.41		Shallow Concentrated Flow, Concentrated Flow Paved Kv= 20.3 fps
0.1	32	0.0570	4.85		Shallow Concentrated Flow, Concentrated Flow Paved Kv= 20.3 fps
0.0	13	0.0470	4.40		Shallow Concentrated Flow, Concentrated Flow Paved Kv= 20.3 fps
12.5	286	Total			

Subcatchment A1: Drainage Basin A1

Hydrograph

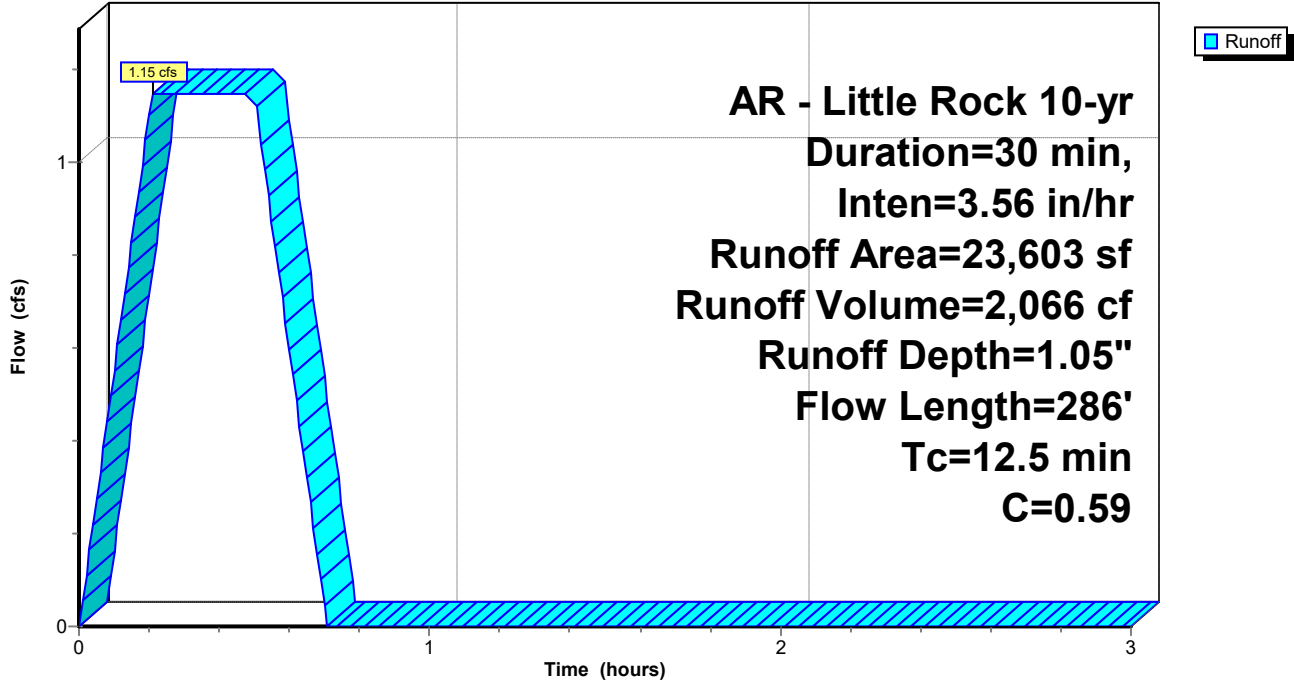

Goddard

Prepared by Phillip Lewis Engineering

HydroCAD® 10.20-5c s/n 12520 © 2023 HydroCAD Software Solutions LLC

AR - Little Rock 10-yr Duration=30 min, Inten=3.56 in/hr

Printed 3/25/2026

Summary for Subcatchment A2: Drainage Basin A2

Runoff = 2.76 cfs @ 0.25 hrs, Volume= 4,972 cf, Depth= 1.14"
 Routed to Link PRE : Pre Dev Runoff

Runoff by Rational method, Rise/Fall=1.0/1.0 xTc, Time Span= 0.00-3.00 hrs, dt= 0.01 hrs
 AR - Little Rock 10-yr Duration=30 min, Inten=3.56 in/hr

Area (sf)	C	Description
37,816	0.53	Undeveloped
14,559	0.92	Paving
52,375	0.64	Weighted Average
52,375		100.00% Pervious Area

Tc (min)	Length (feet)	Slope (ft/ft)	Velocity (ft/sec)	Capacity (cfs)	Description
4.6	36	0.0320	0.13		Sheet Flow, Sheet Flow
					Grass: Dense n= 0.240 P2= 4.19"
6.1	64	0.0480	0.17		Sheet Flow, Sheet Flow
					Grass: Dense n= 0.240 P2= 4.19"
0.9	76	0.0430	1.45		Shallow Concentrated Flow, Concentrated Flow
					Short Grass Pasture Kv= 7.0 fps
0.7	74	0.0710	1.87		Shallow Concentrated Flow, Concentrated Flow
					Short Grass Pasture Kv= 7.0 fps
0.2	36	0.1680	2.87		Shallow Concentrated Flow, Concentrated Flow
					Short Grass Pasture Kv= 7.0 fps
0.6	61	0.0070	1.70		Shallow Concentrated Flow, Concentrated Flow
					Paved Kv= 20.3 fps
0.2	38	0.0160	2.57		Shallow Concentrated Flow, Concentrated Flow
					Paved Kv= 20.3 fps
0.2	30	0.0190	2.80		Shallow Concentrated Flow, Concentrated Flow
					Paved Kv= 20.3 fps
1.3	216	0.0190	2.80		Shallow Concentrated Flow, Concentrated Flow
					Paved Kv= 20.3 fps
14.8	631	Total			

Subcatchment A2: Drainage Basin A2

Hydrograph

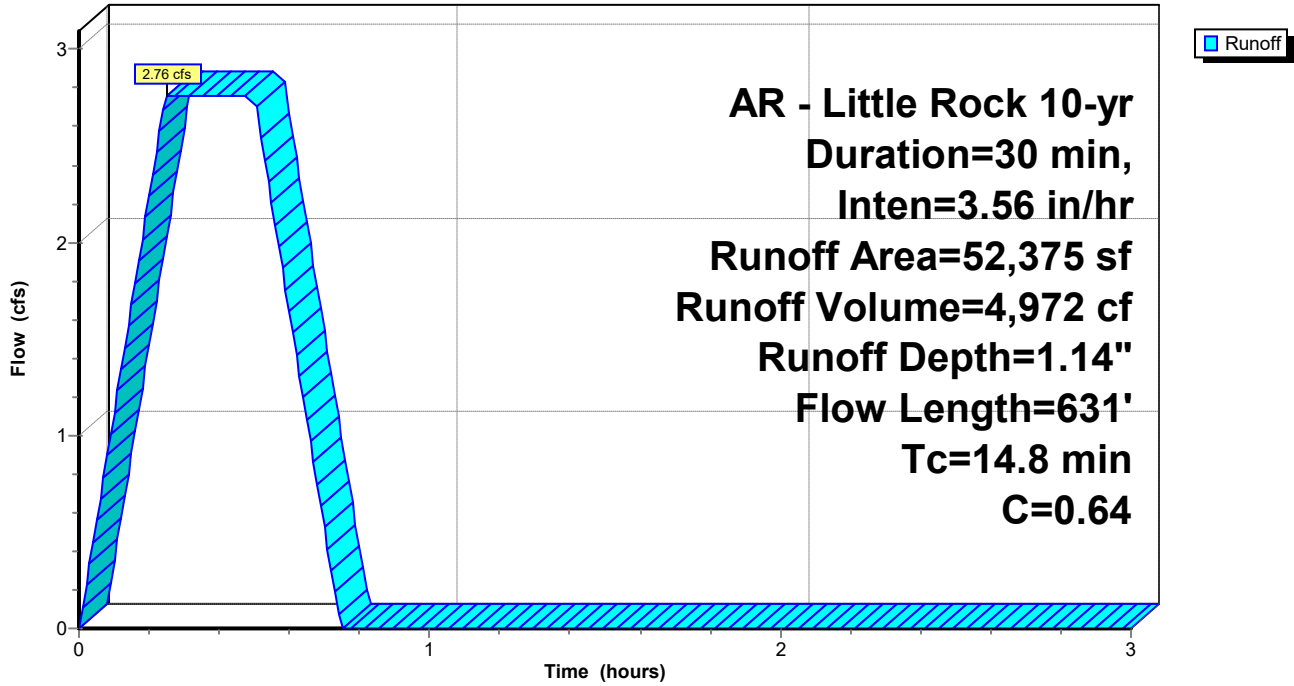

Goddard

Prepared by Phillip Lewis Engineering

HydroCAD® 10.20-5c s/n 12520 © 2023 HydroCAD Software Solutions LLC

AR - Little Rock 10-yr Duration=30 min, Inten=3.56 in/hr

Printed 3/25/2026

Summary for Subcatchment A3: Drainage Basin A3

Runoff = 0.61 cfs @ 0.19 hrs, Volume= 1,090 cf, Depth= 0.94"

Routed to Link PRE : Pre Dev Runoff

Runoff by Rational method, Rise/Fall=1.0/1.0 xTc, Time Span= 0.00-3.00 hrs, dt= 0.01 hrs

AR - Little Rock 10-yr Duration=30 min, Inten=3.56 in/hr

Area (sf)	C	Description
13,861	0.53	Undeveloped
0	0.92	Paving
13,861	0.53	Weighted Average
13,861		100.00% Pervious Area

Tc (min)	Length (feet)	Slope (ft/ft)	Velocity (ft/sec)	Capacity (cfs)	Description
8.4	100	0.0540	0.20		Sheet Flow, Sheet Flow Grass: Dense n= 0.240 P2= 4.19"
0.6	72	0.0790	1.97		Shallow Concentrated Flow, Concentrated Flow Short Grass Pasture Kv= 7.0 fps
0.2	21	0.0420	1.43		Shallow Concentrated Flow, Concentrated Flow Short Grass Pasture Kv= 7.0 fps
0.3	24	0.0400	1.40		Shallow Concentrated Flow, Concentrated Flow Short Grass Pasture Kv= 7.0 fps
1.4	102	0.0300	1.21		Shallow Concentrated Flow, Concentrated Flow Short Grass Pasture Kv= 7.0 fps
10.9	319	Total			

Subcatchment A3: Drainage Basin A3

Hydrograph

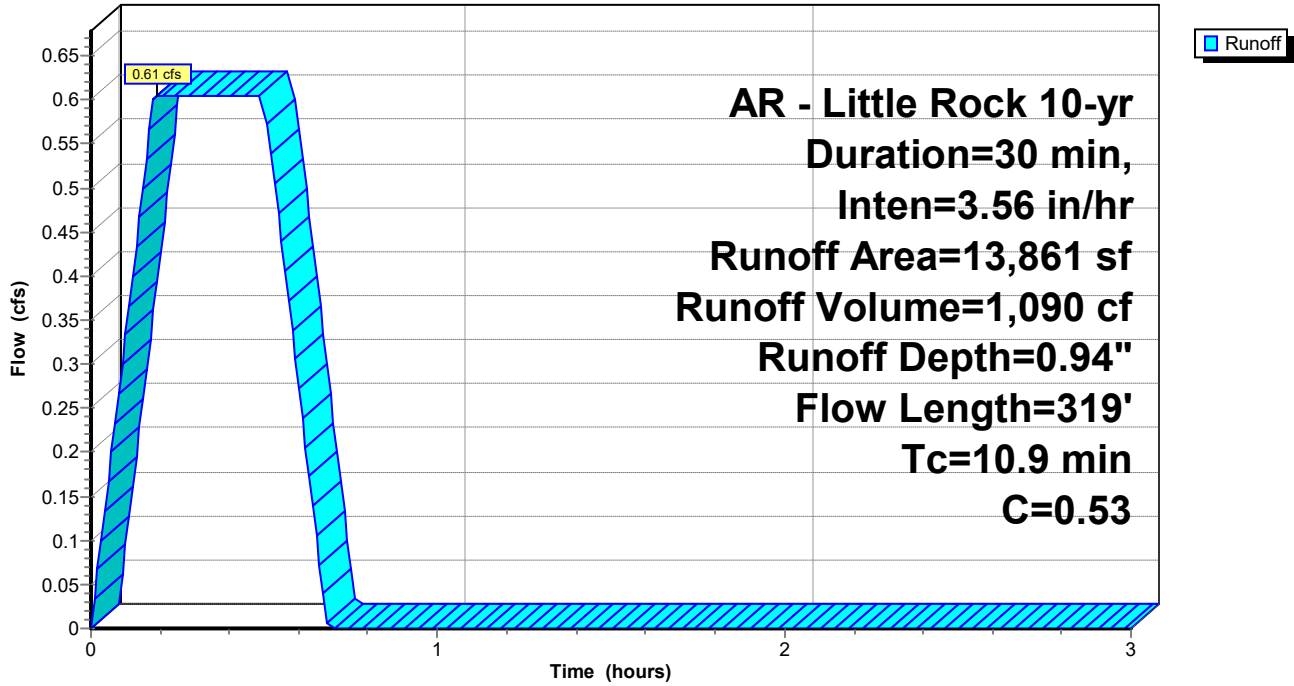

Goddard

Prepared by Phillip Lewis Engineering

HydroCAD® 10.20-5c s/n 12520 © 2023 HydroCAD Software Solutions LLC

AR - Little Rock 10-yr Duration=30 min, Inten=3.56 in/hr

Printed 3/25/2026

Summary for Subcatchment A4: Drainage Basin A4

Runoff = 3.94 cfs @ 0.19 hrs, Volume= 7,086 cf, Depth= 0.94"
 Routed to Link PRE : Pre Dev Runoff

Runoff by Rational method, Rise/Fall=1.0/1.0 xTc, Time Span= 0.00-3.00 hrs, dt= 0.01 hrs
 AR - Little Rock 10-yr Duration=30 min, Inten=3.56 in/hr

Area (sf)	C	Description
90,137	0.53	Undeveloped
0	0.92	Paving
90,137	0.53	Weighted Average
90,137		100.00% Pervious Area

Tc (min)	Length (feet)	Slope (ft/ft)	Velocity (ft/sec)	Capacity (cfs)	Description
7.1	100	0.0810	0.23		Sheet Flow, Sheet Flow
					Grass: Dense n= 0.240 P2= 4.19"
1.4	148	0.0680	1.83		Shallow Concentrated Flow, Concentrated Flow
					Short Grass Pasture Kv= 7.0 fps
0.2	26	0.1200	2.42		Shallow Concentrated Flow, Concentrated Flow
					Short Grass Pasture Kv= 7.0 fps
0.2	20	0.0410	1.42		Shallow Concentrated Flow, Concentrated Flow
					Short Grass Pasture Kv= 7.0 fps
0.6	51	0.0390	1.38		Shallow Concentrated Flow, Concentrated Flow
					Short Grass Pasture Kv= 7.0 fps
1.6	95	0.0210	1.01		Shallow Concentrated Flow, Concentrated Flow
					Short Grass Pasture Kv= 7.0 fps
11.1	440	Total			

Subcatchment A4: Drainage Basin A4

Hydrograph

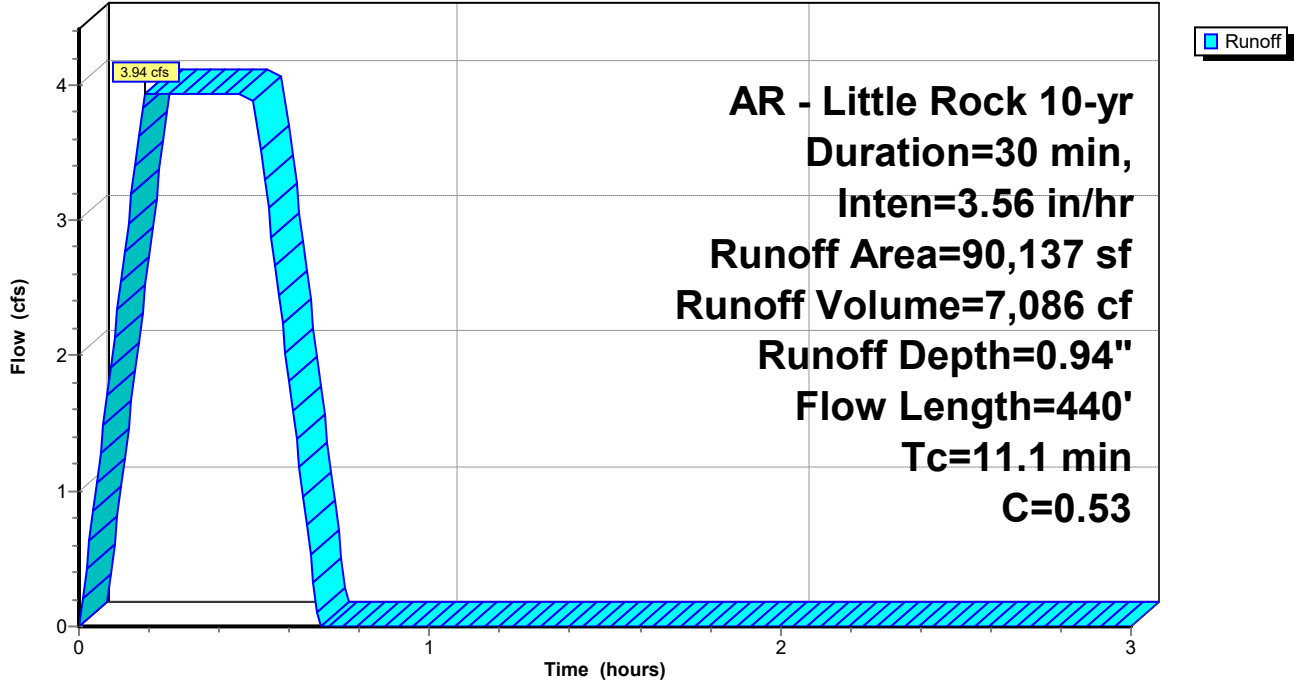

Summary for Subcatchment HIS PRE: Historic Pre-Development Discharge

Runoff = 13.48 cfs @ 0.47 hrs, Volume= 24,263 cf, Depth= 0.89"
 Routed to Link PRE : Pre Dev Runoff

Runoff by Rational method, Rise/Fall=1.0/1.0 xTc, Time Span= 0.00-3.00 hrs, dt= 0.01 hrs
 AR - Little Rock 10-yr Duration=30 min, Inten=3.56 in/hr

Area (ac)	C	Description
7.510	0.50	Undeveloped
7.510		100.00% Pervious Area

Tc (min)	Length (feet)	Slope (ft/ft)	Velocity (ft/sec)	Capacity (cfs)	Description
28.0					Direct Entry,

Subcatchment HIS PRE: Historic Pre-Development Discharge

Hydrograph

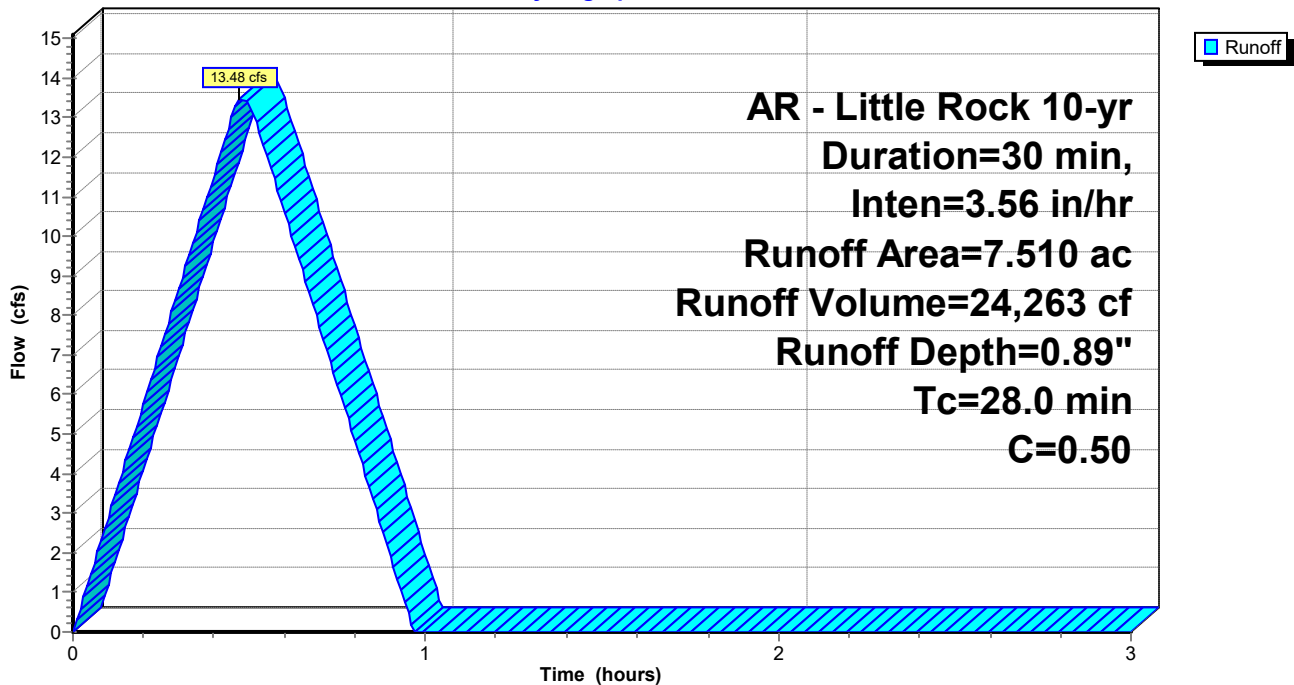

Summary for Link PRE: Pre Dev Runoff

Inflow Area = 507,112 sf, 0.00% Impervious, Inflow Depth = 0.93" for 10-yr event
Inflow = 21.93 cfs @ 0.47 hrs, Volume= 39,476 cf
Primary = 21.93 cfs @ 0.47 hrs, Volume= 39,476 cf, Atten= 0%, Lag= 0.0 min

Primary outflow = Inflow, Time Span= 0.00-3.00 hrs, dt= 0.01 hrs

Link PRE: Pre Dev Runoff

Hydrograph

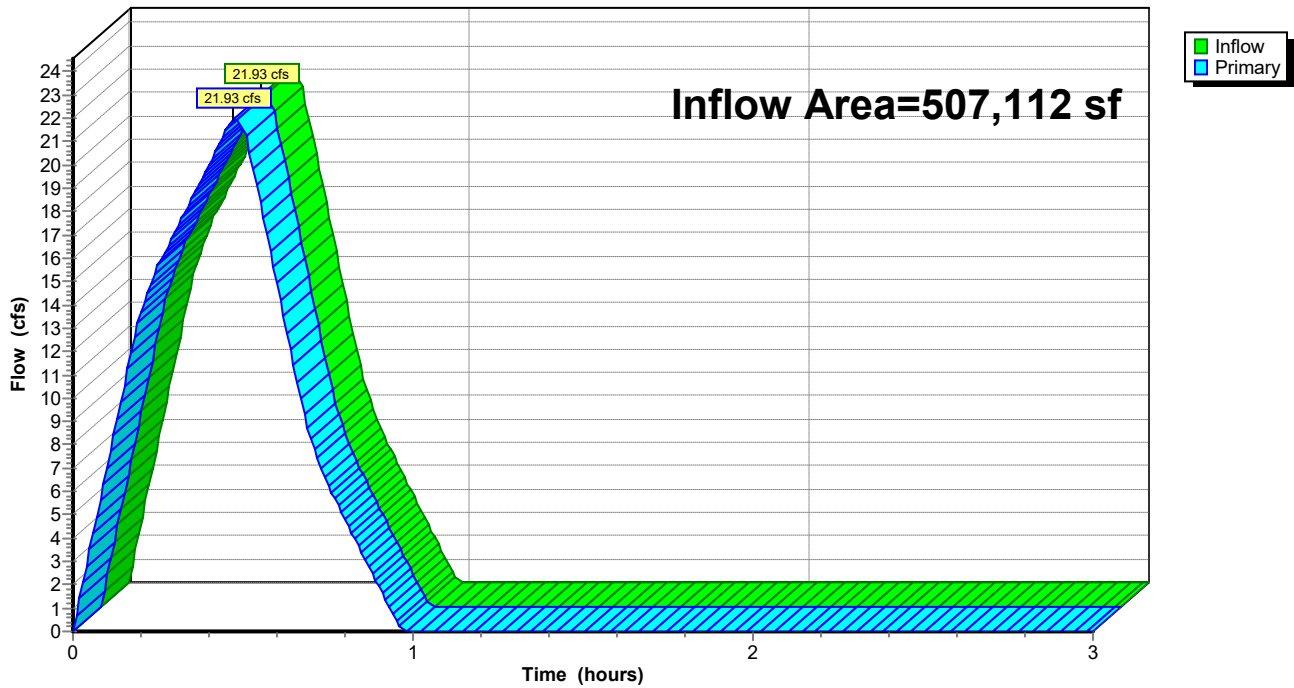

Goddard

Prepared by Phillip Lewis Engineering

HydroCAD® 10.20-5c s/n 12520 © 2023 HydroCAD Software Solutions LLC

AR - Little Rock 25-yr Duration=30 min, Inten=4.10 in/hr

Printed 3/25/2026

Summary for Subcatchment A1: Drainage Basin A1

Runoff = 1.32 cfs @ 0.21 hrs, Volume= 2,379 cf, Depth= 1.21"
 Routed to Link PRE : Pre Dev Runoff

Runoff by Rational method, Rise/Fall=1.0/1.0 xTc, Time Span= 0.00-3.00 hrs, dt= 0.01 hrs
 AR - Little Rock 25-yr Duration=30 min, Inten=4.10 in/hr

Area (sf)	C	Description
20,204	0.53	Undeveloped
3,399	0.92	Paving
23,603	0.59	Weighted Average
23,603		100.00% Pervious Area

Tc (min)	Length (feet)	Slope (ft/ft)	Velocity (ft/sec)	Capacity (cfs)	Description
6.1	48	0.0270	0.13		Sheet Flow, Sheet Flow
					Grass: Dense n= 0.240 P2= 4.19"
5.7	52	0.0380	0.15		Sheet Flow, Sheet Flow
					Grass: Dense n= 0.240 P2= 4.19"
0.3	37	0.0950	2.16		Shallow Concentrated Flow, Concentrated Flow
					Short Grass Pasture Kv= 7.0 fps
0.1	45	0.0860	5.95		Shallow Concentrated Flow, Concentrated Flow
					Paved Kv= 20.3 fps
0.1	17	0.0810	4.27		Shallow Concentrated Flow, Concentrated Flow
					Grassed Waterway Kv= 15.0 fps
0.0	16	0.0750	5.56		Shallow Concentrated Flow, Concentrated Flow
					Paved Kv= 20.3 fps
0.1	26	0.0710	5.41		Shallow Concentrated Flow, Concentrated Flow
					Paved Kv= 20.3 fps
0.1	32	0.0570	4.85		Shallow Concentrated Flow, Concentrated Flow
					Paved Kv= 20.3 fps
0.0	13	0.0470	4.40		Shallow Concentrated Flow, Concentrated Flow
					Paved Kv= 20.3 fps
12.5	286	Total			

Subcatchment A1: Drainage Basin A1

Hydrograph

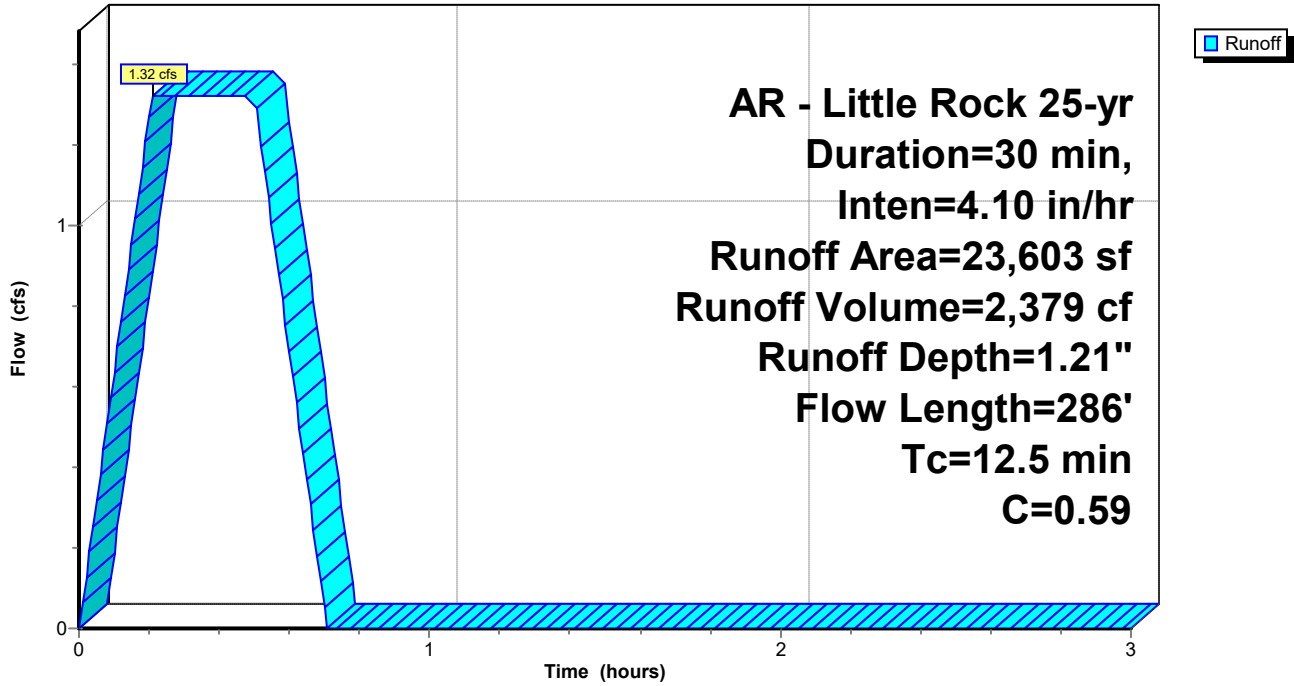

Goddard

Prepared by Phillip Lewis Engineering

HydroCAD® 10.20-5c s/n 12520 © 2023 HydroCAD Software Solutions LLC

AR - Little Rock 25-yr Duration=30 min, Inten=4.10 in/hr

Printed 3/25/2026

Summary for Subcatchment A2: Drainage Basin A2

Runoff = 3.18 cfs @ 0.25 hrs, Volume= 5,726 cf, Depth= 1.31"
 Routed to Link PRE : Pre Dev Runoff

Runoff by Rational method, Rise/Fall=1.0/1.0 xTc, Time Span= 0.00-3.00 hrs, dt= 0.01 hrs
 AR - Little Rock 25-yr Duration=30 min, Inten=4.10 in/hr

Area (sf)	C	Description
37,816	0.53	Undeveloped
14,559	0.92	Paving
52,375	0.64	Weighted Average
52,375		100.00% Pervious Area

Tc (min)	Length (feet)	Slope (ft/ft)	Velocity (ft/sec)	Capacity (cfs)	Description
4.6	36	0.0320	0.13		Sheet Flow, Sheet Flow Grass: Dense n= 0.240 P2= 4.19"
6.1	64	0.0480	0.17		Sheet Flow, Sheet Flow Grass: Dense n= 0.240 P2= 4.19"
0.9	76	0.0430	1.45		Shallow Concentrated Flow, Concentrated Flow Short Grass Pasture Kv= 7.0 fps
0.7	74	0.0710	1.87		Shallow Concentrated Flow, Concentrated Flow Short Grass Pasture Kv= 7.0 fps
0.2	36	0.1680	2.87		Shallow Concentrated Flow, Concentrated Flow Short Grass Pasture Kv= 7.0 fps
0.6	61	0.0070	1.70		Shallow Concentrated Flow, Concentrated Flow Paved Kv= 20.3 fps
0.2	38	0.0160	2.57		Shallow Concentrated Flow, Concentrated Flow Paved Kv= 20.3 fps
0.2	30	0.0190	2.80		Shallow Concentrated Flow, Concentrated Flow Paved Kv= 20.3 fps
1.3	216	0.0190	2.80		Shallow Concentrated Flow, Concentrated Flow Paved Kv= 20.3 fps
14.8	631	Total			

Subcatchment A2: Drainage Basin A2

Hydrograph

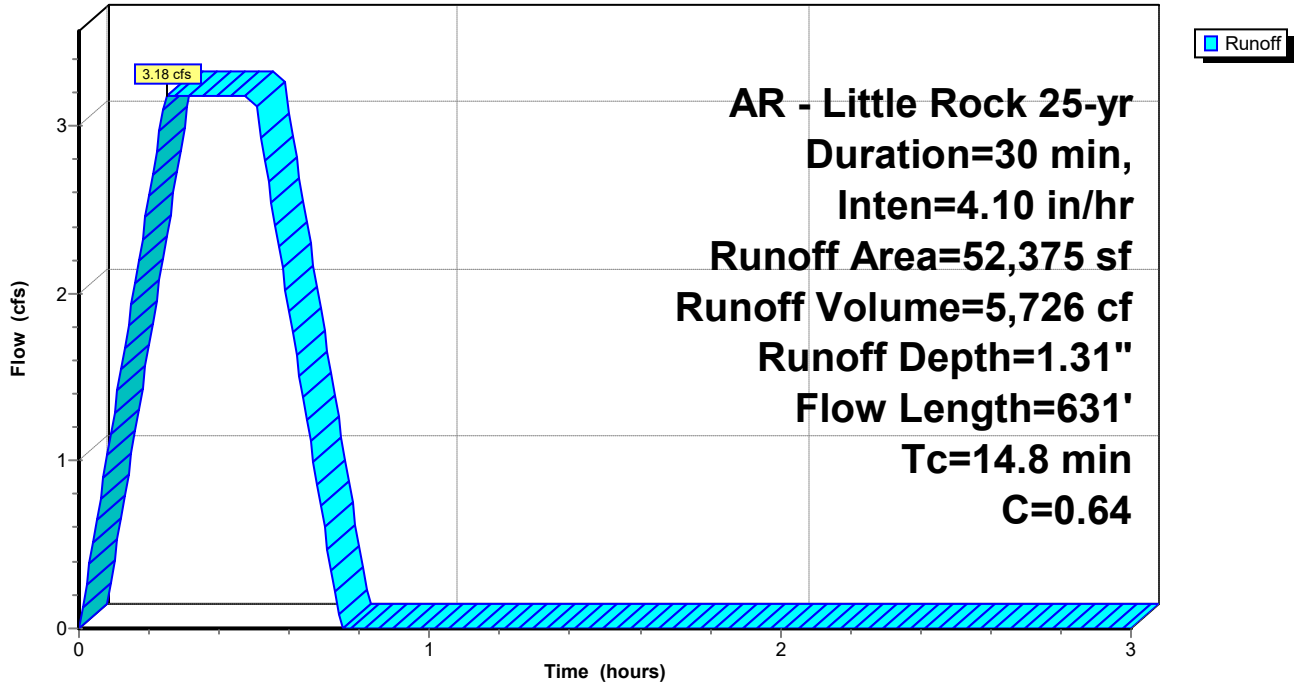

Goddard

Prepared by Phillip Lewis Engineering

HydroCAD® 10.20-5c s/n 12520 © 2023 HydroCAD Software Solutions LLC

AR - Little Rock 25-yr Duration=30 min, Inten=4.10 in/hr

Printed 3/25/2026

Summary for Subcatchment A3: Drainage Basin A3

Runoff = 0.70 cfs @ 0.19 hrs, Volume= 1,255 cf, Depth= 1.09"

Routed to Link PRE : Pre Dev Runoff

Runoff by Rational method, Rise/Fall=1.0/1.0 xTc, Time Span= 0.00-3.00 hrs, dt= 0.01 hrs

AR - Little Rock 25-yr Duration=30 min, Inten=4.10 in/hr

Area (sf)	C	Description
13,861	0.53	Undeveloped
0	0.92	Paving
13,861	0.53	Weighted Average
13,861		100.00% Pervious Area

Tc (min)	Length (feet)	Slope (ft/ft)	Velocity (ft/sec)	Capacity (cfs)	Description
8.4	100	0.0540	0.20		Sheet Flow, Sheet Flow Grass: Dense n= 0.240 P2= 4.19"
0.6	72	0.0790	1.97		Shallow Concentrated Flow, Concentrated Flow Short Grass Pasture Kv= 7.0 fps
0.2	21	0.0420	1.43		Shallow Concentrated Flow, Concentrated Flow Short Grass Pasture Kv= 7.0 fps
0.3	24	0.0400	1.40		Shallow Concentrated Flow, Concentrated Flow Short Grass Pasture Kv= 7.0 fps
1.4	102	0.0300	1.21		Shallow Concentrated Flow, Concentrated Flow Short Grass Pasture Kv= 7.0 fps
10.9	319	Total			

Subcatchment A3: Drainage Basin A3

Hydrograph

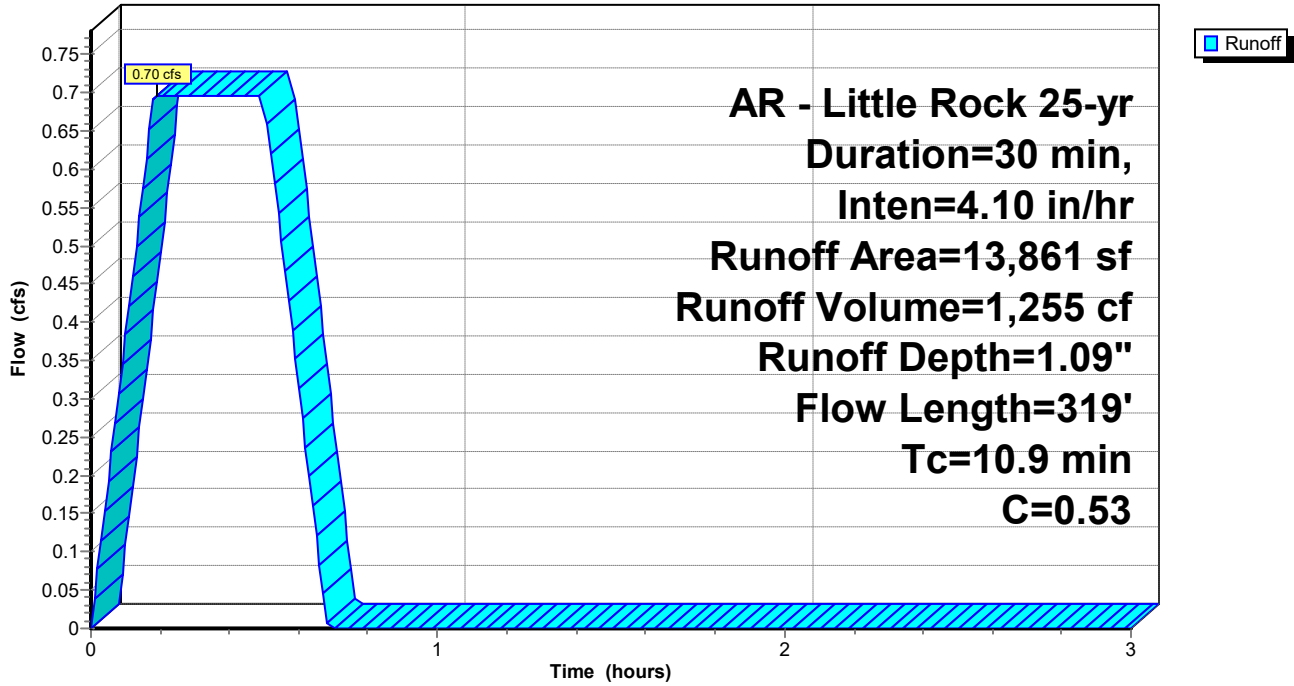

Goddard

Prepared by Phillip Lewis Engineering

HydroCAD® 10.20-5c s/n 12520 © 2023 HydroCAD Software Solutions LLC

AR - Little Rock 25-yr Duration=30 min, Inten=4.10 in/hr

Printed 3/25/2026

Summary for Subcatchment A4: Drainage Basin A4

Runoff = 4.53 cfs @ 0.19 hrs, Volume= 8,161 cf, Depth= 1.09"

Routed to Link PRE : Pre Dev Runoff

Runoff by Rational method, Rise/Fall=1.0/1.0 xTc, Time Span= 0.00-3.00 hrs, dt= 0.01 hrs

AR - Little Rock 25-yr Duration=30 min, Inten=4.10 in/hr

Area (sf)	C	Description
90,137	0.53	Undeveloped
0	0.92	Paving
90,137	0.53	Weighted Average
90,137		100.00% Pervious Area

Tc (min)	Length (feet)	Slope (ft/ft)	Velocity (ft/sec)	Capacity (cfs)	Description
7.1	100	0.0810	0.23		Sheet Flow, Sheet Flow
					Grass: Dense n= 0.240 P2= 4.19"
1.4	148	0.0680	1.83		Shallow Concentrated Flow, Concentrated Flow
					Short Grass Pasture Kv= 7.0 fps
0.2	26	0.1200	2.42		Shallow Concentrated Flow, Concentrated Flow
					Short Grass Pasture Kv= 7.0 fps
0.2	20	0.0410	1.42		Shallow Concentrated Flow, Concentrated Flow
					Short Grass Pasture Kv= 7.0 fps
0.6	51	0.0390	1.38		Shallow Concentrated Flow, Concentrated Flow
					Short Grass Pasture Kv= 7.0 fps
1.6	95	0.0210	1.01		Shallow Concentrated Flow, Concentrated Flow
					Short Grass Pasture Kv= 7.0 fps
11.1	440	Total			

Subcatchment A4: Drainage Basin A4

Hydrograph

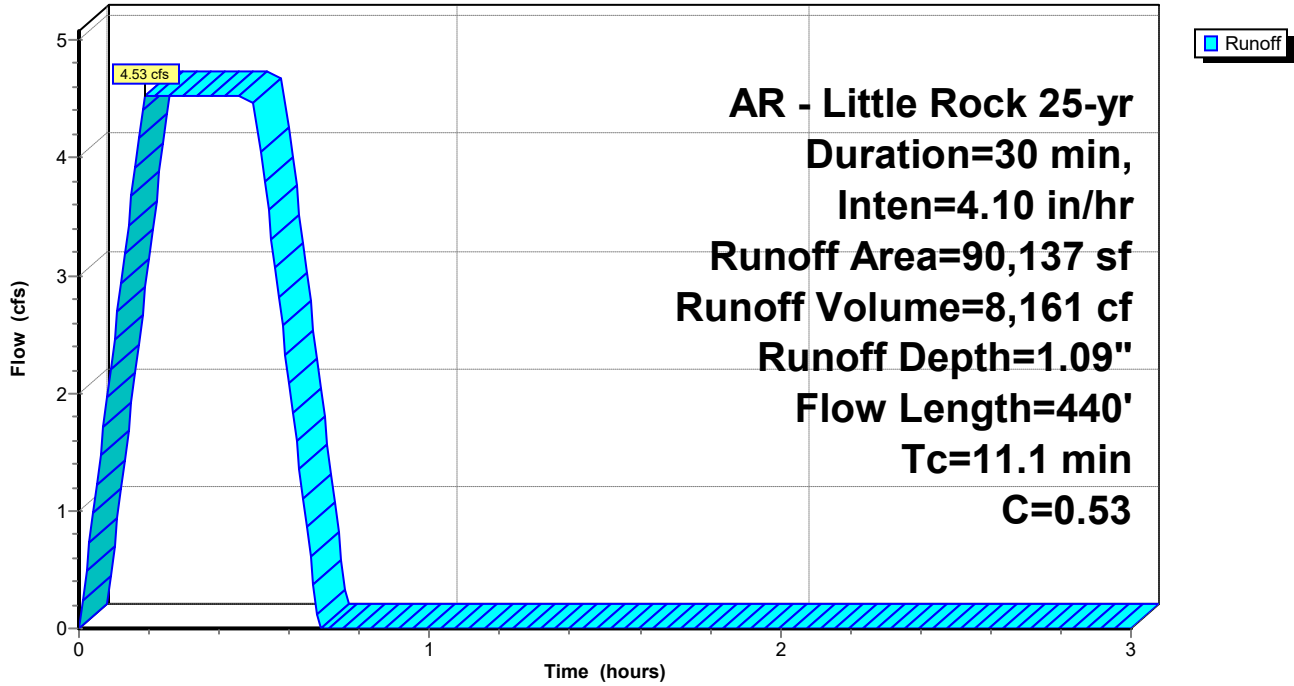

Summary for Subcatchment HIS PRE: Historic Pre-Development Discharge

Runoff = 15.52 cfs @ 0.47 hrs, Volume= 27,943 cf, Depth= 1.02"
 Routed to Link PRE : Pre Dev Runoff

Runoff by Rational method, Rise/Fall=1.0/1.0 xTc, Time Span= 0.00-3.00 hrs, dt= 0.01 hrs
 AR - Little Rock 25-yr Duration=30 min, Inten=4.10 in/hr

Area (ac)	C	Description
7.510	0.50	Undeveloped
7.510		100.00% Pervious Area

Tc (min)	Length (feet)	Slope (ft/ft)	Velocity (ft/sec)	Capacity (cfs)	Description
28.0					Direct Entry,

Subcatchment HIS PRE: Historic Pre-Development Discharge

Hydrograph

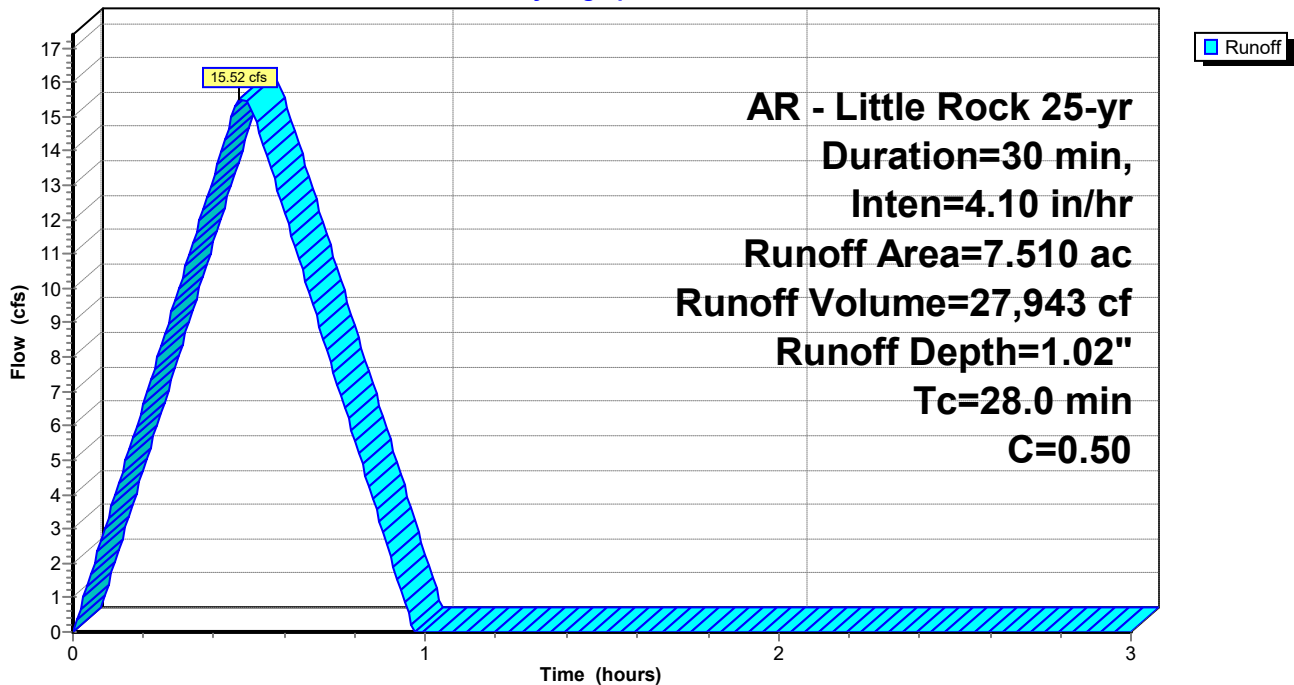

Summary for Link PRE: Pre Dev Runoff

Inflow Area = 507,112 sf, 0.00% Impervious, Inflow Depth = 1.08" for 25-yr event
Inflow = 25.26 cfs @ 0.47 hrs, Volume= 45,464 cf
Primary = 25.26 cfs @ 0.47 hrs, Volume= 45,464 cf, Atten= 0%, Lag= 0.0 min

Primary outflow = Inflow, Time Span= 0.00-3.00 hrs, dt= 0.01 hrs

Link PRE: Pre Dev Runoff

Hydrograph

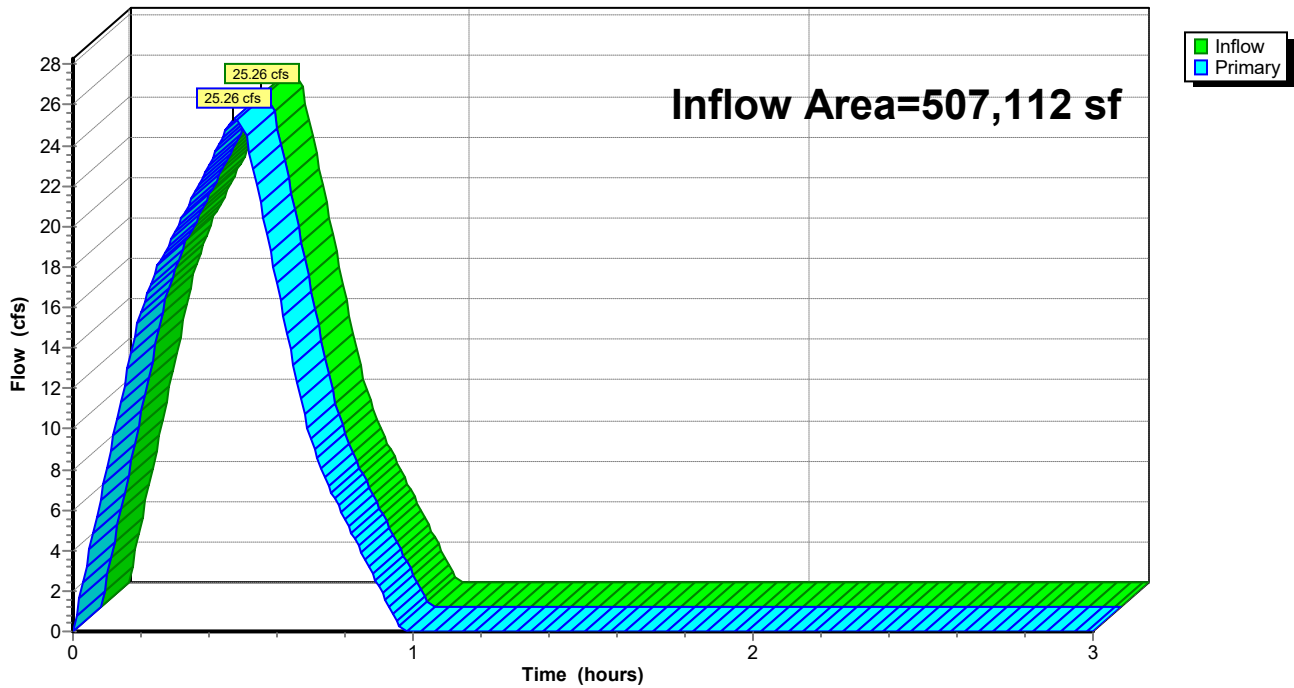

Goddard

Prepared by Phillip Lewis Engineering

HydroCAD® 10.20-5c s/n 12520 © 2023 HydroCAD Software Solutions LLC

AR - Little Rock 100-yr Duration=30 min, Inten=4.88 in/hr

Printed 3/25/2026

Summary for Subcatchment A1: Drainage Basin A1

Runoff = 1.57 cfs @ 0.21 hrs, Volume= 2,832 cf, Depth= 1.44"
 Routed to Link PRE : Pre Dev Runoff

Runoff by Rational method, Rise/Fall=1.0/1.0 xTc, Time Span= 0.00-3.00 hrs, dt= 0.01 hrs
 AR - Little Rock 100-yr Duration=30 min, Inten=4.88 in/hr

Area (sf)	C	Description
20,204	0.53	Undeveloped
3,399	0.92	Paving
23,603	0.59	Weighted Average
23,603		100.00% Pervious Area

Tc (min)	Length (feet)	Slope (ft/ft)	Velocity (ft/sec)	Capacity (cfs)	Description
6.1	48	0.0270	0.13		Sheet Flow, Sheet Flow
					Grass: Dense n= 0.240 P2= 4.19"
5.7	52	0.0380	0.15		Sheet Flow, Sheet Flow
					Grass: Dense n= 0.240 P2= 4.19"
0.3	37	0.0950	2.16		Shallow Concentrated Flow, Concentrated Flow
					Short Grass Pasture Kv= 7.0 fps
0.1	45	0.0860	5.95		Shallow Concentrated Flow, Concentrated Flow
					Paved Kv= 20.3 fps
0.1	17	0.0810	4.27		Shallow Concentrated Flow, Concentrated Flow
					Grassed Waterway Kv= 15.0 fps
0.0	16	0.0750	5.56		Shallow Concentrated Flow, Concentrated Flow
					Paved Kv= 20.3 fps
0.1	26	0.0710	5.41		Shallow Concentrated Flow, Concentrated Flow
					Paved Kv= 20.3 fps
0.1	32	0.0570	4.85		Shallow Concentrated Flow, Concentrated Flow
					Paved Kv= 20.3 fps
0.0	13	0.0470	4.40		Shallow Concentrated Flow, Concentrated Flow
					Paved Kv= 20.3 fps
12.5	286	Total			

Subcatchment A1: Drainage Basin A1

Hydrograph

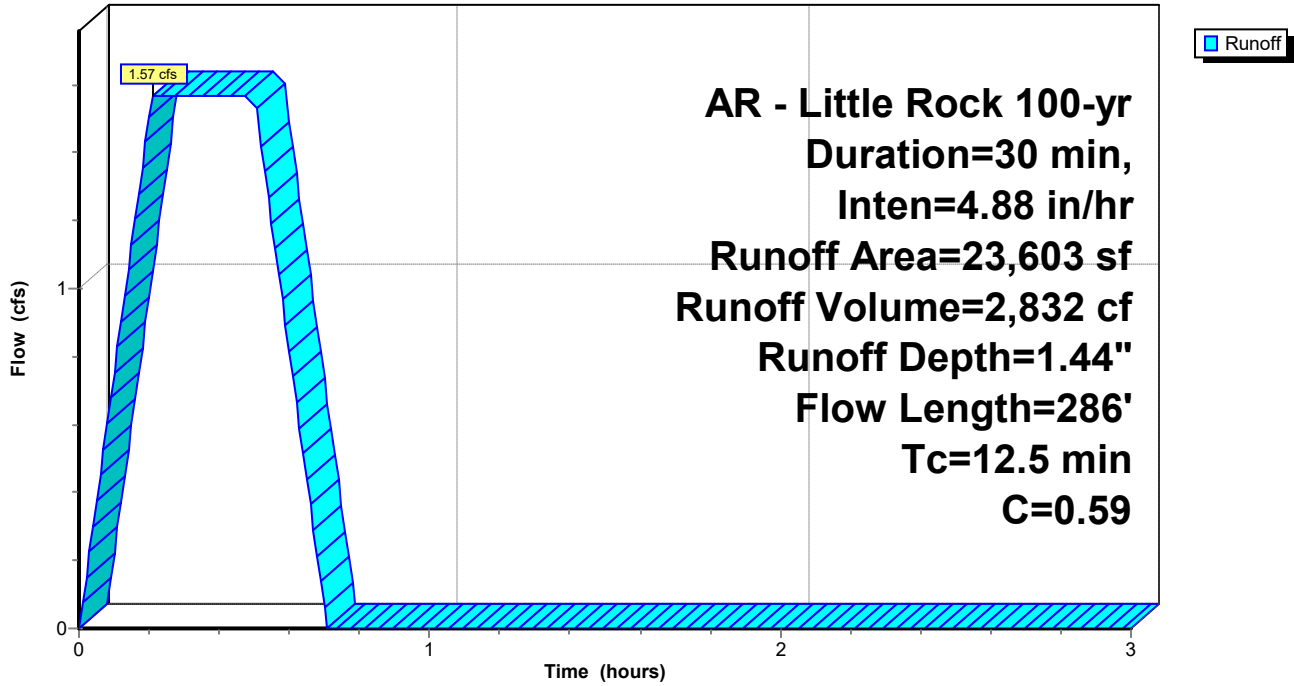

Summary for Subcatchment A2: Drainage Basin A2

Runoff = 3.79 cfs @ 0.25 hrs, Volume= 6,816 cf, Depth= 1.56"
 Routed to Link PRE : Pre Dev Runoff

Runoff by Rational method, Rise/Fall=1.0/1.0 xTc, Time Span= 0.00-3.00 hrs, dt= 0.01 hrs
 AR - Little Rock 100-yr Duration=30 min, Inten=4.88 in/hr

Area (sf)	C	Description
37,816	0.53	Undeveloped
14,559	0.92	Paving
52,375	0.64	Weighted Average
52,375		100.00% Pervious Area

Tc (min)	Length (feet)	Slope (ft/ft)	Velocity (ft/sec)	Capacity (cfs)	Description
4.6	36	0.0320	0.13		Sheet Flow, Sheet Flow Grass: Dense n= 0.240 P2= 4.19"
6.1	64	0.0480	0.17		Sheet Flow, Sheet Flow Grass: Dense n= 0.240 P2= 4.19"
0.9	76	0.0430	1.45		Shallow Concentrated Flow, Concentrated Flow Short Grass Pasture Kv= 7.0 fps
0.7	74	0.0710	1.87		Shallow Concentrated Flow, Concentrated Flow Short Grass Pasture Kv= 7.0 fps
0.2	36	0.1680	2.87		Shallow Concentrated Flow, Concentrated Flow Short Grass Pasture Kv= 7.0 fps
0.6	61	0.0070	1.70		Shallow Concentrated Flow, Concentrated Flow Paved Kv= 20.3 fps
0.2	38	0.0160	2.57		Shallow Concentrated Flow, Concentrated Flow Paved Kv= 20.3 fps
0.2	30	0.0190	2.80		Shallow Concentrated Flow, Concentrated Flow Paved Kv= 20.3 fps
1.3	216	0.0190	2.80		Shallow Concentrated Flow, Concentrated Flow Paved Kv= 20.3 fps
14.8	631	Total			

Subcatchment A2: Drainage Basin A2

Hydrograph

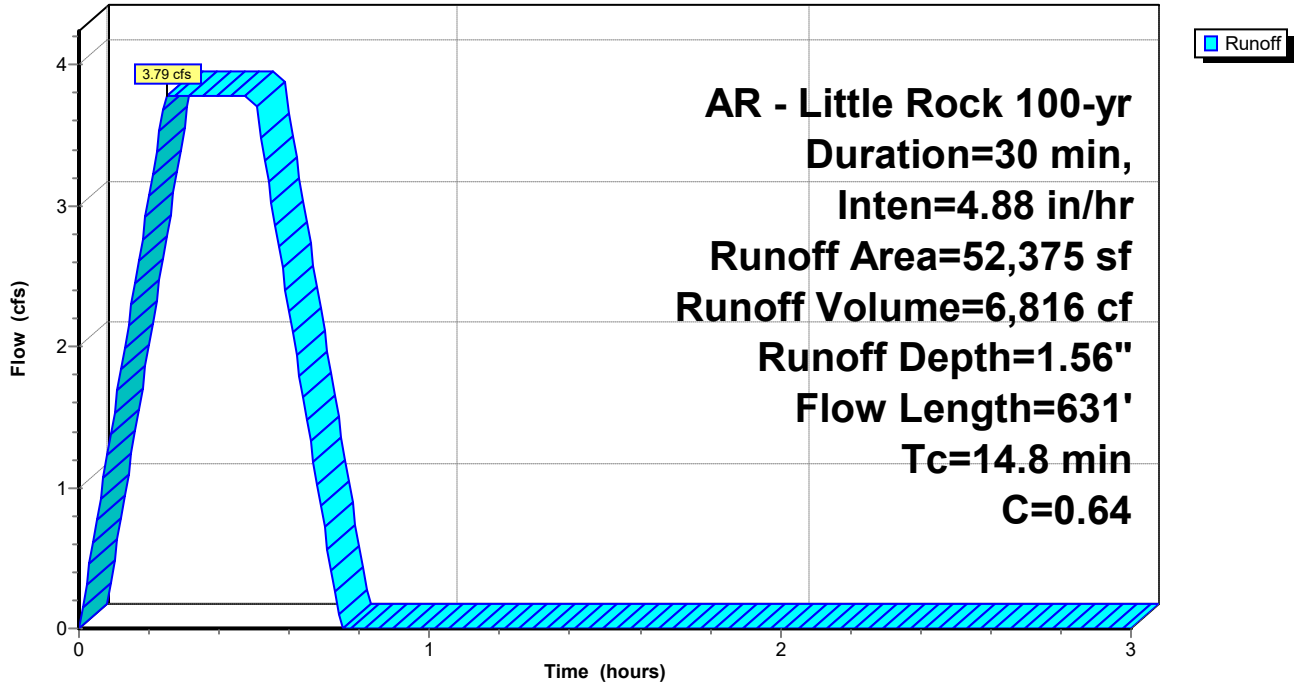

Goddard

AR - Little Rock 100-yr Duration=30 min, Inten=4.88 in/hr

Prepared by Phillip Lewis Engineering

Printed 3/25/2026

HydroCAD® 10.20-5c s/n 12520 © 2023 HydroCAD Software Solutions LLC

Summary for Subcatchment A3: Drainage Basin A3

Runoff = 0.83 cfs @ 0.19 hrs, Volume= 1,494 cf, Depth= 1.29"
 Routed to Link PRE : Pre Dev Runoff

Runoff by Rational method, Rise/Fall=1.0/1.0 xTc, Time Span= 0.00-3.00 hrs, dt= 0.01 hrs
 AR - Little Rock 100-yr Duration=30 min, Inten=4.88 in/hr

Area (sf)	C	Description
13,861	0.53	Undeveloped
0	0.92	Paving
13,861	0.53	Weighted Average
13,861		100.00% Pervious Area

Tc (min)	Length (feet)	Slope (ft/ft)	Velocity (ft/sec)	Capacity (cfs)	Description
8.4	100	0.0540	0.20		Sheet Flow, Sheet Flow Grass: Dense n= 0.240 P2= 4.19"
0.6	72	0.0790	1.97		Shallow Concentrated Flow, Concentrated Flow Short Grass Pasture Kv= 7.0 fps
0.2	21	0.0420	1.43		Shallow Concentrated Flow, Concentrated Flow Short Grass Pasture Kv= 7.0 fps
0.3	24	0.0400	1.40		Shallow Concentrated Flow, Concentrated Flow Short Grass Pasture Kv= 7.0 fps
1.4	102	0.0300	1.21		Shallow Concentrated Flow, Concentrated Flow Short Grass Pasture Kv= 7.0 fps
10.9	319	Total			

Subcatchment A3: Drainage Basin A3

Hydrograph

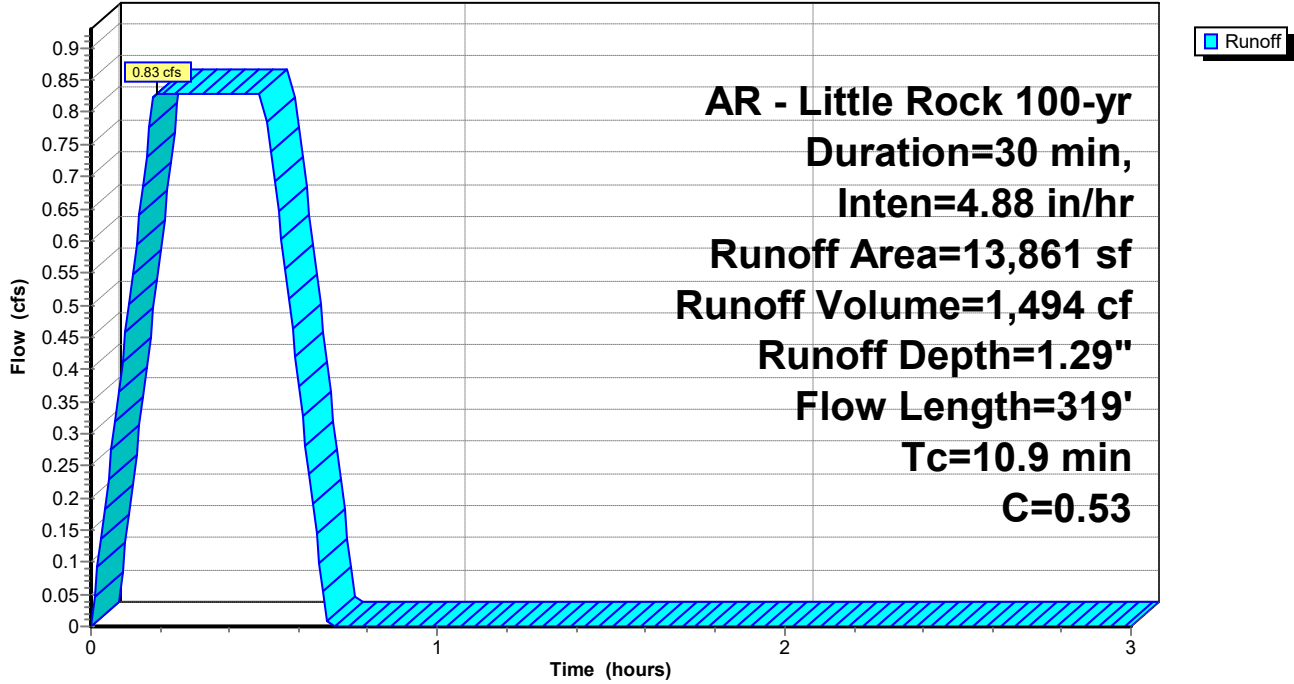

Goddard

Prepared by Phillip Lewis Engineering

HydroCAD® 10.20-5c s/n 12520 © 2023 HydroCAD Software Solutions LLC

AR - Little Rock 100-yr Duration=30 min, Inten=4.88 in/hr

Printed 3/25/2026

Summary for Subcatchment A4: Drainage Basin A4

Runoff = 5.40 cfs @ 0.19 hrs, Volume= 9,714 cf, Depth= 1.29"
 Routed to Link PRE : Pre Dev Runoff

Runoff by Rational method, Rise/Fall=1.0/1.0 xTc, Time Span= 0.00-3.00 hrs, dt= 0.01 hrs
 AR - Little Rock 100-yr Duration=30 min, Inten=4.88 in/hr

Area (sf)	C	Description
90,137	0.53	Undeveloped
0	0.92	Paving
90,137	0.53	Weighted Average
90,137		100.00% Pervious Area

Tc (min)	Length (feet)	Slope (ft/ft)	Velocity (ft/sec)	Capacity (cfs)	Description
7.1	100	0.0810	0.23		Sheet Flow, Sheet Flow
					Grass: Dense n= 0.240 P2= 4.19"
1.4	148	0.0680	1.83		Shallow Concentrated Flow, Concentrated Flow
					Short Grass Pasture Kv= 7.0 fps
0.2	26	0.1200	2.42		Shallow Concentrated Flow, Concentrated Flow
					Short Grass Pasture Kv= 7.0 fps
0.2	20	0.0410	1.42		Shallow Concentrated Flow, Concentrated Flow
					Short Grass Pasture Kv= 7.0 fps
0.6	51	0.0390	1.38		Shallow Concentrated Flow, Concentrated Flow
					Short Grass Pasture Kv= 7.0 fps
1.6	95	0.0210	1.01		Shallow Concentrated Flow, Concentrated Flow
					Short Grass Pasture Kv= 7.0 fps
11.1	440	Total			

Subcatchment A4: Drainage Basin A4

Hydrograph

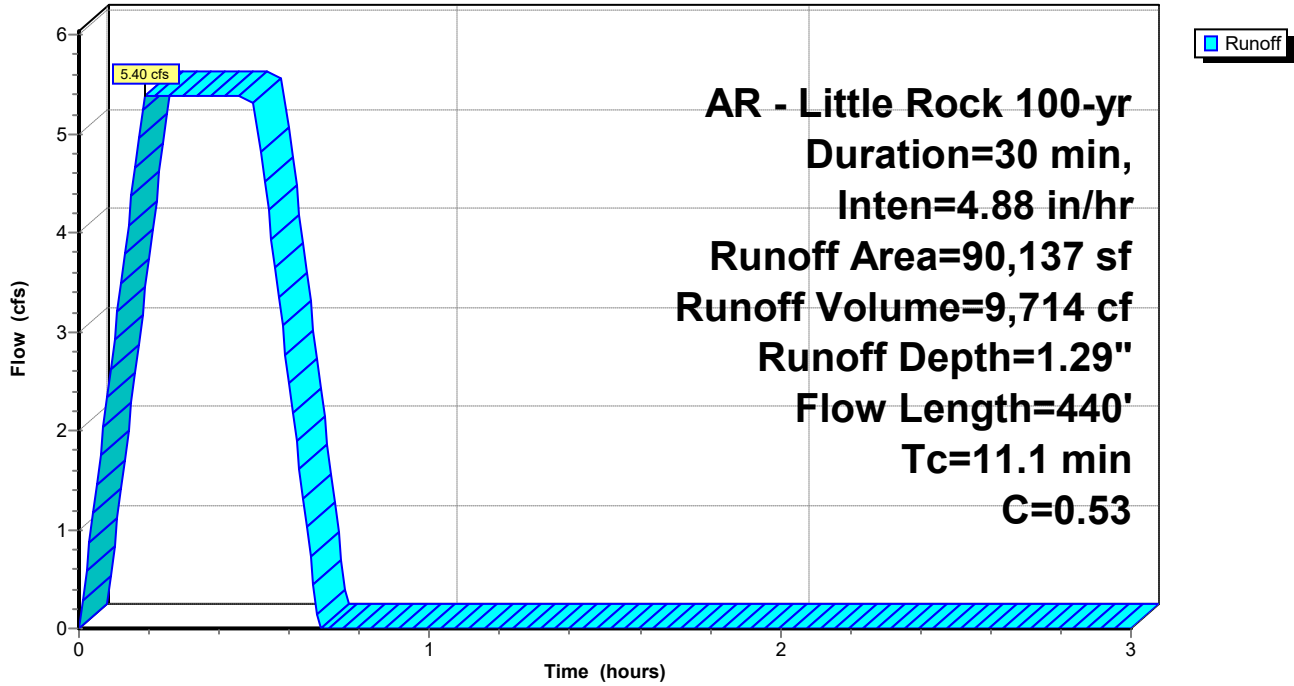

Summary for Subcatchment HIS PRE: Historic Pre-Development Discharge

Runoff = 18.48 cfs @ 0.47 hrs, Volume= 33,259 cf, Depth= 1.22"
 Routed to Link PRE : Pre Dev Runoff

Runoff by Rational method, Rise/Fall=1.0/1.0 xTc, Time Span= 0.00-3.00 hrs, dt= 0.01 hrs
 AR - Little Rock 100-yr Duration=30 min, Inten=4.88 in/hr

Area (ac)	C	Description
7.510	0.50	Undeveloped
7.510		100.00% Pervious Area

Tc (min)	Length (feet)	Slope (ft/ft)	Velocity (ft/sec)	Capacity (cfs)	Description
28.0					Direct Entry,

Subcatchment HIS PRE: Historic Pre-Development Discharge

Hydrograph

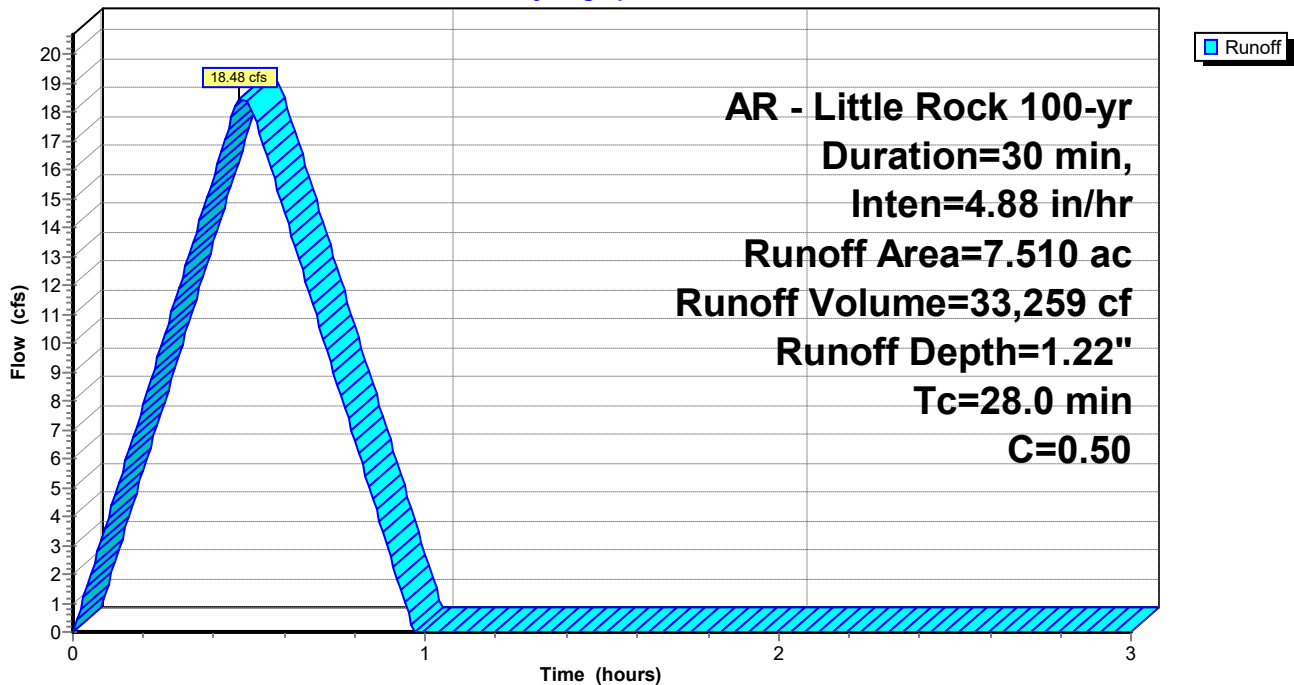

Summary for Link PRE: Pre Dev Runoff

Inflow Area = 507,112 sf, 0.00% Impervious, Inflow Depth = 1.28" for 100-yr event
Inflow = 30.06 cfs @ 0.47 hrs, Volume= 54,114 cf
Primary = 30.06 cfs @ 0.47 hrs, Volume= 54,114 cf, Atten= 0%, Lag= 0.0 min

Primary outflow = Inflow, Time Span= 0.00-3.00 hrs, dt= 0.01 hrs

Link PRE: Pre Dev Runoff

Hydrograph

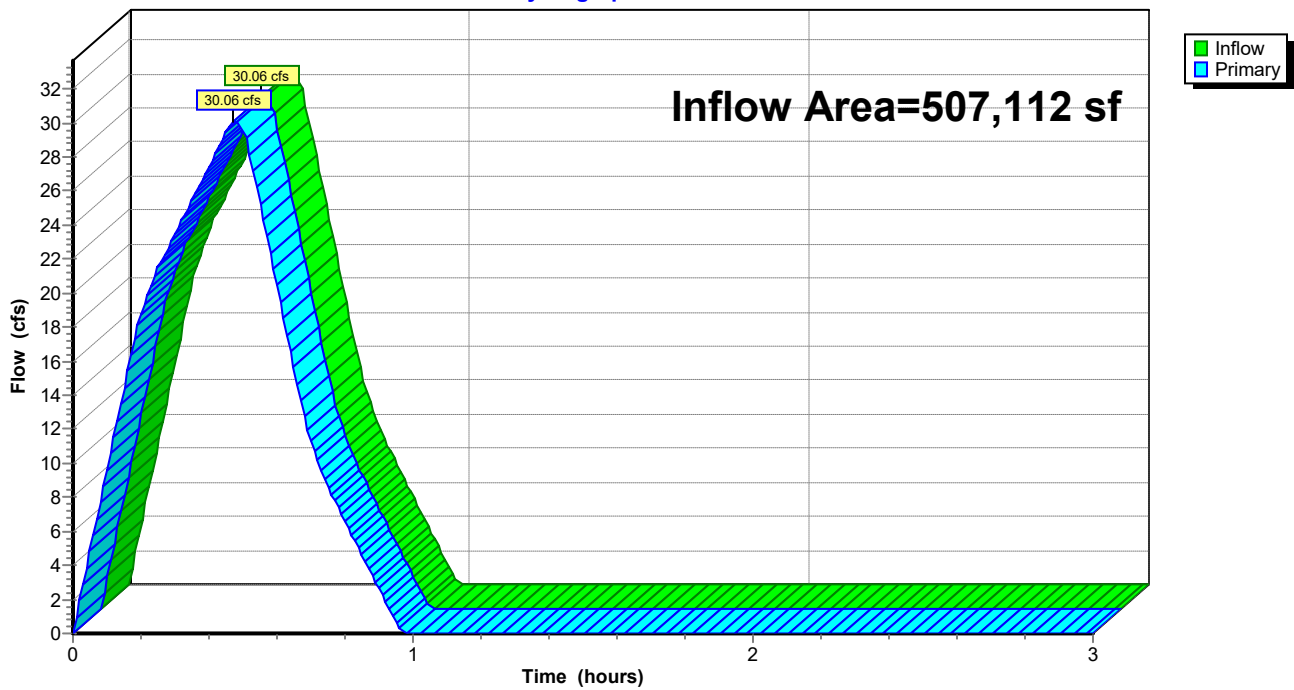

POST DEVELOPMENT SUMMARY

Goddard

Prepared by Phillip Lewis Engineering

HydroCAD® 10.20-5c s/n 12520 © 2023 HydroCAD Software Solutions LLC

AR - Little Rock 2-yr Duration=20 min, Inten=3.13 in/hr

Printed 3/25/2026

Time span=0.00-3.00 hrs, dt=0.01 hrs, 301 points

Runoff by Rational method, Rise/Fall=1.0/1.0 xTc

Reach routing by Stor-Ind+Trans method - Pond routing by Stor-Ind method

Subcatchment B1: Drainage Basin B1	Runoff Area=74,767 sf 0.81% Impervious Runoff Depth=0.55" Flow Length=442' Tc=18.5 min C=0.53 Runoff=2.87 cfs 3,450 cf
Subcatchment B2: Drainage Basin B2	Runoff Area=6,762 sf 2.47% Impervious Runoff Depth=0.54" Flow Length=61' Tc=5.8 min C=0.52 Runoff=0.26 cfs 306 cf
Subcatchment B3: Drainage Basin B3	Runoff Area=33,289 sf 43.74% Impervious Runoff Depth=0.73" Flow Length=610' Tc=15.4 min C=0.70 Runoff=1.69 cfs 2,028 cf
Subcatchment B4: Drainage Basin B4	Runoff Area=19,493 sf 74.78% Impervious Runoff Depth=0.88" Flow Length=249' Tc=5.0 min C=0.84 Runoff=1.19 cfs 1,425 cf
Subcatchment B5: Drainage Basin B5	Runoff Area=9,275 sf 100.00% Impervious Runoff Depth=0.99" Tc=5.0 min C=0.95 Runoff=0.64 cfs 767 cf
Subcatchment B6: Drainage Basin B6	Runoff Area=1,887 sf 100.00% Impervious Runoff Depth=0.99" Flow Length=507' Tc=5.0 min C=0.95 Runoff=0.13 cfs 156 cf
Subcatchment B7: Drainage Basin B7	Runoff Area=22,169 sf 29.72% Impervious Runoff Depth=0.67" Flow Length=182' Tc=10.0 min C=0.64 Runoff=1.03 cfs 1,235 cf
Subcatchment B8: Drainage Basin B8	Runoff Area=14,440 sf 44.72% Impervious Runoff Depth=0.74" Flow Length=127' Tc=14.0 min C=0.71 Runoff=0.74 cfs 892 cf
Subcatchment C1: Drainage Basin C1	Runoff Area=20,337 sf 69.83% Impervious Runoff Depth=0.81" Flow Length=134' Tc=5.2 min C=0.78 Runoff=1.15 cfs 1,380 cf
Subcatchment C10: Drainage Basin C10	Runoff Area=5,408 sf 77.35% Impervious Runoff Depth=0.87" Flow Length=582' Tc=5.0 min C=0.83 Runoff=0.33 cfs 391 cf
Subcatchment C11: Drainage Basin C11	Runoff Area=6,183 sf 53.49% Impervious Runoff Depth=0.72" Flow Length=633' Tc=5.0 min C=0.69 Runoff=0.31 cfs 371 cf
Subcatchment C12: Drainage Basin C12	Runoff Area=25,658 sf 71.87% Impervious Runoff Depth=0.84" Flow Length=880' Tc=5.0 min C=0.80 Runoff=1.49 cfs 1,786 cf
Subcatchment C13: Drainage Basin C13	Runoff Area=7,946 sf 80.39% Impervious Runoff Depth=0.88" Flow Length=777' Tc=5.0 min C=0.84 Runoff=0.48 cfs 581 cf
Subcatchment C14: Drainage Basin C14	Runoff Area=22,025 sf 72.18% Impervious Runoff Depth=0.84" Flow Length=492' Tc=15.9 min C=0.80 Runoff=1.28 cfs 1,534 cf
Subcatchment C15: Drainage Basin C15	Runoff Area=13,450 sf 100.00% Impervious Runoff Depth=0.99" Flow Length=415' Tc=5.0 min C=0.95 Runoff=0.93 cfs 1,112 cf
Subcatchment C16: Drainage Basin C16	Runoff Area=22,077 sf 29.95% Impervious Runoff Depth=0.58" Flow Length=714' Tc=5.0 min C=0.56 Runoff=0.90 cfs 1,076 cf

Goddard

Prepared by Phillip Lewis Engineering

HydroCAD® 10.20-5c s/n 12520 © 2023 HydroCAD Software Solutions LLC

AR - Little Rock 2-yr Duration=20 min, Inten=3.13 in/hr

Printed 3/25/2026

Subcatchment C17: Drainage Basin C17	Runoff Area=56,749 sf 0.00% Impervious Runoff Depth=0.42" Flow Length=298' Tc=9.6 min C=0.40 Runoff=1.65 cfs 1,976 cf
Subcatchment C18: Drainage Basin C18	Runoff Area=22,785 sf 43.77% Impervious Runoff Depth=0.67" Flow Length=520' Tc=5.0 min C=0.64 Runoff=1.06 cfs 1,269 cf
Subcatchment C19: Drainage Basin C19	Runoff Area=18,009 sf 0.00% Impervious Runoff Depth=0.42" Flow Length=393' Tc=7.2 min C=0.40 Runoff=0.52 cfs 627 cf
Subcatchment C2: Drainage Basin C2	Runoff Area=34,339 sf 66.87% Impervious Runoff Depth=0.80" Flow Length=695' Tc=5.0 min C=0.77 Runoff=1.92 cfs 2,301 cf
Subcatchment C20: Drainage Basin C20	Runoff Area=30,789 sf 0.00% Impervious Runoff Depth=0.42" Flow Length=205' Tc=7.9 min C=0.40 Runoff=0.89 cfs 1,072 cf
Subcatchment C3: Drainage Basin C3	Runoff Area=3,480 sf 100.00% Impervious Runoff Depth=0.99" Flow Length=612' Tc=5.0 min C=0.95 Runoff=0.24 cfs 288 cf
Subcatchment C4: Drainage Basin C4	Runoff Area=11,375 sf 28.53% Impervious Runoff Depth=0.58" Flow Length=415' Tc=5.0 min C=0.56 Runoff=0.46 cfs 554 cf
Subcatchment C5: Drainage Basin C5	Runoff Area=6,695 sf 75.59% Impervious Runoff Depth=0.86" Flow Length=176' Tc=5.6 min C=0.82 Runoff=0.40 cfs 478 cf
Subcatchment C6: Drainage Basin C6	Runoff Area=2,835 sf 100.00% Impervious Runoff Depth=0.99" Flow Length=554' Tc=5.0 min C=0.95 Runoff=0.20 cfs 234 cf
Subcatchment C7: Drainage Basin C7	Runoff Area=1,597 sf 100.00% Impervious Runoff Depth=0.99" Flow Length=531' Tc=5.0 min C=0.95 Runoff=0.11 cfs 132 cf
Subcatchment C8: Drainage Basin C8	Runoff Area=1,548 sf 100.00% Impervious Runoff Depth=0.99" Flow Length=527' Tc=5.0 min C=0.95 Runoff=0.11 cfs 128 cf
Subcatchment C9: Drainage Basin C9	Runoff Area=13,817 sf 67.75% Impervious Runoff Depth=0.80" Flow Length=709' Tc=5.0 min C=0.77 Runoff=0.77 cfs 926 cf

Goddard

Prepared by Phillip Lewis Engineering

HydroCAD® 10.20-5c s/n 12520 © 2023 HydroCAD Software Solutions LLC

AR - Little Rock 5-yr Duration=20 min, Inten=3.73 in/hr

Printed 3/25/2026

Time span=0.00-3.00 hrs, dt=0.01 hrs, 301 points

Runoff by Rational method, Rise/Fall=1.0/1.0 xTc

Reach routing by Stor-Ind+Trans method - Pond routing by Stor-Ind method

Subcatchment B1: Drainage Basin B1	Runoff Area=74,767 sf 0.81% Impervious Runoff Depth=0.66" Flow Length=442' Tc=18.5 min C=0.53 Runoff=3.42 cfs 4,108 cf
Subcatchment B2: Drainage Basin B2	Runoff Area=6,762 sf 2.47% Impervious Runoff Depth=0.65" Flow Length=61' Tc=5.8 min C=0.52 Runoff=0.30 cfs 364 cf
Subcatchment B3: Drainage Basin B3	Runoff Area=33,289 sf 43.74% Impervious Runoff Depth=0.87" Flow Length=610' Tc=15.4 min C=0.70 Runoff=2.01 cfs 2,415 cf
Subcatchment B4: Drainage Basin B4	Runoff Area=19,493 sf 74.78% Impervious Runoff Depth=1.04" Flow Length=249' Tc=5.0 min C=0.84 Runoff=1.41 cfs 1,697 cf
Subcatchment B5: Drainage Basin B5	Runoff Area=9,275 sf 100.00% Impervious Runoff Depth=1.18" Tc=5.0 min C=0.95 Runoff=0.76 cfs 913 cf
Subcatchment B6: Drainage Basin B6	Runoff Area=1,887 sf 100.00% Impervious Runoff Depth=1.18" Flow Length=507' Tc=5.0 min C=0.95 Runoff=0.15 cfs 186 cf
Subcatchment B7: Drainage Basin B7	Runoff Area=22,169 sf 29.72% Impervious Runoff Depth=0.80" Flow Length=182' Tc=10.0 min C=0.64 Runoff=1.23 cfs 1,470 cf
Subcatchment B8: Drainage Basin B8	Runoff Area=14,440 sf 44.72% Impervious Runoff Depth=0.88" Flow Length=127' Tc=14.0 min C=0.71 Runoff=0.89 cfs 1,063 cf
Subcatchment C1: Drainage Basin C1	Runoff Area=20,337 sf 69.83% Impervious Runoff Depth=0.97" Flow Length=134' Tc=5.2 min C=0.78 Runoff=1.37 cfs 1,643 cf
Subcatchment C10: Drainage Basin C10	Runoff Area=5,408 sf 77.35% Impervious Runoff Depth=1.03" Flow Length=582' Tc=5.0 min C=0.83 Runoff=0.39 cfs 465 cf
Subcatchment C11: Drainage Basin C11	Runoff Area=6,183 sf 53.49% Impervious Runoff Depth=0.86" Flow Length=633' Tc=5.0 min C=0.69 Runoff=0.37 cfs 442 cf
Subcatchment C12: Drainage Basin C12	Runoff Area=25,658 sf 71.87% Impervious Runoff Depth=0.99" Flow Length=880' Tc=5.0 min C=0.80 Runoff=1.77 cfs 2,127 cf
Subcatchment C13: Drainage Basin C13	Runoff Area=7,946 sf 80.39% Impervious Runoff Depth=1.04" Flow Length=777' Tc=5.0 min C=0.84 Runoff=0.58 cfs 692 cf
Subcatchment C14: Drainage Basin C14	Runoff Area=22,025 sf 72.18% Impervious Runoff Depth=1.00" Flow Length=492' Tc=15.9 min C=0.80 Runoff=1.52 cfs 1,826 cf
Subcatchment C15: Drainage Basin C15	Runoff Area=13,450 sf 100.00% Impervious Runoff Depth=1.18" Flow Length=415' Tc=5.0 min C=0.95 Runoff=1.10 cfs 1,324 cf
Subcatchment C16: Drainage Basin C16	Runoff Area=22,077 sf 29.95% Impervious Runoff Depth=0.70" Flow Length=714' Tc=5.0 min C=0.56 Runoff=1.07 cfs 1,281 cf

Goddard

Prepared by Phillip Lewis Engineering

HydroCAD® 10.20-5c s/n 12520 © 2023 HydroCAD Software Solutions LLC

AR - Little Rock 5-yr Duration=20 min, Inten=3.73 in/hr

Printed 3/25/2026

Subcatchment C17: Drainage Basin C17	Runoff Area=56,749 sf 0.00% Impervious Runoff Depth=0.50" Flow Length=298' Tc=9.6 min C=0.40 Runoff=1.96 cfs 2,353 cf
Subcatchment C18: Drainage Basin C18	Runoff Area=22,785 sf 43.77% Impervious Runoff Depth=0.80" Flow Length=520' Tc=5.0 min C=0.64 Runoff=1.26 cfs 1,511 cf
Subcatchment C19: Drainage Basin C19	Runoff Area=18,009 sf 0.00% Impervious Runoff Depth=0.50" Flow Length=393' Tc=7.2 min C=0.40 Runoff=0.62 cfs 747 cf
Subcatchment C2: Drainage Basin C2	Runoff Area=34,339 sf 66.87% Impervious Runoff Depth=0.96" Flow Length=695' Tc=5.0 min C=0.77 Runoff=2.28 cfs 2,740 cf
Subcatchment C20: Drainage Basin C20	Runoff Area=30,789 sf 0.00% Impervious Runoff Depth=0.50" Flow Length=205' Tc=7.9 min C=0.40 Runoff=1.06 cfs 1,277 cf
Subcatchment C3: Drainage Basin C3	Runoff Area=3,480 sf 100.00% Impervious Runoff Depth=1.18" Flow Length=612' Tc=5.0 min C=0.95 Runoff=0.29 cfs 343 cf
Subcatchment C4: Drainage Basin C4	Runoff Area=11,375 sf 28.53% Impervious Runoff Depth=0.70" Flow Length=415' Tc=5.0 min C=0.56 Runoff=0.55 cfs 660 cf
Subcatchment C5: Drainage Basin C5	Runoff Area=6,695 sf 75.59% Impervious Runoff Depth=1.02" Flow Length=176' Tc=5.6 min C=0.82 Runoff=0.47 cfs 569 cf
Subcatchment C6: Drainage Basin C6	Runoff Area=2,835 sf 100.00% Impervious Runoff Depth=1.18" Flow Length=554' Tc=5.0 min C=0.95 Runoff=0.23 cfs 279 cf
Subcatchment C7: Drainage Basin C7	Runoff Area=1,597 sf 100.00% Impervious Runoff Depth=1.18" Flow Length=531' Tc=5.0 min C=0.95 Runoff=0.13 cfs 157 cf
Subcatchment C8: Drainage Basin C8	Runoff Area=1,548 sf 100.00% Impervious Runoff Depth=1.18" Flow Length=527' Tc=5.0 min C=0.95 Runoff=0.13 cfs 152 cf
Subcatchment C9: Drainage Basin C9	Runoff Area=13,817 sf 67.75% Impervious Runoff Depth=0.96" Flow Length=709' Tc=5.0 min C=0.77 Runoff=0.92 cfs 1,103 cf

Goddard

Prepared by Phillip Lewis Engineering

HydroCAD® 10.20-5c s/n 12520 © 2023 HydroCAD Software Solutions LLC

AR - Little Rock 10-yr Duration=20 min, Inten=4.22 in/hr

Printed 3/25/2026

Time span=0.00-3.00 hrs, dt=0.01 hrs, 301 points

Runoff by Rational method, Rise/Fall=1.0/1.0 xTc

Reach routing by Stor-Ind+Trans method - Pond routing by Stor-Ind method

Subcatchment B1: Drainage Basin B1	Runoff Area=74,767 sf 0.81% Impervious Runoff Depth=0.75" Flow Length=442' Tc=18.5 min C=0.53 Runoff=3.87 cfs 4,644 cf
Subcatchment B2: Drainage Basin B2	Runoff Area=6,762 sf 2.47% Impervious Runoff Depth=0.73" Flow Length=61' Tc=5.8 min C=0.52 Runoff=0.34 cfs 412 cf
Subcatchment B3: Drainage Basin B3	Runoff Area=33,289 sf 43.74% Impervious Runoff Depth=0.98" Flow Length=610' Tc=15.4 min C=0.70 Runoff=2.28 cfs 2,730 cf
Subcatchment B4: Drainage Basin B4	Runoff Area=19,493 sf 74.78% Impervious Runoff Depth=1.18" Flow Length=249' Tc=5.0 min C=0.84 Runoff=1.60 cfs 1,918 cf
Subcatchment B5: Drainage Basin B5	Runoff Area=9,275 sf 100.00% Impervious Runoff Depth=1.34" Tc=5.0 min C=0.95 Runoff=0.86 cfs 1,032 cf
Subcatchment B6: Drainage Basin B6	Runoff Area=1,887 sf 100.00% Impervious Runoff Depth=1.34" Flow Length=507' Tc=5.0 min C=0.95 Runoff=0.18 cfs 210 cf
Subcatchment B7: Drainage Basin B7	Runoff Area=22,169 sf 29.72% Impervious Runoff Depth=0.90" Flow Length=182' Tc=10.0 min C=0.64 Runoff=1.39 cfs 1,662 cf
Subcatchment B8: Drainage Basin B8	Runoff Area=14,440 sf 44.72% Impervious Runoff Depth=1.00" Flow Length=127' Tc=14.0 min C=0.71 Runoff=1.00 cfs 1,201 cf
Subcatchment C1: Drainage Basin C1	Runoff Area=20,337 sf 69.83% Impervious Runoff Depth=1.10" Flow Length=134' Tc=5.2 min C=0.78 Runoff=1.55 cfs 1,858 cf
Subcatchment C10: Drainage Basin C10	Runoff Area=5,408 sf 77.35% Impervious Runoff Depth=1.17" Flow Length=582' Tc=5.0 min C=0.83 Runoff=0.44 cfs 526 cf
Subcatchment C11: Drainage Basin C11	Runoff Area=6,183 sf 53.49% Impervious Runoff Depth=0.97" Flow Length=633' Tc=5.0 min C=0.69 Runoff=0.42 cfs 500 cf
Subcatchment C12: Drainage Basin C12	Runoff Area=25,658 sf 71.87% Impervious Runoff Depth=1.12" Flow Length=880' Tc=5.0 min C=0.80 Runoff=2.00 cfs 2,405 cf
Subcatchment C13: Drainage Basin C13	Runoff Area=7,946 sf 80.39% Impervious Runoff Depth=1.18" Flow Length=777' Tc=5.0 min C=0.84 Runoff=0.65 cfs 782 cf
Subcatchment C14: Drainage Basin C14	Runoff Area=22,025 sf 72.18% Impervious Runoff Depth=1.12" Flow Length=492' Tc=15.9 min C=0.80 Runoff=1.72 cfs 2,065 cf
Subcatchment C15: Drainage Basin C15	Runoff Area=13,450 sf 100.00% Impervious Runoff Depth=1.34" Flow Length=415' Tc=5.0 min C=0.95 Runoff=1.25 cfs 1,497 cf
Subcatchment C16: Drainage Basin C16	Runoff Area=22,077 sf 29.95% Impervious Runoff Depth=0.79" Flow Length=714' Tc=5.0 min C=0.56 Runoff=1.21 cfs 1,448 cf

Goddard

Prepared by Phillip Lewis Engineering

HydroCAD® 10.20-5c s/n 12520 © 2023 HydroCAD Software Solutions LLC

AR - Little Rock 10-yr Duration=20 min, Inten=4.22 in/hr

Printed 3/25/2026

Subcatchment C17: Drainage Basin C17	Runoff Area=56,749 sf 0.00% Impervious Runoff Depth=0.56" Flow Length=298' Tc=9.6 min C=0.40 Runoff=2.22 cfs 2,660 cf
Subcatchment C18: Drainage Basin C18	Runoff Area=22,785 sf 43.77% Impervious Runoff Depth=0.90" Flow Length=520' Tc=5.0 min C=0.64 Runoff=1.42 cfs 1,708 cf
Subcatchment C19: Drainage Basin C19	Runoff Area=18,009 sf 0.00% Impervious Runoff Depth=0.56" Flow Length=393' Tc=7.2 min C=0.40 Runoff=0.70 cfs 844 cf
Subcatchment C2: Drainage Basin C2	Runoff Area=34,339 sf 66.87% Impervious Runoff Depth=1.08" Flow Length=695' Tc=5.0 min C=0.77 Runoff=2.58 cfs 3,098 cf
Subcatchment C20: Drainage Basin C20	Runoff Area=30,789 sf 0.00% Impervious Runoff Depth=0.56" Flow Length=205' Tc=7.9 min C=0.40 Runoff=1.20 cfs 1,443 cf
Subcatchment C3: Drainage Basin C3	Runoff Area=3,480 sf 100.00% Impervious Runoff Depth=1.34" Flow Length=612' Tc=5.0 min C=0.95 Runoff=0.32 cfs 387 cf
Subcatchment C4: Drainage Basin C4	Runoff Area=11,375 sf 28.53% Impervious Runoff Depth=0.79" Flow Length=415' Tc=5.0 min C=0.56 Runoff=0.62 cfs 746 cf
Subcatchment C5: Drainage Basin C5	Runoff Area=6,695 sf 75.59% Impervious Runoff Depth=1.15" Flow Length=176' Tc=5.6 min C=0.82 Runoff=0.54 cfs 643 cf
Subcatchment C6: Drainage Basin C6	Runoff Area=2,835 sf 100.00% Impervious Runoff Depth=1.34" Flow Length=554' Tc=5.0 min C=0.95 Runoff=0.26 cfs 316 cf
Subcatchment C7: Drainage Basin C7	Runoff Area=1,597 sf 100.00% Impervious Runoff Depth=1.34" Flow Length=531' Tc=5.0 min C=0.95 Runoff=0.15 cfs 178 cf
Subcatchment C8: Drainage Basin C8	Runoff Area=1,548 sf 100.00% Impervious Runoff Depth=1.34" Flow Length=527' Tc=5.0 min C=0.95 Runoff=0.14 cfs 172 cf
Subcatchment C9: Drainage Basin C9	Runoff Area=13,817 sf 67.75% Impervious Runoff Depth=1.08" Flow Length=709' Tc=5.0 min C=0.77 Runoff=1.04 cfs 1,246 cf

Goddard

Prepared by Phillip Lewis Engineering

HydroCAD® 10.20-5c s/n 12520 © 2023 HydroCAD Software Solutions LLC

AR - Little Rock 25-yr Duration=20 min, Inten=4.84 in/hr

Printed 3/25/2026

Time span=0.00-3.00 hrs, dt=0.01 hrs, 301 points

Runoff by Rational method, Rise/Fall=1.0/1.0 xTc

Reach routing by Stor-Ind+Trans method - Pond routing by Stor-Ind method

Subcatchment B1: Drainage Basin B1	Runoff Area=74,767 sf 0.81% Impervious Runoff Depth=0.85" Flow Length=442' Tc=18.5 min C=0.53 Runoff=4.44 cfs 5,324 cf
Subcatchment B2: Drainage Basin B2	Runoff Area=6,762 sf 2.47% Impervious Runoff Depth=0.84" Flow Length=61' Tc=5.8 min C=0.52 Runoff=0.39 cfs 472 cf
Subcatchment B3: Drainage Basin B3	Runoff Area=33,289 sf 43.74% Impervious Runoff Depth=1.13" Flow Length=610' Tc=15.4 min C=0.70 Runoff=2.61 cfs 3,130 cf
Subcatchment B4: Drainage Basin B4	Runoff Area=19,493 sf 74.78% Impervious Runoff Depth=1.35" Flow Length=249' Tc=5.0 min C=0.84 Runoff=1.83 cfs 2,199 cf
Subcatchment B5: Drainage Basin B5	Runoff Area=9,275 sf 100.00% Impervious Runoff Depth=1.53" Tc=5.0 min C=0.95 Runoff=0.99 cfs 1,184 cf
Subcatchment B6: Drainage Basin B6	Runoff Area=1,887 sf 100.00% Impervious Runoff Depth=1.53" Flow Length=507' Tc=5.0 min C=0.95 Runoff=0.20 cfs 241 cf
Subcatchment B7: Drainage Basin B7	Runoff Area=22,169 sf 29.72% Impervious Runoff Depth=1.03" Flow Length=182' Tc=10.0 min C=0.64 Runoff=1.59 cfs 1,906 cf
Subcatchment B8: Drainage Basin B8	Runoff Area=14,440 sf 44.72% Impervious Runoff Depth=1.14" Flow Length=127' Tc=14.0 min C=0.71 Runoff=1.15 cfs 1,377 cf
Subcatchment C1: Drainage Basin C1	Runoff Area=20,337 sf 69.83% Impervious Runoff Depth=1.26" Flow Length=134' Tc=5.2 min C=0.78 Runoff=1.78 cfs 2,130 cf
Subcatchment C10: Drainage Basin C10	Runoff Area=5,408 sf 77.35% Impervious Runoff Depth=1.34" Flow Length=582' Tc=5.0 min C=0.83 Runoff=0.50 cfs 603 cf
Subcatchment C11: Drainage Basin C11	Runoff Area=6,183 sf 53.49% Impervious Runoff Depth=1.11" Flow Length=633' Tc=5.0 min C=0.69 Runoff=0.48 cfs 573 cf
Subcatchment C12: Drainage Basin C12	Runoff Area=25,658 sf 71.87% Impervious Runoff Depth=1.29" Flow Length=880' Tc=5.0 min C=0.80 Runoff=2.30 cfs 2,757 cf
Subcatchment C13: Drainage Basin C13	Runoff Area=7,946 sf 80.39% Impervious Runoff Depth=1.35" Flow Length=777' Tc=5.0 min C=0.84 Runoff=0.75 cfs 897 cf
Subcatchment C14: Drainage Basin C14	Runoff Area=22,025 sf 72.18% Impervious Runoff Depth=1.29" Flow Length=492' Tc=15.9 min C=0.80 Runoff=1.97 cfs 2,367 cf
Subcatchment C15: Drainage Basin C15	Runoff Area=13,450 sf 100.00% Impervious Runoff Depth=1.53" Flow Length=415' Tc=5.0 min C=0.95 Runoff=1.43 cfs 1,716 cf
Subcatchment C16: Drainage Basin C16	Runoff Area=22,077 sf 29.95% Impervious Runoff Depth=0.90" Flow Length=714' Tc=5.0 min C=0.56 Runoff=1.38 cfs 1,661 cf

Goddard

Prepared by Phillip Lewis Engineering

HydroCAD® 10.20-5c s/n 12520 © 2023 HydroCAD Software Solutions LLC

AR - Little Rock 25-yr Duration=20 min, Inten=4.84 in/hr

Printed 3/25/2026

Subcatchment C17: Drainage Basin C17	Runoff Area=56,749 sf 0.00% Impervious Runoff Depth=0.65" Flow Length=298' Tc=9.6 min C=0.40 Runoff=2.54 cfs 3,050 cf
Subcatchment C18: Drainage Basin C18	Runoff Area=22,785 sf 43.77% Impervious Runoff Depth=1.03" Flow Length=520' Tc=5.0 min C=0.64 Runoff=1.63 cfs 1,959 cf
Subcatchment C19: Drainage Basin C19	Runoff Area=18,009 sf 0.00% Impervious Runoff Depth=0.65" Flow Length=393' Tc=7.2 min C=0.40 Runoff=0.81 cfs 968 cf
Subcatchment C2: Drainage Basin C2	Runoff Area=34,339 sf 66.87% Impervious Runoff Depth=1.24" Flow Length=695' Tc=5.0 min C=0.77 Runoff=2.96 cfs 3,552 cf
Subcatchment C20: Drainage Basin C20	Runoff Area=30,789 sf 0.00% Impervious Runoff Depth=0.64" Flow Length=205' Tc=7.9 min C=0.40 Runoff=1.38 cfs 1,655 cf
Subcatchment C3: Drainage Basin C3	Runoff Area=3,480 sf 100.00% Impervious Runoff Depth=1.53" Flow Length=612' Tc=5.0 min C=0.95 Runoff=0.37 cfs 444 cf
Subcatchment C4: Drainage Basin C4	Runoff Area=11,375 sf 28.53% Impervious Runoff Depth=0.90" Flow Length=415' Tc=5.0 min C=0.56 Runoff=0.71 cfs 856 cf
Subcatchment C5: Drainage Basin C5	Runoff Area=6,695 sf 75.59% Impervious Runoff Depth=1.32" Flow Length=176' Tc=5.6 min C=0.82 Runoff=0.61 cfs 737 cf
Subcatchment C6: Drainage Basin C6	Runoff Area=2,835 sf 100.00% Impervious Runoff Depth=1.53" Flow Length=554' Tc=5.0 min C=0.95 Runoff=0.30 cfs 362 cf
Subcatchment C7: Drainage Basin C7	Runoff Area=1,597 sf 100.00% Impervious Runoff Depth=1.53" Flow Length=531' Tc=5.0 min C=0.95 Runoff=0.17 cfs 204 cf
Subcatchment C8: Drainage Basin C8	Runoff Area=1,548 sf 100.00% Impervious Runoff Depth=1.53" Flow Length=527' Tc=5.0 min C=0.95 Runoff=0.16 cfs 198 cf
Subcatchment C9: Drainage Basin C9	Runoff Area=13,817 sf 67.75% Impervious Runoff Depth=1.24" Flow Length=709' Tc=5.0 min C=0.77 Runoff=1.19 cfs 1,429 cf

Goddard

Prepared by Phillip Lewis Engineering

HydroCAD® 10.20-5c s/n 12520 © 2023 HydroCAD Software Solutions LLC

AR - Little Rock 100-yr Duration=20 min, Inten=5.78 in/hr

Printed 3/25/2026

Time span=0.00-3.00 hrs, dt=0.01 hrs, 301 points

Runoff by Rational method, Rise/Fall=1.0/1.0 xTc

Reach routing by Stor-Ind+Trans method - Pond routing by Stor-Ind method

Subcatchment B1: Drainage Basin B1	Runoff Area=74,767 sf 0.81% Impervious Runoff Depth=1.02" Flow Length=442' Tc=18.5 min C=0.53 Runoff=5.30 cfs 6,363 cf
Subcatchment B2: Drainage Basin B2	Runoff Area=6,762 sf 2.47% Impervious Runoff Depth=1.00" Flow Length=61' Tc=5.8 min C=0.52 Runoff=0.47 cfs 564 cf
Subcatchment B3: Drainage Basin B3	Runoff Area=33,289 sf 43.74% Impervious Runoff Depth=1.35" Flow Length=610' Tc=15.4 min C=0.70 Runoff=3.12 cfs 3,741 cf
Subcatchment B4: Drainage Basin B4	Runoff Area=19,493 sf 74.78% Impervious Runoff Depth=1.62" Flow Length=249' Tc=5.0 min C=0.84 Runoff=2.19 cfs 2,628 cf
Subcatchment B5: Drainage Basin B5	Runoff Area=9,275 sf 100.00% Impervious Runoff Depth=1.83" Tc=5.0 min C=0.95 Runoff=1.18 cfs 1,414 cf
Subcatchment B6: Drainage Basin B6	Runoff Area=1,887 sf 100.00% Impervious Runoff Depth=1.83" Flow Length=507' Tc=5.0 min C=0.95 Runoff=0.24 cfs 288 cf
Subcatchment B7: Drainage Basin B7	Runoff Area=22,169 sf 29.72% Impervious Runoff Depth=1.23" Flow Length=182' Tc=10.0 min C=0.64 Runoff=1.90 cfs 2,278 cf
Subcatchment B8: Drainage Basin B8	Runoff Area=14,440 sf 44.72% Impervious Runoff Depth=1.37" Flow Length=127' Tc=14.0 min C=0.71 Runoff=1.37 cfs 1,646 cf
Subcatchment C1: Drainage Basin C1	Runoff Area=20,337 sf 69.83% Impervious Runoff Depth=1.50" Flow Length=134' Tc=5.2 min C=0.78 Runoff=2.12 cfs 2,545 cf
Subcatchment C10: Drainage Basin C10	Runoff Area=5,408 sf 77.35% Impervious Runoff Depth=1.60" Flow Length=582' Tc=5.0 min C=0.83 Runoff=0.60 cfs 721 cf
Subcatchment C11: Drainage Basin C11	Runoff Area=6,183 sf 53.49% Impervious Runoff Depth=1.33" Flow Length=633' Tc=5.0 min C=0.69 Runoff=0.57 cfs 685 cf
Subcatchment C12: Drainage Basin C12	Runoff Area=25,658 sf 71.87% Impervious Runoff Depth=1.54" Flow Length=880' Tc=5.0 min C=0.80 Runoff=2.75 cfs 3,295 cf
Subcatchment C13: Drainage Basin C13	Runoff Area=7,946 sf 80.39% Impervious Runoff Depth=1.62" Flow Length=777' Tc=5.0 min C=0.84 Runoff=0.89 cfs 1,071 cf
Subcatchment C14: Drainage Basin C14	Runoff Area=22,025 sf 72.18% Impervious Runoff Depth=1.54" Flow Length=492' Tc=15.9 min C=0.80 Runoff=2.36 cfs 2,829 cf
Subcatchment C15: Drainage Basin C15	Runoff Area=13,450 sf 100.00% Impervious Runoff Depth=1.83" Flow Length=415' Tc=5.0 min C=0.95 Runoff=1.71 cfs 2,051 cf
Subcatchment C16: Drainage Basin C16	Runoff Area=22,077 sf 29.95% Impervious Runoff Depth=1.08" Flow Length=714' Tc=5.0 min C=0.56 Runoff=1.65 cfs 1,985 cf

Goddard

Prepared by Phillip Lewis Engineering

HydroCAD® 10.20-5c s/n 12520 © 2023 HydroCAD Software Solutions LLC

AR - Little Rock 100-yr Duration=20 min, Inten=5.78 in/hr

Printed 3/25/2026

Subcatchment C17: Drainage Basin C17	Runoff Area=56,749 sf 0.00% Impervious Runoff Depth=0.77" Flow Length=298' Tc=9.6 min C=0.40 Runoff=3.04 cfs 3,645 cf
Subcatchment C18: Drainage Basin C18	Runoff Area=22,785 sf 43.77% Impervious Runoff Depth=1.23" Flow Length=520' Tc=5.0 min C=0.64 Runoff=1.95 cfs 2,341 cf
Subcatchment C19: Drainage Basin C19	Runoff Area=18,009 sf 0.00% Impervious Runoff Depth=0.77" Flow Length=393' Tc=7.2 min C=0.40 Runoff=0.96 cfs 1,157 cf
Subcatchment C2: Drainage Basin C2	Runoff Area=34,339 sf 66.87% Impervious Runoff Depth=1.48" Flow Length=695' Tc=5.0 min C=0.77 Runoff=3.54 cfs 4,244 cf
Subcatchment C20: Drainage Basin C20	Runoff Area=30,789 sf 0.00% Impervious Runoff Depth=0.77" Flow Length=205' Tc=7.9 min C=0.40 Runoff=1.65 cfs 1,978 cf
Subcatchment C3: Drainage Basin C3	Runoff Area=3,480 sf 100.00% Impervious Runoff Depth=1.83" Flow Length=612' Tc=5.0 min C=0.95 Runoff=0.44 cfs 531 cf
Subcatchment C4: Drainage Basin C4	Runoff Area=11,375 sf 28.53% Impervious Runoff Depth=1.08" Flow Length=415' Tc=5.0 min C=0.56 Runoff=0.85 cfs 1,023 cf
Subcatchment C5: Drainage Basin C5	Runoff Area=6,695 sf 75.59% Impervious Runoff Depth=1.58" Flow Length=176' Tc=5.6 min C=0.82 Runoff=0.73 cfs 881 cf
Subcatchment C6: Drainage Basin C6	Runoff Area=2,835 sf 100.00% Impervious Runoff Depth=1.83" Flow Length=554' Tc=5.0 min C=0.95 Runoff=0.36 cfs 432 cf
Subcatchment C7: Drainage Basin C7	Runoff Area=1,597 sf 100.00% Impervious Runoff Depth=1.83" Flow Length=531' Tc=5.0 min C=0.95 Runoff=0.20 cfs 244 cf
Subcatchment C8: Drainage Basin C8	Runoff Area=1,548 sf 100.00% Impervious Runoff Depth=1.83" Flow Length=527' Tc=5.0 min C=0.95 Runoff=0.20 cfs 236 cf
Subcatchment C9: Drainage Basin C9	Runoff Area=13,817 sf 67.75% Impervious Runoff Depth=1.48" Flow Length=709' Tc=5.0 min C=0.77 Runoff=1.42 cfs 1,708 cf

POST DEVELOPMENT HYDROGRAPHS

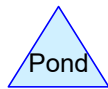
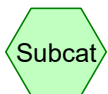
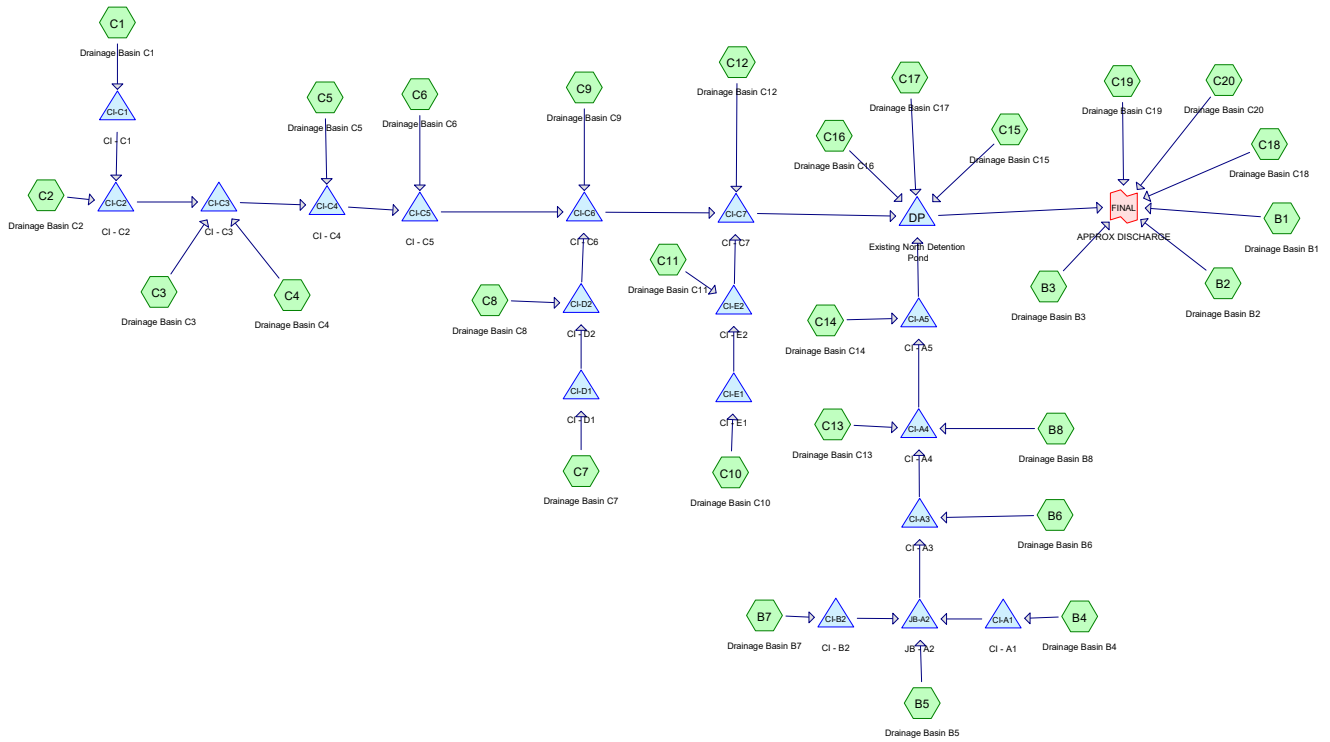

Routing Diagram for Goddard
 Prepared by Phillip Lewis Engineering, Printed 3/25/2026
 HydroCAD® 10.20-5c s/n 12520 © 2023 HydroCAD Software Solutions LLC

Goddard

Prepared by Phillip Lewis Engineering

HydroCAD® 10.20-5c s/n 12520 © 2023 HydroCAD Software Solutions LLC

AR - Little Rock 2-yr Duration=20 min, Inten=3.13 in/hr

Printed 3/25/2026

Summary for Subcatchment B1: Drainage Basin B1

Runoff = 2.87 cfs @ 0.31 hrs, Volume= 3,450 cf, Depth= 0.55"

Routed to Link FINAL : APPROX DISCHARGE

Runoff by Rational method, Rise/Fall=1.0/1.0 xTc, Time Span= 0.00-3.00 hrs, dt= 0.01 hrs

AR - Little Rock 2-yr Duration=20 min, Inten=3.13 in/hr

Area (sf)	C	Description
9,241	0.51	Sod Yard
602	0.95	Paving, Sidewalks
64,924	0.53	Undeveloped
74,767	0.53	Weighted Average
74,165		99.19% Pervious Area
602		0.81% Impervious Area

Tc (min)	Length (feet)	Slope (ft/ft)	Velocity (ft/sec)	Capacity (cfs)	Description
0.1	6	0.0180	0.86		Sheet Flow, Sheet Flow Smooth surfaces n= 0.011 P2= 4.19"
2.6	25	0.1920	0.16		Sheet Flow, Sheet Flow Grass: Bermuda n= 0.410 P2= 4.19"
11.9	75	0.0370	0.11		Sheet Flow, Sheet Flow Grass: Bermuda n= 0.410 P2= 4.19"
0.7	58	0.0370	1.35		Shallow Concentrated Flow, Concentrated Flow Short Grass Pasture Kv= 7.0 fps
1.6	141	0.0420	1.43		Shallow Concentrated Flow, Concentrated Flow Short Grass Pasture Kv= 7.0 fps
0.7	60	0.0400	1.40		Shallow Concentrated Flow, Concentrated Flow Short Grass Pasture Kv= 7.0 fps
0.9	77	0.0420	1.43		Shallow Concentrated Flow, Concentrated Flow Short Grass Pasture Kv= 7.0 fps
18.5	442	Total			

Subcatchment B1: Drainage Basin B1

Hydrograph

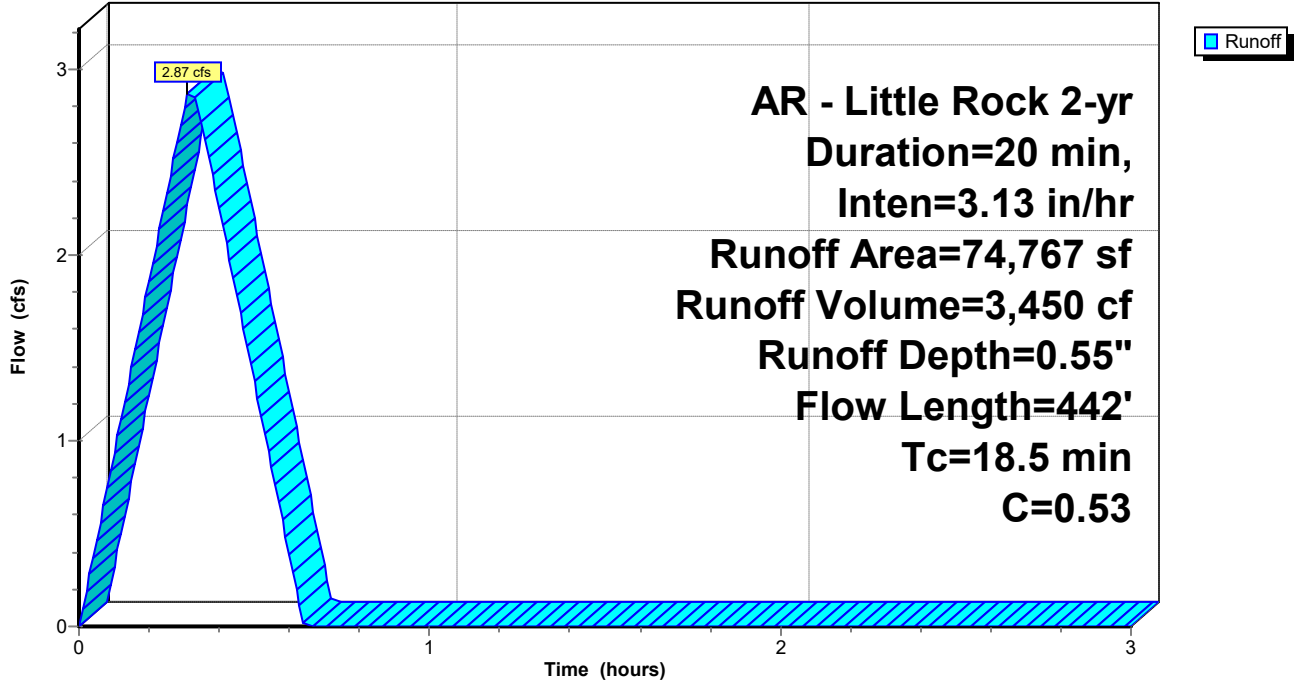

Goddard

Prepared by Phillip Lewis Engineering

HydroCAD® 10.20-5c s/n 12520 © 2023 HydroCAD Software Solutions LLC

AR - Little Rock 2-yr Duration=20 min, Inten=3.13 in/hr

Printed 3/25/2026

Summary for Subcatchment B2: Drainage Basin B2

Runoff = 0.26 cfs @ 0.10 hrs, Volume= 306 cf, Depth= 0.54"
 Routed to Link FINAL : APPROX DISCHARGE

Runoff by Rational method, Rise/Fall=1.0/1.0 xTc, Time Span= 0.00-3.00 hrs, dt= 0.01 hrs
 AR - Little Rock 2-yr Duration=20 min, Inten=3.13 in/hr

Area (sf)	C	Description
6,595	0.51	Sod Yard
167	0.95	Paving, Sidewalks
6,762	0.52	Weighted Average
6,595		97.53% Pervious Area
167		2.47% Impervious Area

Tc (min)	Length (feet)	Slope (ft/ft)	Velocity (ft/sec)	Capacity (cfs)	Description
0.1	6	0.0180	0.86		Sheet Flow, Sheet Flow Smooth surfaces n= 0.011 P2= 4.19"
5.7	55	0.1240	0.16		Sheet Flow, Sheet Flow Grass: Bermuda n= 0.410 P2= 4.19"
5.8	61	Total			

Subcatchment B2: Drainage Basin B2

Hydrograph

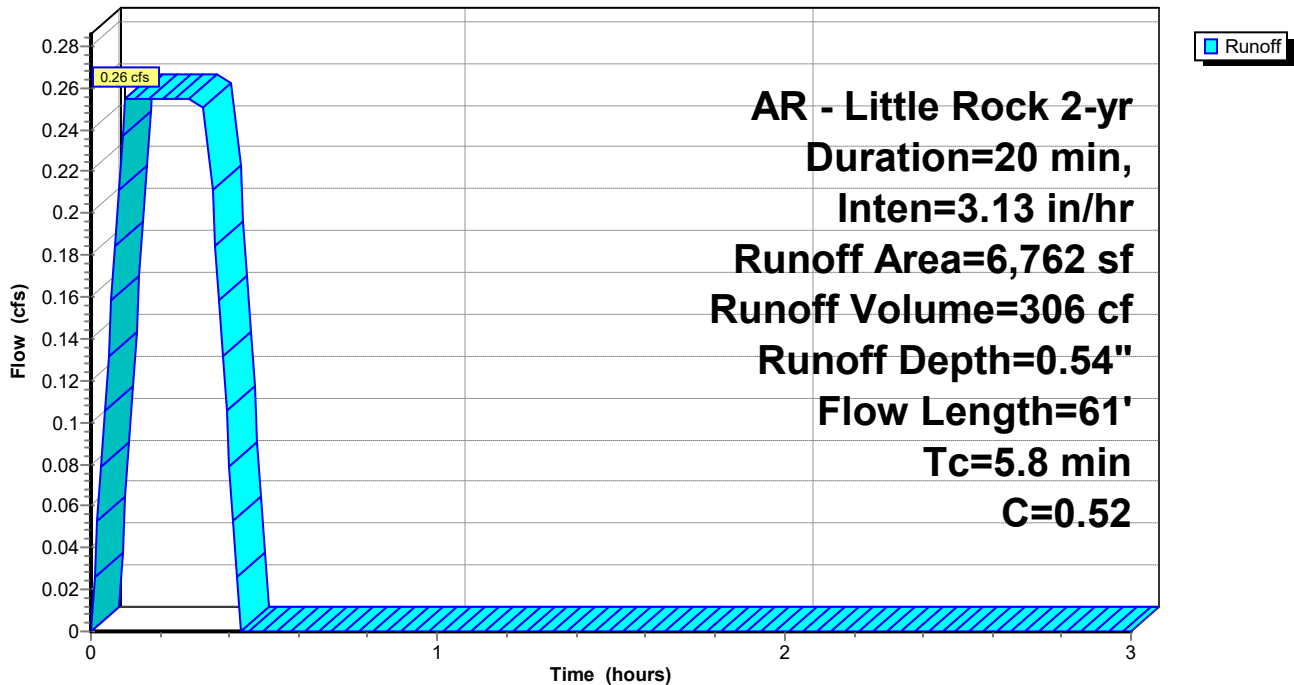

Goddard

Prepared by Phillip Lewis Engineering

HydroCAD® 10.20-5c s/n 12520 © 2023 HydroCAD Software Solutions LLC

AR - Little Rock 2-yr Duration=20 min, Inten=3.13 in/hr

Printed 3/25/2026

Summary for Subcatchment B3: Drainage Basin B3

Runoff = 1.69 cfs @ 0.26 hrs, Volume= 2,028 cf, Depth= 0.73"
 Routed to Link FINAL : APPROX DISCHARGE

Runoff by Rational method, Rise/Fall=1.0/1.0 xTc, Time Span= 0.00-3.00 hrs, dt= 0.01 hrs
 AR - Little Rock 2-yr Duration=20 min, Inten=3.13 in/hr

Area (sf)	C	Description
18,730	0.51	Sod Yard
14,559	0.95	Paving, Sidewalks
33,289	0.70	Weighted Average
18,730		56.26% Pervious Area
14,559		43.74% Impervious Area

Tc (min)	Length (feet)	Slope (ft/ft)	Velocity (ft/sec)	Capacity (cfs)	Description
4.9	47	0.1300	0.16		Sheet Flow, Sheet Flow Grass: Bermuda n= 0.410 P2= 4.19"
6.9	53	0.0730	0.13		Sheet Flow, Sheet Flow Grass: Bermuda n= 0.410 P2= 4.19"
0.0	11	0.0940	4.60		Shallow Concentrated Flow, Concentrated Flow Grassed Waterway Kv= 15.0 fps
0.4	53	0.0120	2.22		Shallow Concentrated Flow, Concentrated Flow Paved Kv= 20.3 fps
0.5	59	0.0100	2.03		Shallow Concentrated Flow, Concentrated Flow Paved Kv= 20.3 fps
0.5	47	0.0070	1.70		Shallow Concentrated Flow, Concentrated Flow Paved Kv= 20.3 fps
0.5	56	0.0070	1.70		Shallow Concentrated Flow, Concentrated Flow Paved Kv= 20.3 fps
0.2	38	0.0160	2.57		Shallow Concentrated Flow, Concentrated Flow Paved Kv= 20.3 fps
0.2	30	0.0190	2.80		Shallow Concentrated Flow, Concentrated Flow Paved Kv= 20.3 fps
1.3	216	0.0190	2.80		Shallow Concentrated Flow, Concentrated Flow Paved Kv= 20.3 fps
15.4	610	Total			

Subcatchment B3: Drainage Basin B3

Hydrograph

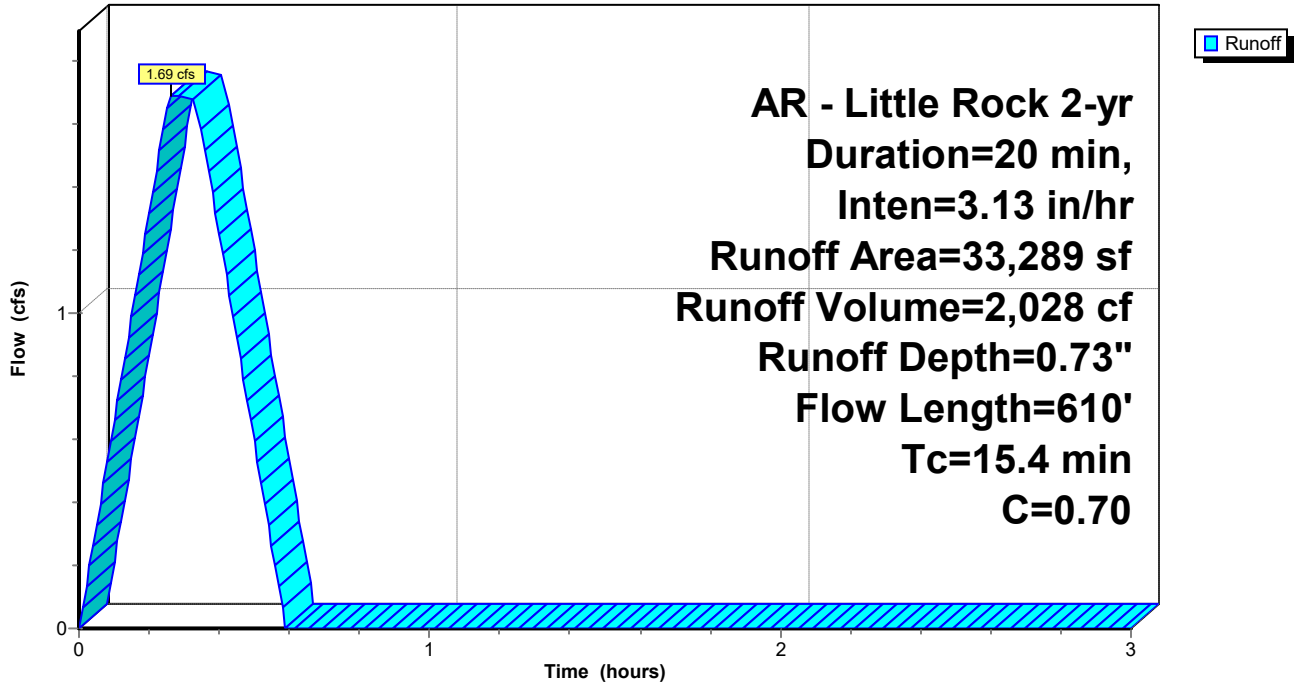

Summary for Subcatchment B4: Drainage Basin B4

Runoff = 1.19 cfs @ 0.09 hrs, Volume= 1,425 cf, Depth= 0.88"
 Routed to Pond CI-A1 : CI - A1

Runoff by Rational method, Rise/Fall=1.0/1.0 xTc, Time Span= 0.00-3.00 hrs, dt= 0.01 hrs
 AR - Little Rock 2-yr Duration=20 min, Inten=3.13 in/hr

Area (sf)	C	Description
4,916	0.51	Sod Yard
14,577	0.95	Paving, Sidewalks
19,493	0.84	Weighted Average
4,916		25.22% Pervious Area
14,577		74.78% Impervious Area

Tc (min)	Length (feet)	Slope (ft/ft)	Velocity (ft/sec)	Capacity (cfs)	Description
0.4	31	0.0230	1.32		Sheet Flow, Sheet Flow Smooth surfaces n= 0.011 P2= 4.19"
0.2	18	0.0250	1.22		Sheet Flow, Sheet Flow Smooth surfaces n= 0.011 P2= 4.19"
0.3	28	0.0450	1.69		Sheet Flow, Sheet Flow Smooth surfaces n= 0.011 P2= 4.19"
0.4	72	0.0250	3.21		Shallow Concentrated Flow, Concentrated Flow Paved Kv= 20.3 fps
0.1	18	0.0170	2.65		Shallow Concentrated Flow, Concentrated Flow Paved Kv= 20.3 fps
0.3	51	0.0170	2.65		Shallow Concentrated Flow, Concentrated Flow Paved Kv= 20.3 fps
0.1	16	0.0170	2.65		Shallow Concentrated Flow, Concentrated Flow Paved Kv= 20.3 fps
0.0	8	0.0430	4.21		Shallow Concentrated Flow, Concentrated Flow Paved Kv= 20.3 fps
0.0	7	0.0580	4.89		Shallow Concentrated Flow, Concentrated Flow Paved Kv= 20.3 fps
3.2					Direct Entry, Overland Concentrated Flow (Min)
5.0	249	Total			

Subcatchment B4: Drainage Basin B4

Hydrograph

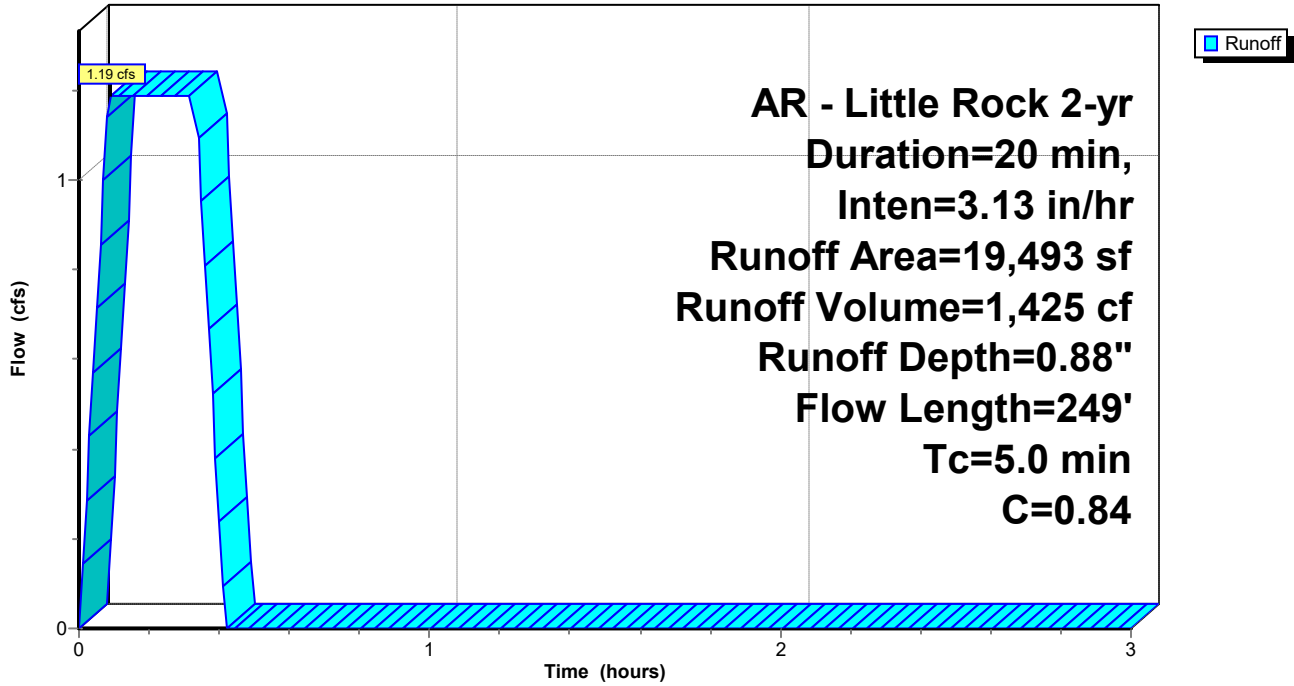

Summary for Subcatchment B5: Drainage Basin B5

Runoff = 0.64 cfs @ 0.09 hrs, Volume= 767 cf, Depth= 0.99"
 Routed to Pond JB-A2 : JB - A2

Runoff by Rational method, Rise/Fall=1.0/1.0 xTc, Time Span= 0.00-3.00 hrs, dt= 0.01 hrs
 AR - Little Rock 2-yr Duration=20 min, Inten=3.13 in/hr

Area (sf)	C	Description
9,275	0.95	Roof
9,275		100.00% Impervious Area

Tc (min)	Length (feet)	Slope (ft/ft)	Velocity (ft/sec)	Capacity (cfs)	Description
5.0					Direct Entry, Concentrated Flow (Min)

Subcatchment B5: Drainage Basin B5

Hydrograph

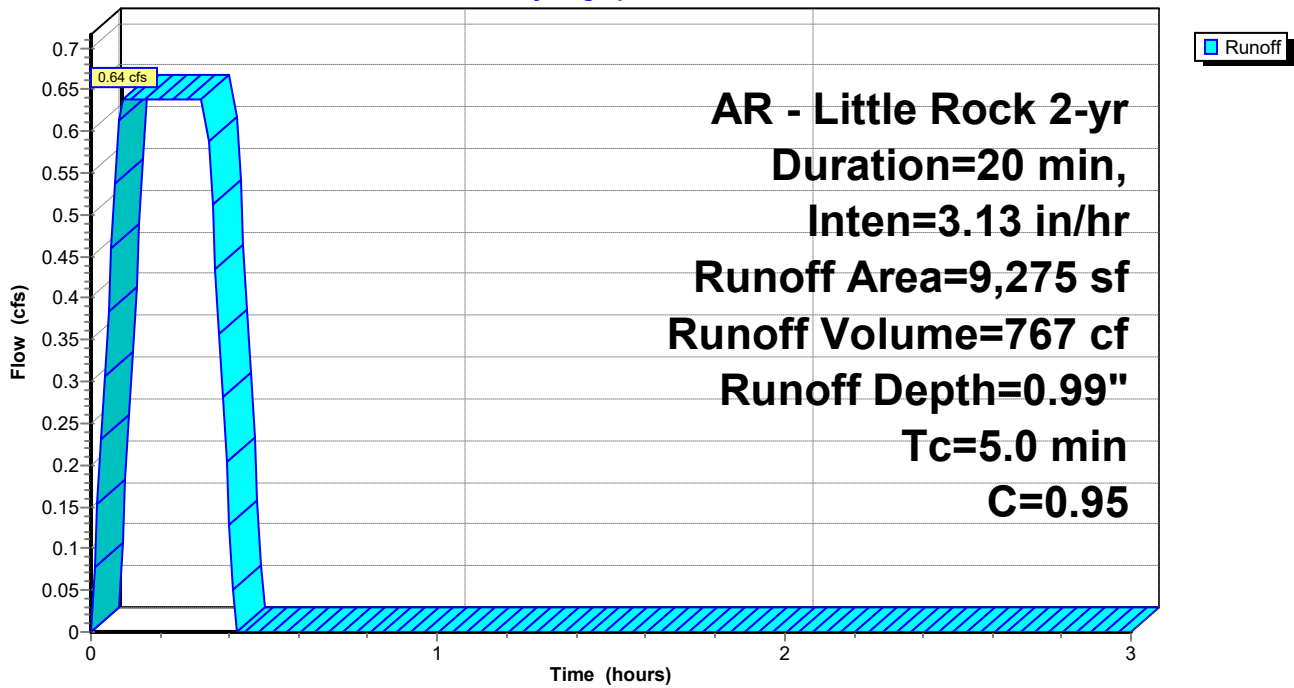

Goddard

Prepared by Phillip Lewis Engineering

HydroCAD® 10.20-5c s/n 12520 © 2023 HydroCAD Software Solutions LLC

AR - Little Rock 2-yr Duration=20 min, Inten=3.13 in/hr

Printed 3/25/2026

Summary for Subcatchment B6: Drainage Basin B6

Runoff = 0.13 cfs @ 0.09 hrs, Volume= 156 cf, Depth= 0.99"
 Routed to Pond CI-A3 : CI - A3

Runoff by Rational method, Rise/Fall=1.0/1.0 xTc, Time Span= 0.00-3.00 hrs, dt= 0.01 hrs
 AR - Little Rock 2-yr Duration=20 min, Inten=3.13 in/hr

Area (sf)	C	Description
0	0.51	Sod Yard
1,887	0.95	Paving, Sidewalks
1,887	0.95	Weighted Average
1,887		100.00% Impervious Area

Tc (min)	Length (feet)	Slope (ft/ft)	Velocity (ft/sec)	Capacity (cfs)	Description
0.4	31	0.0230	1.32		Sheet Flow, Sheet Flow Smooth surfaces n= 0.011 P2= 4.19"
0.2	18	0.0250	1.22		Sheet Flow, Sheet Flow Smooth surfaces n= 0.011 P2= 4.19"
0.4	30	0.0240	1.33		Sheet Flow, Sheet Flow Smooth surfaces n= 0.011 P2= 4.19"
0.0	13	0.0860	5.95		Shallow Concentrated Flow, Concentrated Flow Paved Kv= 20.3 fps
4.0	415		1.73		Direct Entry, Overland Concentrated Flow (Min)
5.0	507	Total			

Subcatchment B6: Drainage Basin B6

Hydrograph

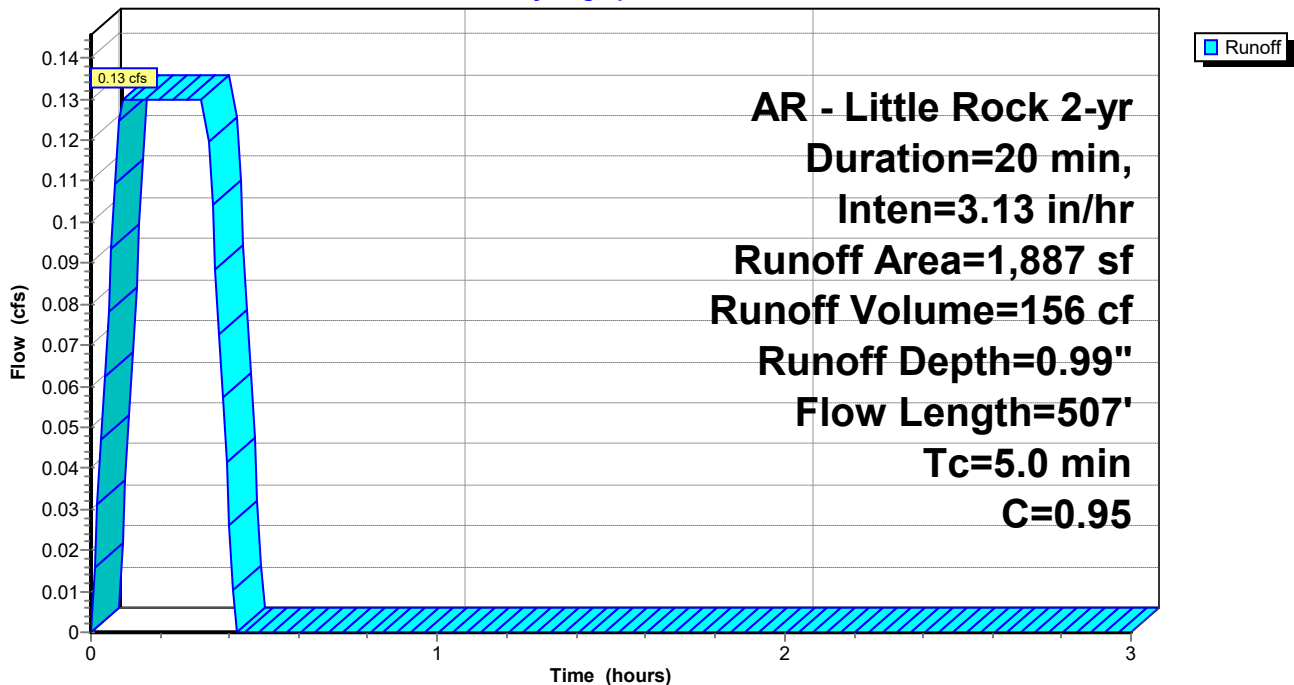

Goddard

Prepared by Phillip Lewis Engineering

HydroCAD® 10.20-5c s/n 12520 © 2023 HydroCAD Software Solutions LLC

AR - Little Rock 2-yr Duration=20 min, Inten=3.13 in/hr

Printed 3/25/2026

Summary for Subcatchment B7: Drainage Basin B7

Runoff = 1.03 cfs @ 0.17 hrs, Volume= 1,235 cf, Depth= 0.67"
 Routed to Pond CI-B2 : CI - B2

Runoff by Rational method, Rise/Fall=1.0/1.0 xTc, Time Span= 0.00-3.00 hrs, dt= 0.01 hrs
 AR - Little Rock 2-yr Duration=20 min, Inten=3.13 in/hr

Area (sf)	C	Description
15,580	0.51	Sod Yard
6,589	0.95	Paving, Sidewalks
22,169	0.64	Weighted Average
15,580		70.28% Pervious Area
6,589		29.72% Impervious Area

Tc (min)	Length (feet)	Slope (ft/ft)	Velocity (ft/sec)	Capacity (cfs)	Description
0.2	10	0.0150	0.89		Sheet Flow, Sheet Flow Smooth surfaces n= 0.011 P2= 4.19"
9.1	93	0.0150	0.17		Sheet Flow, Sheet Flow Grass: Short n= 0.150 P2= 4.19"
0.4	40	0.0110	1.57		Shallow Concentrated Flow, Concentrated Flow Grassed Waterway Kv= 15.0 fps
0.3	33	0.0190	2.07		Shallow Concentrated Flow, Concentrated Flow Grassed Waterway Kv= 15.0 fps
0.0	6	0.0180	2.72		Shallow Concentrated Flow, Concentrated Flow Paved Kv= 20.3 fps
10.0	182	Total			

Subcatchment B7: Drainage Basin B7

Hydrograph

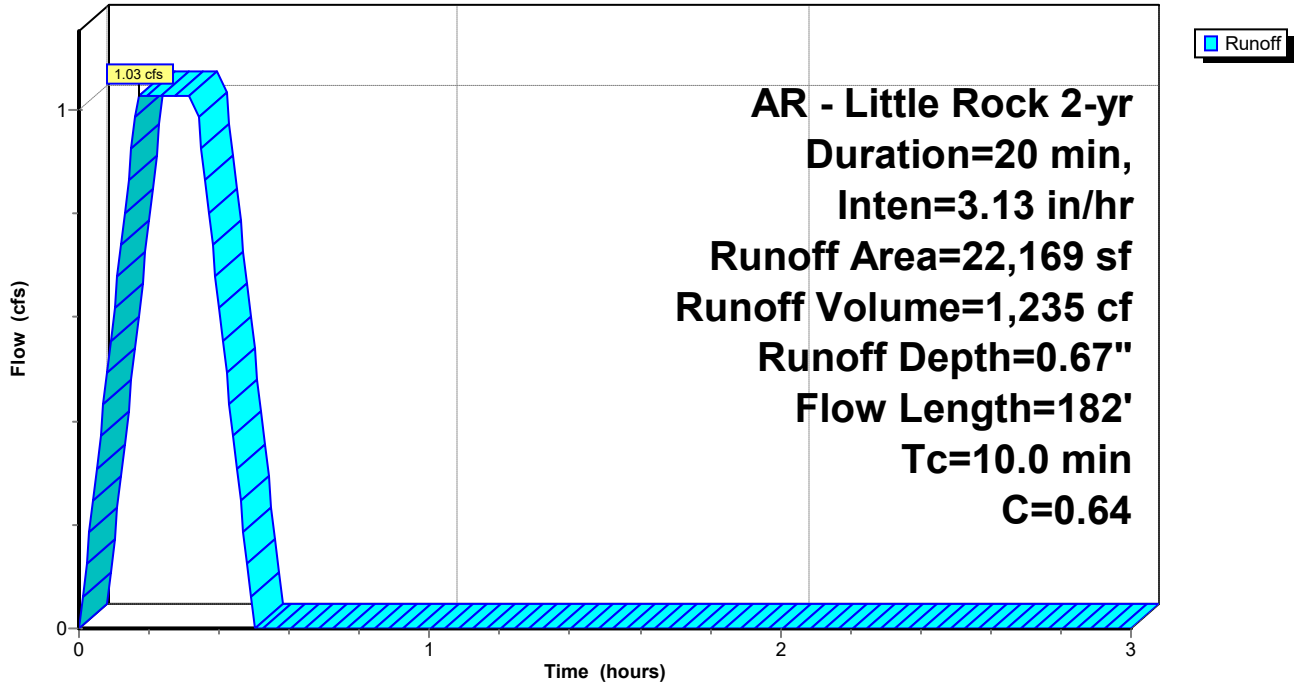

Goddard

Prepared by Phillip Lewis Engineering

HydroCAD® 10.20-5c s/n 12520 © 2023 HydroCAD Software Solutions LLC

AR - Little Rock 2-yr Duration=20 min, Inten=3.13 in/hr

Printed 3/25/2026

Summary for Subcatchment B8: Drainage Basin B8

Runoff = 0.74 cfs @ 0.24 hrs, Volume= 892 cf, Depth= 0.74"
 Routed to Pond CI-A4 : CI - A4

Runoff by Rational method, Rise/Fall=1.0/1.0 xTc, Time Span= 0.00-3.00 hrs, dt= 0.01 hrs
 AR - Little Rock 2-yr Duration=20 min, Inten=3.13 in/hr

Area (sf)	C	Description
7,982	0.51	Sod Yard
6,458	0.95	Paving, Sidewalks
14,440	0.71	Weighted Average
7,982		55.28% Pervious Area
6,458		44.72% Impervious Area

Tc (min)	Length (feet)	Slope (ft/ft)	Velocity (ft/sec)	Capacity (cfs)	Description
10.4	79	0.0570	0.13		Sheet Flow, Sheet Flow Grass: Bermuda n= 0.410 P2= 4.19"
3.5	21	0.0620	0.10		Sheet Flow, Sheet Flow Grass: Bermuda n= 0.410 P2= 4.19"
0.0	9	0.0620	3.73		Shallow Concentrated Flow, Concentrated Flow Grassed Waterway Kv= 15.0 fps
0.1	18	0.1080	4.93		Shallow Concentrated Flow, Concentrated Flow Grassed Waterway Kv= 15.0 fps
14.0	127	Total			

Subcatchment B8: Drainage Basin B8

Hydrograph

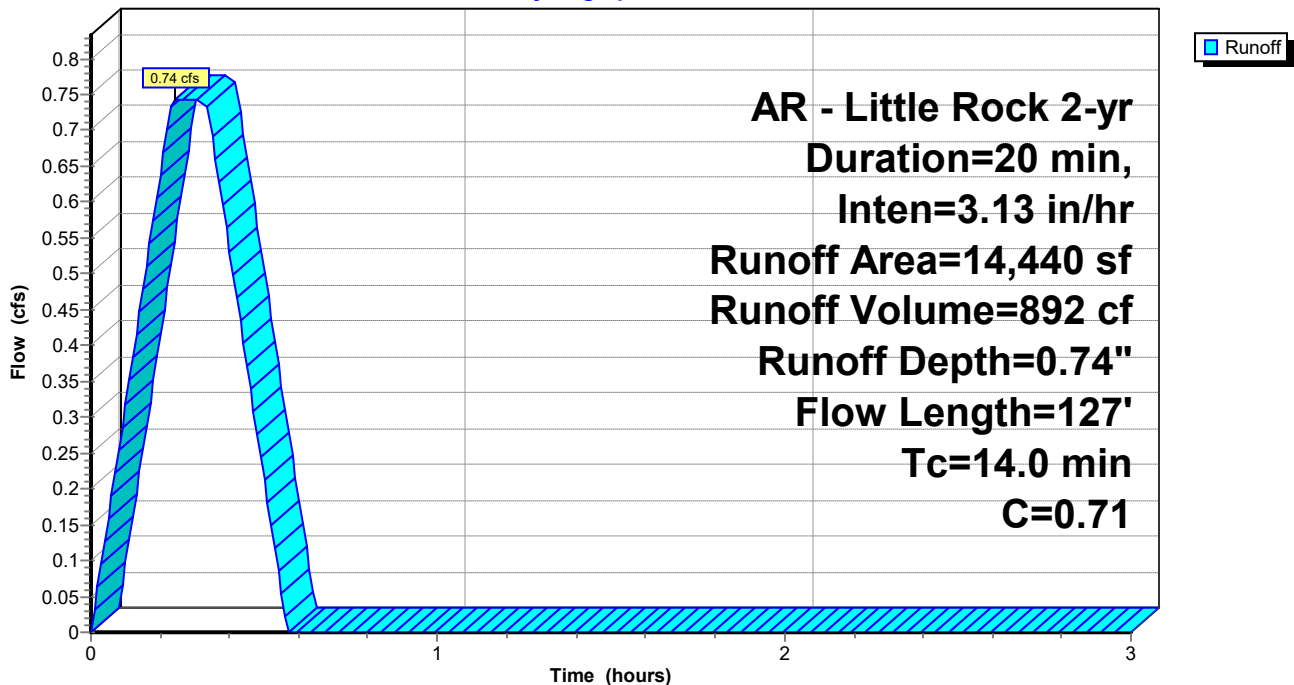

Goddard

Prepared by Phillip Lewis Engineering

HydroCAD® 10.20-5c s/n 12520 © 2023 HydroCAD Software Solutions LLC

AR - Little Rock 2-yr Duration=20 min, Inten=3.13 in/hr

Printed 3/25/2026

Summary for Subcatchment C1: Drainage Basin C1

Runoff = 1.15 cfs @ 0.09 hrs, Volume= 1,380 cf, Depth= 0.81"
 Routed to Pond CI-C1 : CI - C1

Runoff by Rational method, Rise/Fall=1.0/1.0 xTc, Time Span= 0.00-3.00 hrs, dt= 0.01 hrs
 AR - Little Rock 2-yr Duration=20 min, Inten=3.13 in/hr

Area (sf)	C	Description
6,135	0.40	Sod Yard
14,202	0.95	Paving, Sidewalks
20,337	0.78	Weighted Average
6,135		30.17% Pervious Area
14,202		69.83% Impervious Area

Tc (min)	Length (feet)	Slope (ft/ft)	Velocity (ft/sec)	Capacity (cfs)	Description
4.8	32	0.0660	0.11		Sheet Flow, Sheet Flow Grass: Bermuda n= 0.410 P2= 4.19"
0.4	102	0.0470	4.40		Shallow Concentrated Flow, Concentrated Flow Paved Kv= 20.3 fps
5.2	134	Total			

Subcatchment C1: Drainage Basin C1

Hydrograph

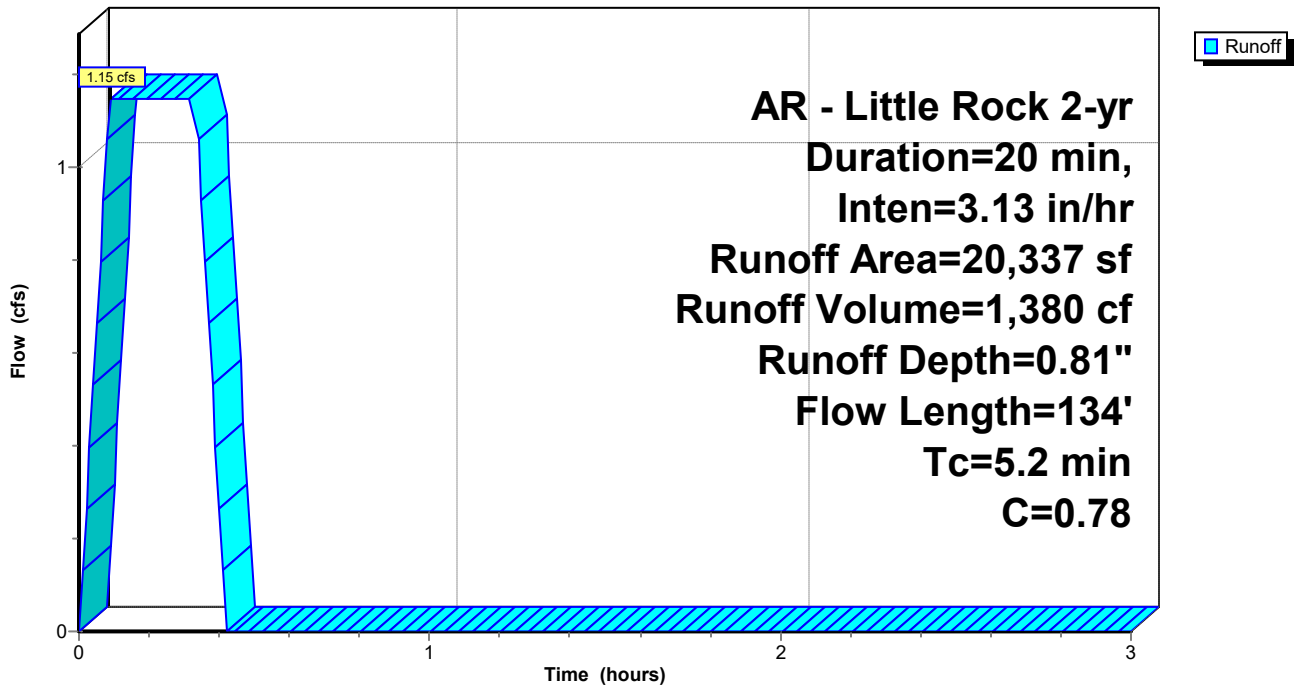

Goddard

Prepared by Phillip Lewis Engineering

HydroCAD® 10.20-5c s/n 12520 © 2023 HydroCAD Software Solutions LLC

AR - Little Rock 2-yr Duration=20 min, Inten=3.13 in/hr

Printed 3/25/2026

Summary for Subcatchment C10: Drainage Basin C10

Runoff = 0.33 cfs @ 0.09 hrs, Volume= 391 cf, Depth= 0.87"
 Routed to Pond CI-E1 : CI - E1

Runoff by Rational method, Rise/Fall=1.0/1.0 xTc, Time Span= 0.00-3.00 hrs, dt= 0.01 hrs
 AR - Little Rock 2-yr Duration=20 min, Inten=3.13 in/hr

Area (sf)	C	Description
1,225	0.40	Sod Yard
4,183	0.95	Paving, Sidewalks
5,408	0.83	Weighted Average
1,225		22.65% Pervious Area
4,183		77.35% Impervious Area

Tc (min)	Length (feet)	Slope (ft/ft)	Velocity (ft/sec)	Capacity (cfs)	Description
0.3	18	0.0200	1.12		Sheet Flow, Sheet Flow Smooth surfaces n= 0.011 P2= 4.19"
0.2	29	0.0210	2.94		Shallow Concentrated Flow, Concentrated Flow Paved Kv= 20.3 fps
0.1	23	0.0320	3.63		Shallow Concentrated Flow, Concentrated Flow Paved Kv= 20.3 fps
0.2	36	0.0320	3.63		Shallow Concentrated Flow, Concentrated Flow Paved Kv= 20.3 fps
0.2	48	0.0330	3.69		Shallow Concentrated Flow, Concentrated Flow Paved Kv= 20.3 fps
0.1	13	0.0350	3.80		Shallow Concentrated Flow, Concentrated Flow Paved Kv= 20.3 fps
3.9	415		1.77		Direct Entry, Concentrated Flow (Min)
5.0	582	Total			

Subcatchment C10: Drainage Basin C10

Hydrograph

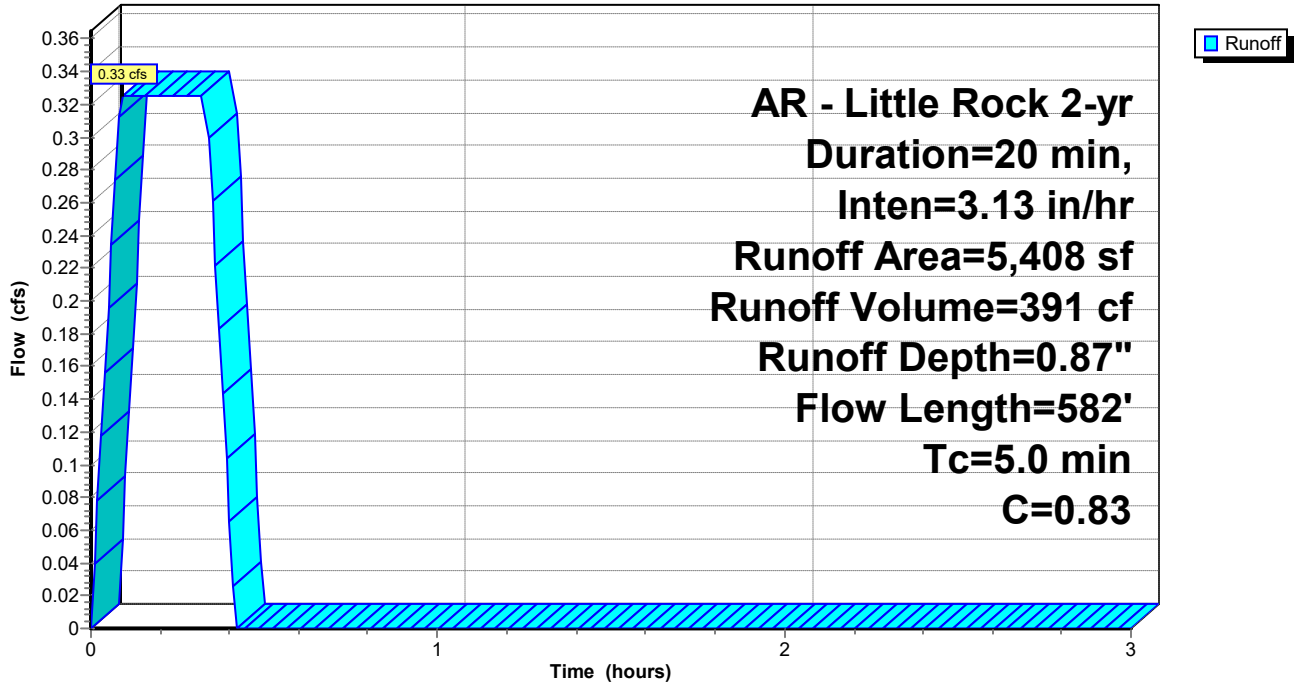

Goddard

Prepared by Phillip Lewis Engineering

HydroCAD® 10.20-5c s/n 12520 © 2023 HydroCAD Software Solutions LLC

AR - Little Rock 2-yr Duration=20 min, Inten=3.13 in/hr

Printed 3/25/2026

Summary for Subcatchment C11: Drainage Basin C11

Runoff = 0.31 cfs @ 0.09 hrs, Volume= 371 cf, Depth= 0.72"
 Routed to Pond CI-E2 : CI - E2

Runoff by Rational method, Rise/Fall=1.0/1.0 xTc, Time Span= 0.00-3.00 hrs, dt= 0.01 hrs
 AR - Little Rock 2-yr Duration=20 min, Inten=3.13 in/hr

Area (sf)	C	Description
2,876	0.40	Sod Yard
3,307	0.95	Paving, Sidewalks
6,183	0.69	Weighted Average
2,876		46.51% Pervious Area
3,307		53.49% Impervious Area

Tc (min)	Length (feet)	Slope (ft/ft)	Velocity (ft/sec)	Capacity (cfs)	Description
0.3	25	0.0200	1.19		Sheet Flow, Sheet Flow Smooth surfaces n= 0.011 P2= 4.19"
0.1	33	0.0620	5.05		Shallow Concentrated Flow, Concentrated Flow Paved Kv= 20.3 fps
0.1	29	0.0540	4.72		Shallow Concentrated Flow, Concentrated Flow Paved Kv= 20.3 fps
0.2	47	0.0410	4.11		Shallow Concentrated Flow, Concentrated Flow Paved Kv= 20.3 fps
0.2	47	0.0390	4.01		Shallow Concentrated Flow, Concentrated Flow Paved Kv= 20.3 fps
0.1	37	0.0420	4.16		Shallow Concentrated Flow, Concentrated Flow Paved Kv= 20.3 fps
4.0	415		1.73		Direct Entry, Concentrated Flow (Min)
5.0	633	Total			

Subcatchment C11: Drainage Basin C11

Hydrograph

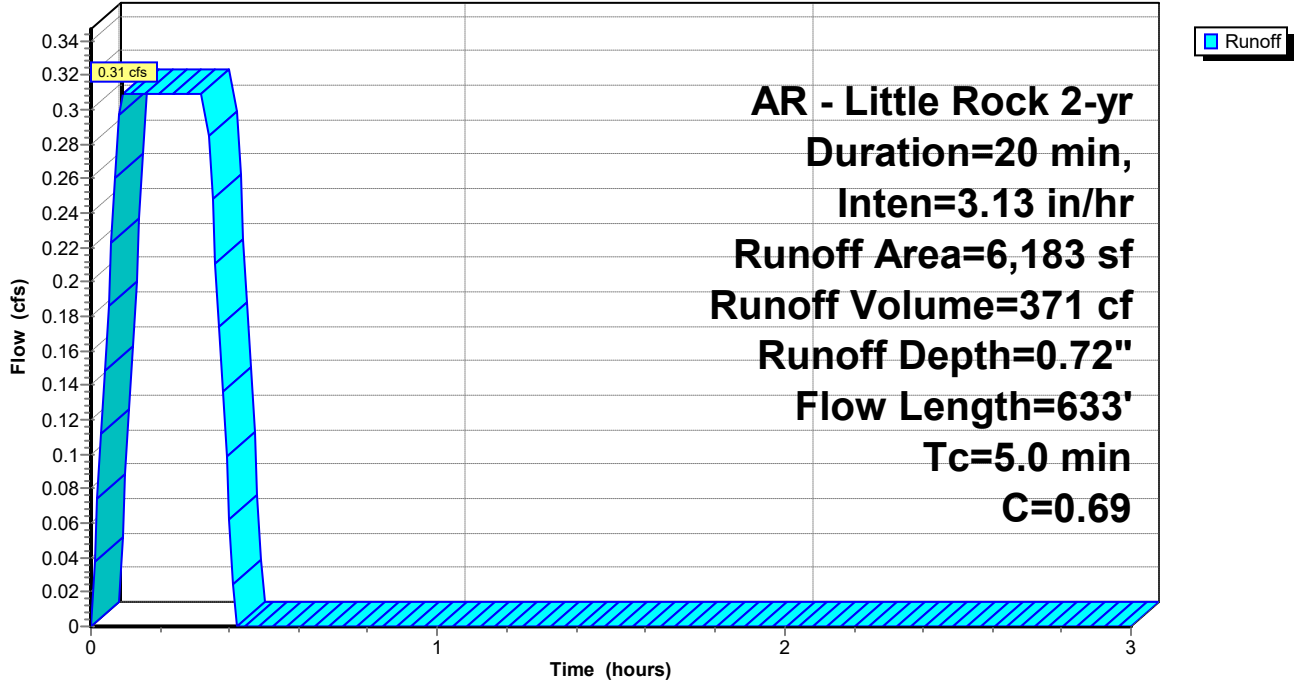

Goddard

Prepared by Phillip Lewis Engineering

HydroCAD® 10.20-5c s/n 12520 © 2023 HydroCAD Software Solutions LLC

AR - Little Rock 2-yr Duration=20 min, Inten=3.13 in/hr

Printed 3/25/2026

Summary for Subcatchment C12: Drainage Basin C12

Runoff = 1.49 cfs @ 0.09 hrs, Volume= 1,786 cf, Depth= 0.84"
 Routed to Pond CI-C7 : CI - C7

Runoff by Rational method, Rise/Fall=1.0/1.0 xTc, Time Span= 0.00-3.00 hrs, dt= 0.01 hrs
 AR - Little Rock 2-yr Duration=20 min, Inten=3.13 in/hr

Area (sf)	C	Description
7,218	0.40	Sod Yard
18,440	0.95	Paving, Sidewalks
25,658	0.80	Weighted Average
7,218		28.13% Pervious Area
18,440		71.87% Impervious Area

Tc (min)	Length (feet)	Slope (ft/ft)	Velocity (ft/sec)	Capacity (cfs)	Description
0.3	24	0.0360	1.50		Sheet Flow, Sheet Flow Smooth surfaces n= 0.011 P2= 4.19"
0.1	5	0.0190	0.85		Sheet Flow, Sheet Flow Smooth surfaces n= 0.011 P2= 4.19"
0.2	21	0.0100	2.03		Shallow Concentrated Flow, Concentrated Flow Paved Kv= 20.3 fps
0.9	49	0.0020	0.91		Shallow Concentrated Flow, Concentrated Flow Paved Kv= 20.3 fps
0.4	96	0.0330	3.69		Shallow Concentrated Flow, Concentrated Flow Paved Kv= 20.3 fps
0.3	94	0.0570	4.85		Shallow Concentrated Flow, Concentrated Flow Paved Kv= 20.3 fps
0.1	28	0.0560	4.80		Shallow Concentrated Flow, Concentrated Flow Paved Kv= 20.3 fps
0.1	25	0.0450	4.31		Shallow Concentrated Flow, Concentrated Flow Paved Kv= 20.3 fps
0.1	31	0.0410	4.11		Shallow Concentrated Flow, Concentrated Flow Paved Kv= 20.3 fps
0.1	39	0.0490	4.49		Shallow Concentrated Flow, Concentrated Flow Paved Kv= 20.3 fps
0.1	36	0.0460	4.35		Shallow Concentrated Flow, Concentrated Flow Paved Kv= 20.3 fps
0.0	11	0.0470	4.40		Shallow Concentrated Flow, Concentrated Flow Paved Kv= 20.3 fps
0.0	6	0.0440	4.26		Shallow Concentrated Flow, Concentrated Flow Paved Kv= 20.3 fps
2.3	415		3.01		Direct Entry, Concentrated Flow (Min)
5.0	880	Total			

Subcatchment C12: Drainage Basin C12

Hydrograph

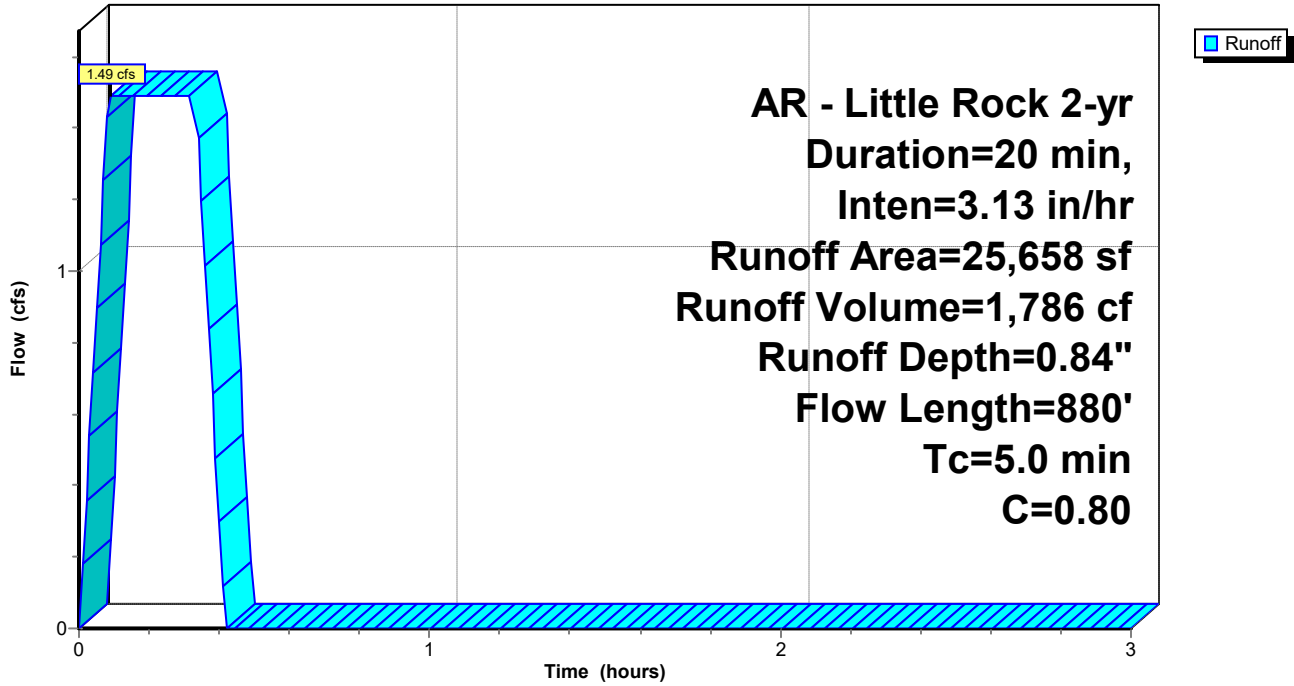

Goddard

Prepared by Phillip Lewis Engineering

HydroCAD® 10.20-5c s/n 12520 © 2023 HydroCAD Software Solutions LLC

AR - Little Rock 2-yr Duration=20 min, Inten=3.13 in/hr

Printed 3/25/2026

Summary for Subcatchment C13: Drainage Basin C13

Runoff = 0.48 cfs @ 0.09 hrs, Volume= 581 cf, Depth= 0.88"
 Routed to Pond CI-A4 : CI - A4

Runoff by Rational method, Rise/Fall=1.0/1.0 xTc, Time Span= 0.00-3.00 hrs, dt= 0.01 hrs
 AR - Little Rock 2-yr Duration=20 min, Inten=3.13 in/hr

Area (sf)	C	Description
1,558	0.40	Sod Yard
6,388	0.95	Paving, Sidewalks
7,946	0.84	Weighted Average
1,558		19.61% Pervious Area
6,388		80.39% Impervious Area

Tc (min)	Length (feet)	Slope (ft/ft)	Velocity (ft/sec)	Capacity (cfs)	Description
0.3	19	0.0200	1.13		Sheet Flow, Sheet Flow Smooth surfaces n= 0.011 P2= 4.19"
0.3	75	0.0340	3.74		Shallow Concentrated Flow, Concentrated Flow Paved Kv= 20.3 fps
0.2	52	0.0410	4.11		Shallow Concentrated Flow, Concentrated Flow Paved Kv= 20.3 fps
0.1	29	0.0470	4.40		Shallow Concentrated Flow, Concentrated Flow Paved Kv= 20.3 fps
0.1	42	0.0730	5.48		Shallow Concentrated Flow, Concentrated Flow Paved Kv= 20.3 fps
0.2	74	0.0750	5.56		Shallow Concentrated Flow, Concentrated Flow Paved Kv= 20.3 fps
0.1	26	0.0710	5.41		Shallow Concentrated Flow, Concentrated Flow Paved Kv= 20.3 fps
0.1	32	0.0570	4.85		Shallow Concentrated Flow, Concentrated Flow Paved Kv= 20.3 fps
0.0	13	0.0470	4.40		Shallow Concentrated Flow, Concentrated Flow Paved Kv= 20.3 fps
3.6	415		1.92		Direct Entry, Overland Concentrated Flow (Min)
5.0	777	Total			

Subcatchment C13: Drainage Basin C13

Hydrograph

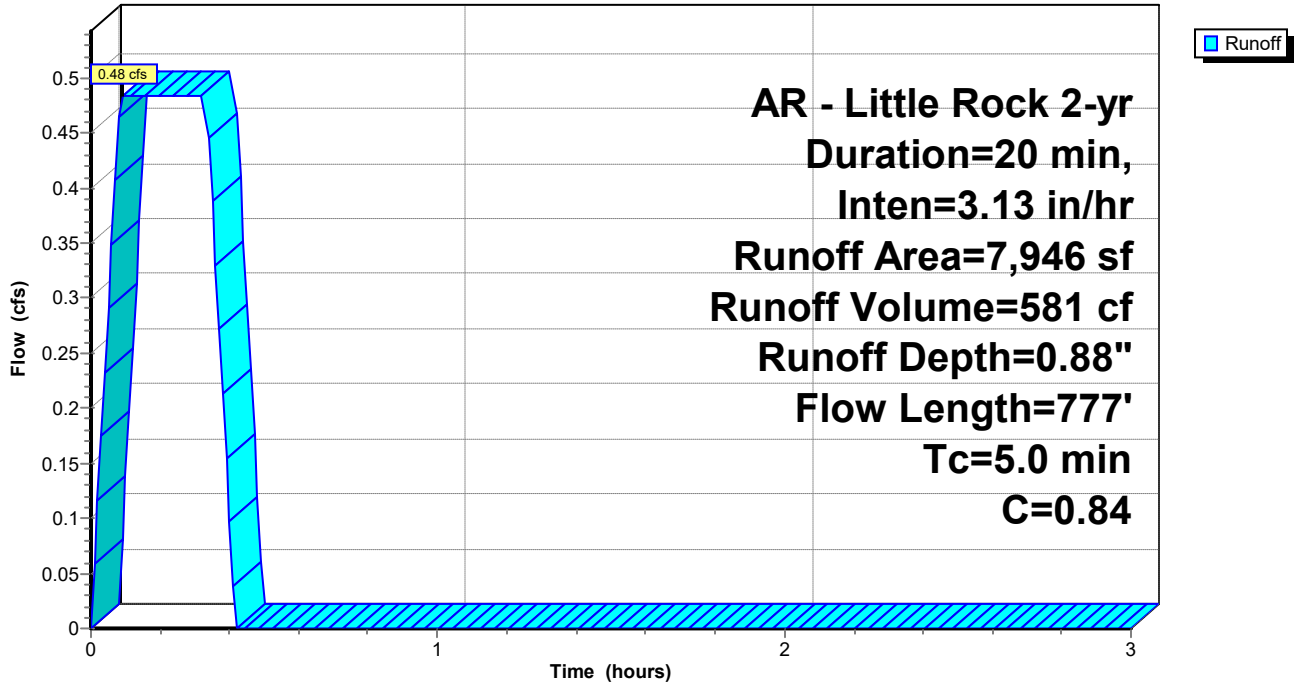

Goddard

Prepared by Phillip Lewis Engineering

HydroCAD® 10.20-5c s/n 12520 © 2023 HydroCAD Software Solutions LLC

AR - Little Rock 2-yr Duration=20 min, Inten=3.13 in/hr

Printed 3/25/2026

Summary for Subcatchment C14: Drainage Basin C14

Runoff = 1.28 cfs @ 0.27 hrs, Volume= 1,534 cf, Depth= 0.84"
 Routed to Pond CI-A5 : CI - A5

Runoff by Rational method, Rise/Fall=1.0/1.0 xTc, Time Span= 0.00-3.00 hrs, dt= 0.01 hrs
 AR - Little Rock 2-yr Duration=20 min, Inten=3.13 in/hr

Area (sf)	C	Description
6,127	0.40	Sod Yard
15,898	0.95	Paving, Sidewalks
22,025	0.80	Weighted Average
6,127		27.82% Pervious Area
15,898		72.18% Impervious Area

Tc (min)	Length (feet)	Slope (ft/ft)	Velocity (ft/sec)	Capacity (cfs)	Description
1.5	5	0.0310	0.06		Sheet Flow, Sheet Flow
					Grass: Bermuda n= 0.410 P2= 4.19"
9.2	45	0.0250	0.08		Sheet Flow, Sheet Flow
					Grass: Bermuda n= 0.410 P2= 4.19"
3.8	41	0.1940	0.18		Sheet Flow, Sheet Flow
					Grass: Bermuda n= 0.410 P2= 4.19"
0.1	6	0.0100	0.68		Sheet Flow, Sheet Flow
					Smooth surfaces n= 0.011 P2= 4.19"
0.1	51	0.0870	5.99		Shallow Concentrated Flow, Concentrated Flow
					Paved Kv= 20.3 fps
0.2	52	0.0310	3.57		Shallow Concentrated Flow, Concentrated Flow
					Paved Kv= 20.3 fps
0.1	18	0.0270	3.34		Shallow Concentrated Flow, Concentrated Flow
					Paved Kv= 20.3 fps
0.1	20	0.0400	4.06		Shallow Concentrated Flow, Concentrated Flow
					Paved Kv= 20.3 fps
0.1	34	0.0410	4.11		Shallow Concentrated Flow, Concentrated Flow
					Paved Kv= 20.3 fps
0.2	46	0.0470	4.40		Shallow Concentrated Flow, Concentrated Flow
					Paved Kv= 20.3 fps
0.1	36	0.0580	4.89		Shallow Concentrated Flow, Concentrated Flow
					Paved Kv= 20.3 fps
0.2	58	0.0690	5.33		Shallow Concentrated Flow, Concentrated Flow
					Paved Kv= 20.3 fps
0.1	49	0.0840	5.88		Shallow Concentrated Flow, Concentrated Flow
					Paved Kv= 20.3 fps
0.1	31	0.0690	5.33		Shallow Concentrated Flow, Concentrated Flow
					Paved Kv= 20.3 fps
15.9	492	Total			

Subcatchment C14: Drainage Basin C14

Hydrograph

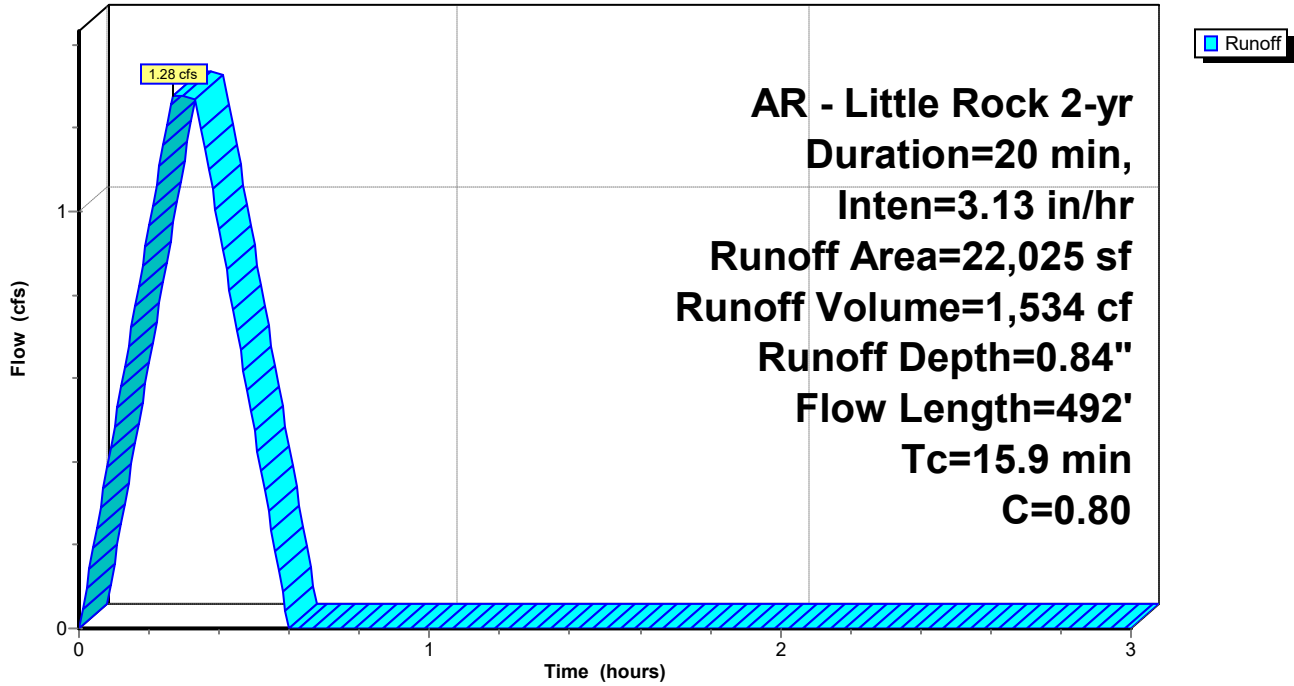

Summary for Subcatchment C15: Drainage Basin C15

Runoff = 0.93 cfs @ 0.09 hrs, Volume= 1,112 cf, Depth= 0.99"

Routed to Pond DP : Existing North Detention Pond

Runoff by Rational method, Rise/Fall=1.0/1.0 xTc, Time Span= 0.00-3.00 hrs, dt= 0.01 hrs

AR - Little Rock 2-yr Duration=20 min, Inten=3.13 in/hr

Area (sf)	C	Description
0	0.40	Sod Yard
13,450	0.95	Paving, Sidewalks
13,450	0.95	Weighted Average
13,450		100.00% Impervious Area

Tc (min)	Length (feet)	Slope (ft/ft)	Velocity (ft/sec)	Capacity (cfs)	Description
5.0	415		1.38		Direct Entry, Overland Concentrated Flow (Min)

Subcatchment C15: Drainage Basin C15

Hydrograph

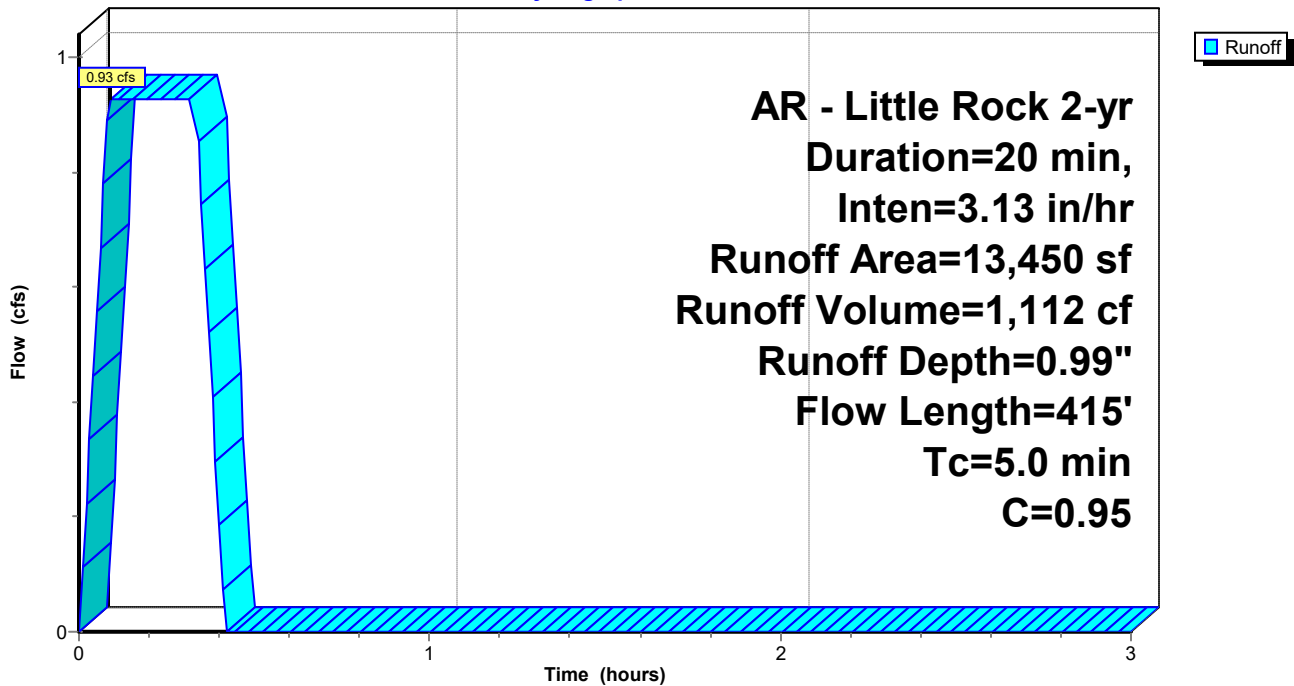

Goddard

Prepared by Phillip Lewis Engineering

HydroCAD® 10.20-5c s/n 12520 © 2023 HydroCAD Software Solutions LLC

AR - Little Rock 2-yr Duration=20 min, Inten=3.13 in/hr

Printed 3/25/2026

Summary for Subcatchment C16: Drainage Basin C16

Runoff = 0.90 cfs @ 0.09 hrs, Volume= 1,076 cf, Depth= 0.58"

Routed to Pond DP : Existing North Detention Pond

Runoff by Rational method, Rise/Fall=1.0/1.0 xTc, Time Span= 0.00-3.00 hrs, dt= 0.01 hrs

AR - Little Rock 2-yr Duration=20 min, Inten=3.13 in/hr

Area (sf)	C	Description
15,465	0.40	Sod Yard
6,612	0.95	Paving, Sidewalks
22,077	0.56	Weighted Average
15,465		70.05% Pervious Area
6,612		29.95% Impervious Area

Tc (min)	Length (feet)	Slope (ft/ft)	Velocity (ft/sec)	Capacity (cfs)	Description
0.4	26	0.0190	1.18		Sheet Flow, Sheet Flow
					Smooth surfaces n= 0.011 P2= 4.19"
0.1	5	0.0100	0.66		Sheet Flow, Sheet Flow
					Smooth surfaces n= 0.011 P2= 4.19"
0.4	51	0.0500	1.98		Sheet Flow, Sheet Flow
					Smooth surfaces n= 0.011 P2= 4.19"
0.1	12	0.1540	2.33		Sheet Flow, Sheet Flow
					Smooth surfaces n= 0.011 P2= 4.19"
0.1	50	0.1330	7.40		Shallow Concentrated Flow, Concentrated Flow
					Paved Kv= 20.3 fps
0.1	50	0.1170	6.94		Shallow Concentrated Flow, Concentrated Flow
					Paved Kv= 20.3 fps
0.2	46	0.0430	4.21		Shallow Concentrated Flow, Concentrated Flow
					Paved Kv= 20.3 fps
0.3	59	0.0370	3.90		Shallow Concentrated Flow, Concentrated Flow
					Paved Kv= 20.3 fps
3.3	415		2.10		Direct Entry, Overland Concentrated Flow (Min)
5.0	714	Total			

Subcatchment C16: Drainage Basin C16

Hydrograph

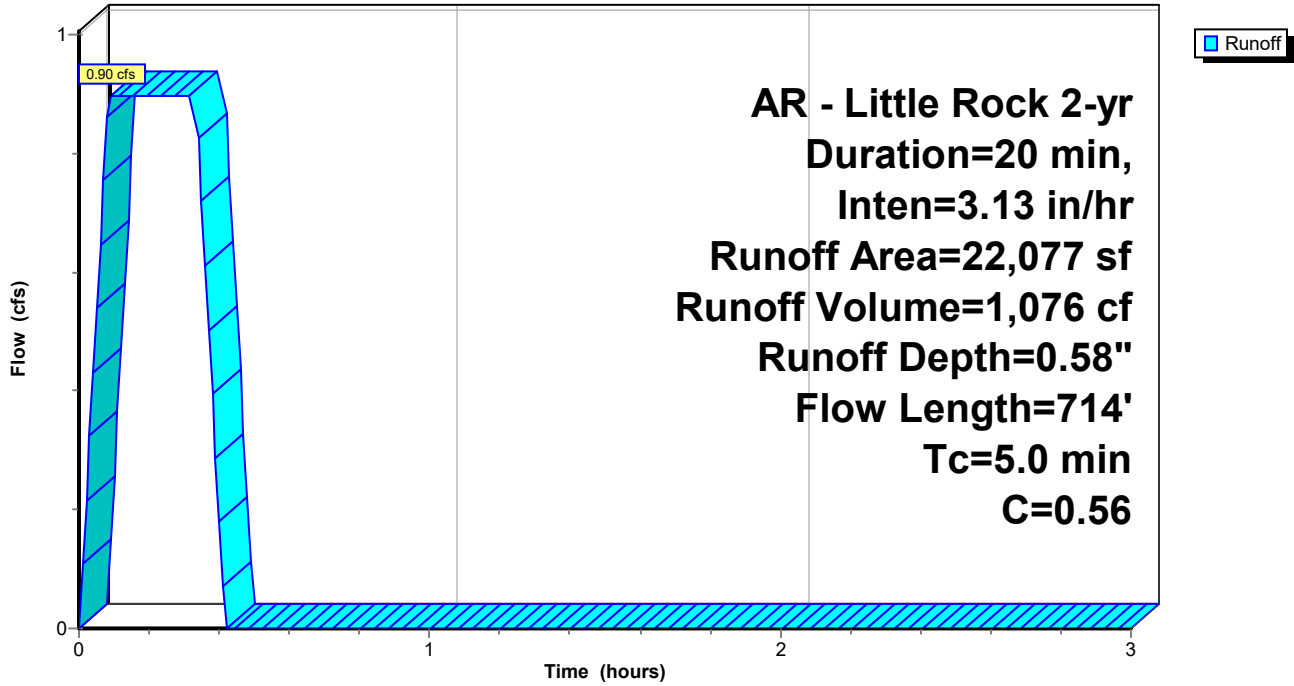

Goddard

Prepared by Phillip Lewis Engineering

HydroCAD® 10.20-5c s/n 12520 © 2023 HydroCAD Software Solutions LLC

AR - Little Rock 2-yr Duration=20 min, Inten=3.13 in/hr

Printed 3/25/2026

Summary for Subcatchment C17: Drainage Basin C17

Runoff = 1.65 cfs @ 0.16 hrs, Volume= 1,976 cf, Depth= 0.42"

Routed to Pond DP : Existing North Detention Pond

Runoff by Rational method, Rise/Fall=1.0/1.0 xTc, Time Span= 0.00-3.00 hrs, dt= 0.01 hrs

AR - Little Rock 2-yr Duration=20 min, Inten=3.13 in/hr

Area (sf)	C	Description
56,749	0.40	Sod Yard
0	0.95	Paving, Sidewalks
56,749	0.40	Weighted Average
56,749		100.00% Pervious Area

Tc (min)	Length (feet)	Slope (ft/ft)	Velocity (ft/sec)	Capacity (cfs)	Description
4.8	43	0.0410	0.15		Sheet Flow, Sheet Flow Grass: Dense n= 0.240 P2= 4.19"
3.9	43	0.0690	0.19		Sheet Flow, Sheet Flow Grass: Dense n= 0.240 P2= 4.19"
0.1	41	0.0980	4.70		Shallow Concentrated Flow, Concentrated Flow Grassed Waterway Kv= 15.0 fps
0.3	61	0.0730	4.05		Shallow Concentrated Flow, Concentrated Flow Grassed Waterway Kv= 15.0 fps
0.2	46	0.0570	3.58		Shallow Concentrated Flow, Concentrated Flow Grassed Waterway Kv= 15.0 fps
0.3	64	0.0450	3.18		Shallow Concentrated Flow, Concentrated Flow Grassed Waterway Kv= 15.0 fps
9.6	298	Total			

Subcatchment C17: Drainage Basin C17

Hydrograph

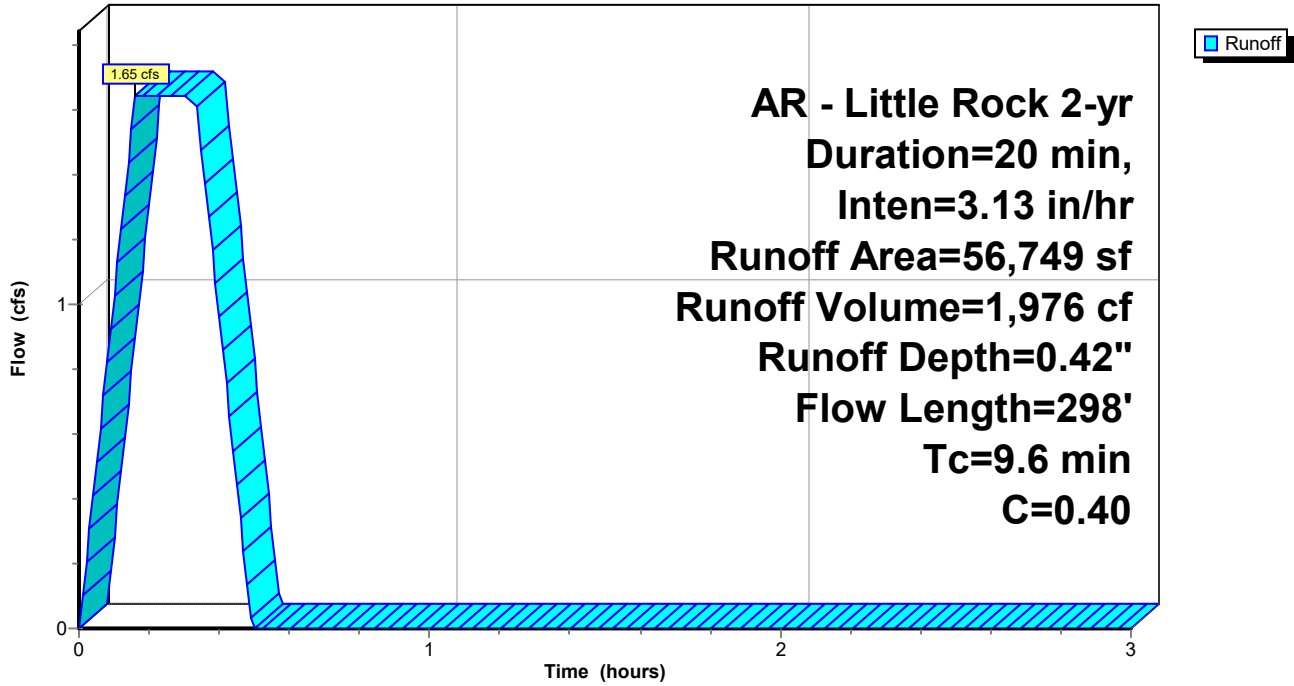

Goddard

AR - Little Rock 2-yr Duration=20 min, Inten=3.13 in/hr

Prepared by Phillip Lewis Engineering

Printed 3/25/2026

HydroCAD® 10.20-5c s/n 12520 © 2023 HydroCAD Software Solutions LLC

Summary for Subcatchment C18: Drainage Basin C18

Runoff = 1.06 cfs @ 0.09 hrs, Volume= 1,269 cf, Depth= 0.67"
 Routed to Link FINAL : APPROX DISCHARGE

Runoff by Rational method, Rise/Fall=1.0/1.0 xTc, Time Span= 0.00-3.00 hrs, dt= 0.01 hrs
 AR - Little Rock 2-yr Duration=20 min, Inten=3.13 in/hr

Area (sf)	C	Description
12,812	0.40	Sod Yard
9,973	0.95	Paving, Sidewalks
22,785	0.64	Weighted Average
12,812		56.23% Pervious Area
9,973		43.77% Impervious Area

Tc (min)	Length (feet)	Slope (ft/ft)	Velocity (ft/sec)	Capacity (cfs)	Description
0.6	5	0.2980	0.14		Sheet Flow, Sheet Flow Grass: Bermuda n= 0.410 P2= 4.19"
0.2	12	0.0130	0.87		Sheet Flow, Sheet Flow Smooth surfaces n= 0.011 P2= 4.19"
3.3	8	0.0100	0.04		Sheet Flow, Sheet Flow Grass: Bermuda n= 0.410 P2= 4.19"
0.5	80	0.0210	2.94		Shallow Concentrated Flow, Concentrated Flow Paved Kv= 20.3 fps
0.4	415		17.29		Direct Entry, Concentrated Flow (Min)
5.0	520	Total			

Subcatchment C18: Drainage Basin C18

Hydrograph

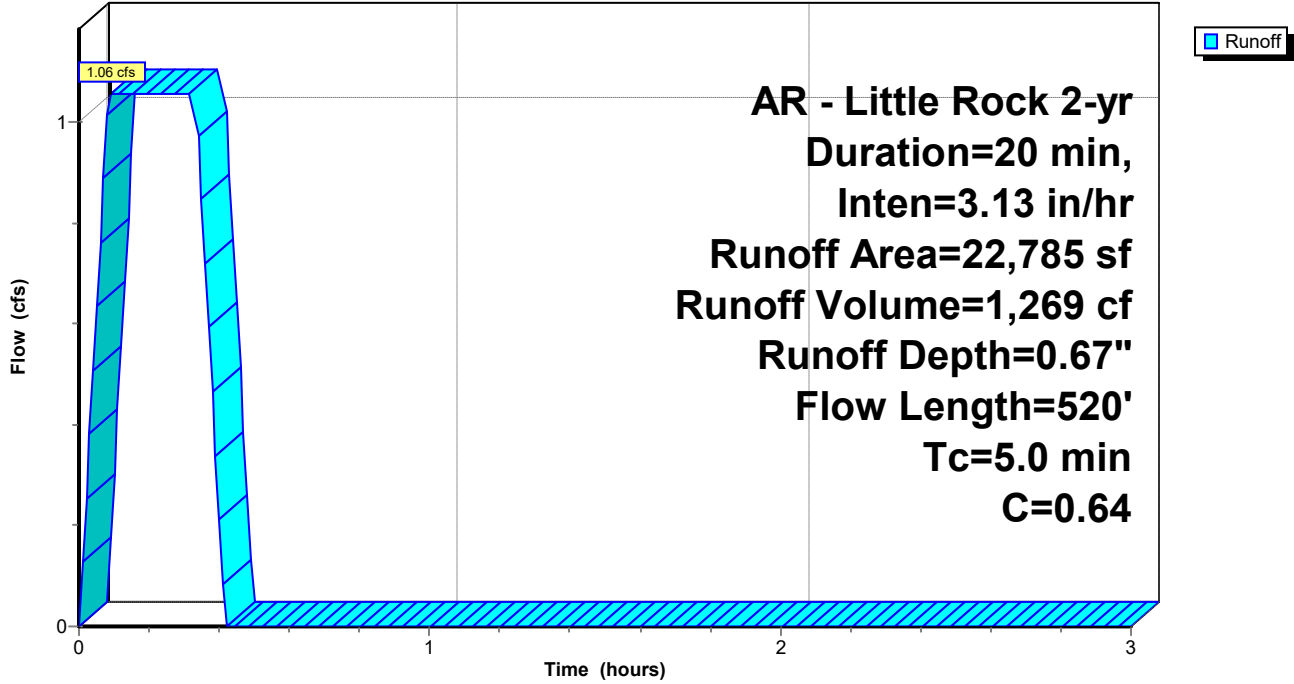

Goddard

Prepared by Phillip Lewis Engineering

HydroCAD® 10.20-5c s/n 12520 © 2023 HydroCAD Software Solutions LLC

AR - Little Rock 2-yr Duration=20 min, Inten=3.13 in/hr

Printed 3/25/2026

Summary for Subcatchment C19: Drainage Basin C19

Runoff = 0.52 cfs @ 0.12 hrs, Volume= 627 cf, Depth= 0.42"

Routed to Link FINAL : APPROX DISCHARGE

Runoff by Rational method, Rise/Fall=1.0/1.0 xTc, Time Span= 0.00-3.00 hrs, dt= 0.01 hrs

AR - Little Rock 2-yr Duration=20 min, Inten=3.13 in/hr

Area (sf)	C	Description
18,009	0.40	Sod Yard
0	0.95	Paving, Sidewalks
18,009	0.40	Weighted Average
18,009		100.00% Pervious Area

Tc (min)	Length (feet)	Slope (ft/ft)	Velocity (ft/sec)	Capacity (cfs)	Description
2.7	34	0.1110	0.21		Sheet Flow, Sheet Flow
					Grass: Dense n= 0.240 P2= 4.19"
3.3	66	0.2450	0.34		Sheet Flow, Sheet Flow
					Grass: Dense n= 0.240 P2= 4.19"
0.0	9	0.2450	7.42		Shallow Concentrated Flow, Concentrated Flow
					Grassed Waterway Kv= 15.0 fps
0.5	106	0.0610	3.70		Shallow Concentrated Flow, Concentrated Flow
					Grassed Waterway Kv= 15.0 fps
0.2	46	0.0800	4.24		Shallow Concentrated Flow, Concentrated Flow
					Grassed Waterway Kv= 15.0 fps
0.1	41	0.0960	4.65		Shallow Concentrated Flow, Concentrated Flow
					Grassed Waterway Kv= 15.0 fps
0.3	66	0.0680	3.91		Shallow Concentrated Flow, Concentrated Flow
					Grassed Waterway Kv= 15.0 fps
0.1	19	0.1070	4.91		Shallow Concentrated Flow, Concentrated Flow
					Grassed Waterway Kv= 15.0 fps
0.0	6	0.0750	4.11		Shallow Concentrated Flow, Concentrated Flow
					Grassed Waterway Kv= 15.0 fps
7.2	393	Total			

Subcatchment C19: Drainage Basin C19

Hydrograph

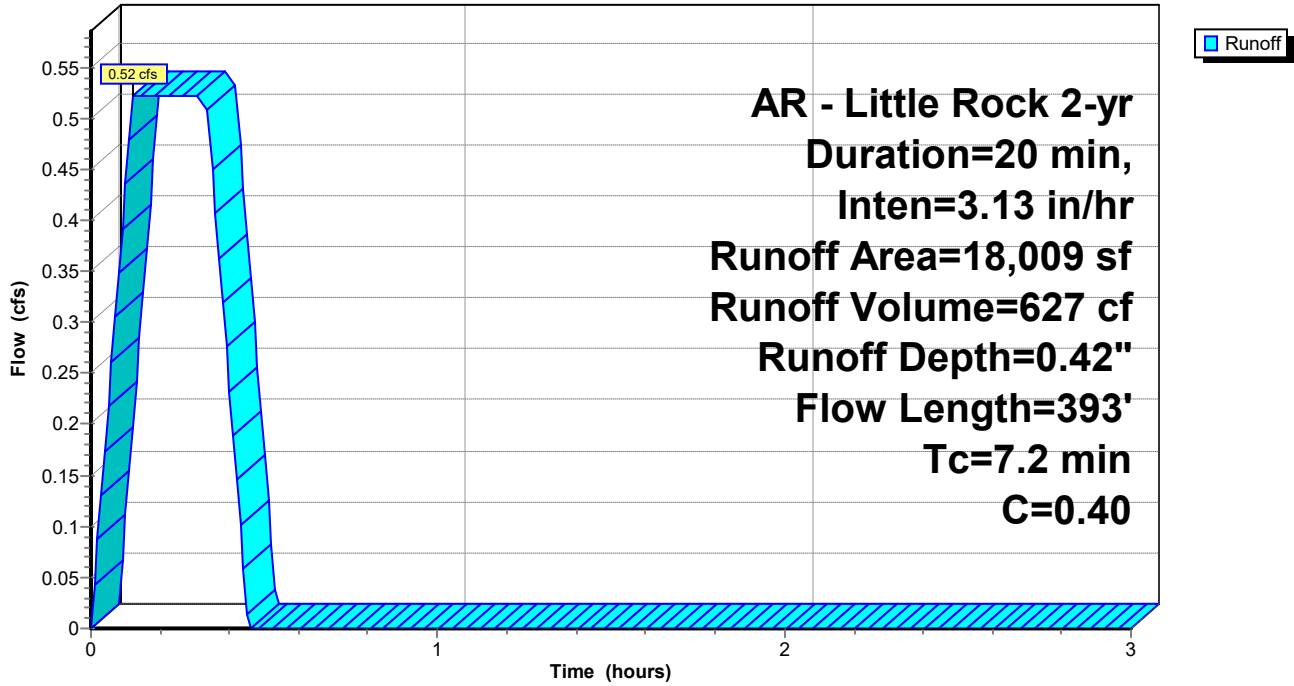

Goddard

Prepared by Phillip Lewis Engineering

HydroCAD® 10.20-5c s/n 12520 © 2023 HydroCAD Software Solutions LLC

AR - Little Rock 2-yr Duration=20 min, Inten=3.13 in/hr

Printed 3/25/2026

Summary for Subcatchment C2: Drainage Basin C2

Runoff = 1.92 cfs @ 0.09 hrs, Volume= 2,301 cf, Depth= 0.80"
 Routed to Pond CI-C2 : CI - C2

Runoff by Rational method, Rise/Fall=1.0/1.0 xTc, Time Span= 0.00-3.00 hrs, dt= 0.01 hrs
 AR - Little Rock 2-yr Duration=20 min, Inten=3.13 in/hr

Area (sf)	C	Description
11,376	0.40	Sod Yard
22,963	0.95	Roof, Paving, Sidewalks
34,339	0.77	Weighted Average
11,376		33.13% Pervious Area
22,963		66.87% Impervious Area

Tc (min)	Length (feet)	Slope (ft/ft)	Velocity (ft/sec)	Capacity (cfs)	Description
0.3	20	0.0200	1.14		Sheet Flow, Sheet Flow Smooth surfaces n= 0.011 P2= 4.19"
0.4	74	0.0240	3.14		Shallow Concentrated Flow, Concentrated Flow Paved Kv= 20.3 fps
0.1	17	0.0710	5.41		Shallow Concentrated Flow, Concentrated Flow Paved Kv= 20.3 fps
0.1	21	0.0610	5.01		Shallow Concentrated Flow, Concentrated Flow Paved Kv= 20.3 fps
0.6	148	0.0380	3.96		Shallow Concentrated Flow, Concentrated Flow Paved Kv= 20.3 fps
3.5	415		1.98		Direct Entry, Concentrated Flow (Min)
5.0	695	Total			

Subcatchment C2: Drainage Basin C2

Hydrograph

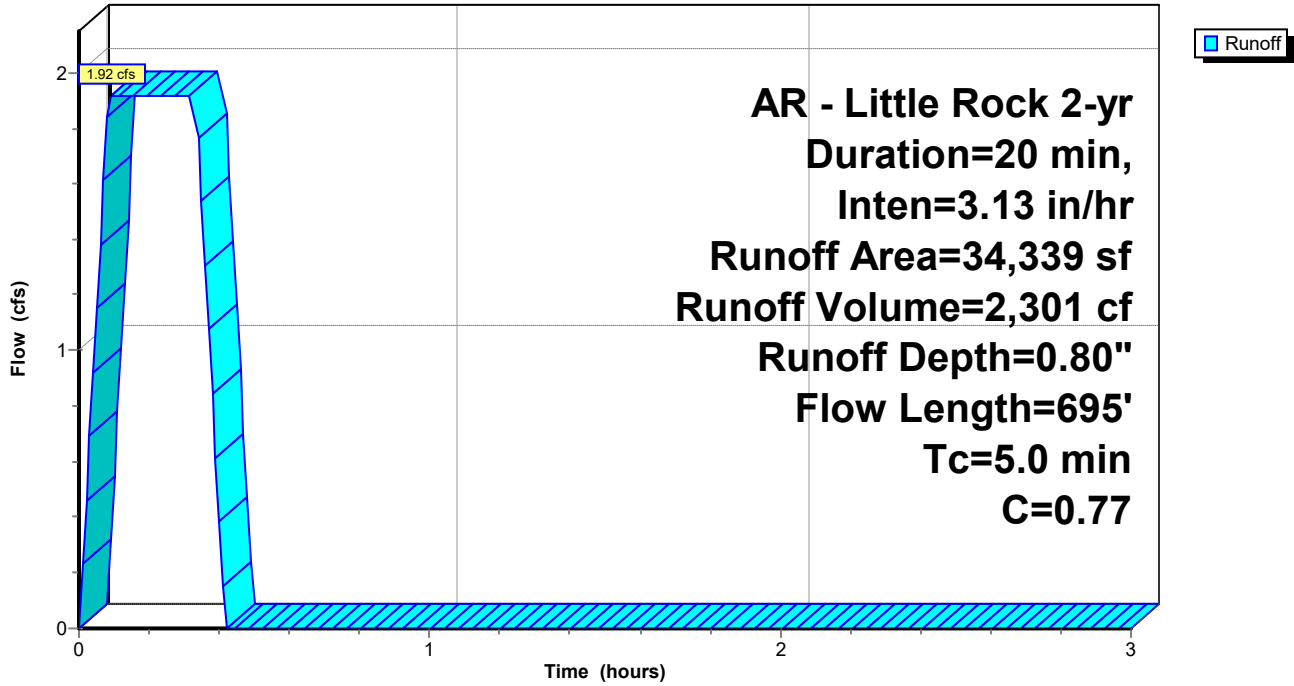

Goddard

Prepared by Phillip Lewis Engineering

HydroCAD® 10.20-5c s/n 12520 © 2023 HydroCAD Software Solutions LLC

AR - Little Rock 2-yr Duration=20 min, Inten=3.13 in/hr

Printed 3/25/2026

Summary for Subcatchment C20: Drainage Basin C20

Runoff = 0.89 cfs @ 0.14 hrs, Volume= 1,072 cf, Depth= 0.42"
 Routed to Link FINAL : APPROX DISCHARGE

Runoff by Rational method, Rise/Fall=1.0/1.0 xTc, Time Span= 0.00-3.00 hrs, dt= 0.01 hrs
 AR - Little Rock 2-yr Duration=20 min, Inten=3.13 in/hr

Area (sf)	C	Description
30,789	0.40	Sod Yard
0	0.95	Paving, Sidewalks
30,789	0.40	Weighted Average
30,789		100.00% Pervious Area

Tc (min)	Length (feet)	Slope (ft/ft)	Velocity (ft/sec)	Capacity (cfs)	Description
3.0	45	0.1430	0.25		Sheet Flow, Sheet Flow Grass: Dense n= 0.240 P2= 4.19"
4.5	55	0.0780	0.20		Sheet Flow, Sheet Flow Grass: Dense n= 0.240 P2= 4.19"
0.1	37	0.0780	4.19		Shallow Concentrated Flow, Concentrated Flow Grassed Waterway Kv= 15.0 fps
0.3	68	0.0710	4.00		Shallow Concentrated Flow, Concentrated Flow Grassed Waterway Kv= 15.0 fps
7.9	205	Total			

Subcatchment C20: Drainage Basin C20

Hydrograph

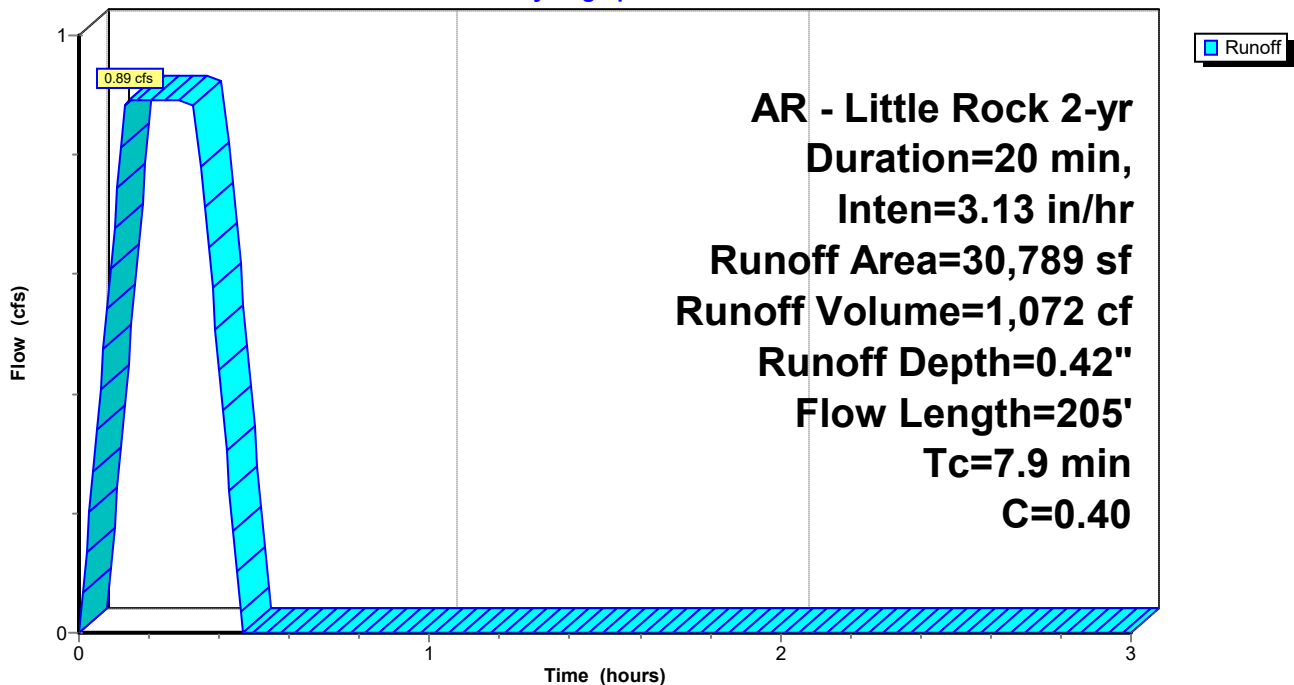

Goddard

Prepared by Phillip Lewis Engineering

HydroCAD® 10.20-5c s/n 12520 © 2023 HydroCAD Software Solutions LLC

AR - Little Rock 2-yr Duration=20 min, Inten=3.13 in/hr

Printed 3/25/2026

Summary for Subcatchment C3: Drainage Basin C3

Runoff = 0.24 cfs @ 0.09 hrs, Volume= 288 cf, Depth= 0.99"
 Routed to Pond CI-C3 : CI - C3

Runoff by Rational method, Rise/Fall=1.0/1.0 xTc, Time Span= 0.00-3.00 hrs, dt= 0.01 hrs
 AR - Little Rock 2-yr Duration=20 min, Inten=3.13 in/hr

Area (sf)	C	Description
0	0.40	Sod Yard
3,480	0.95	Paving, Sidewalks
3,480	0.95	Weighted Average
3,480		100.00% Impervious Area

Tc (min)	Length (feet)	Slope (ft/ft)	Velocity (ft/sec)	Capacity (cfs)	Description
0.3	22	0.0200	1.16		Sheet Flow, Sheet Flow Smooth surfaces n= 0.011 P2= 4.19"
0.0	10	0.0340	3.74		Shallow Concentrated Flow, Concentrated Flow Paved Kv= 20.3 fps
0.1	18	0.0390	4.01		Shallow Concentrated Flow, Concentrated Flow Paved Kv= 20.3 fps
0.6	147	0.0380	3.96		Shallow Concentrated Flow, Concentrated Flow Paved Kv= 20.3 fps
4.0	415		1.73		Direct Entry, Concentrated Flow (Min)
5.0	612	Total			

Subcatchment C3: Drainage Basin C3

Hydrograph

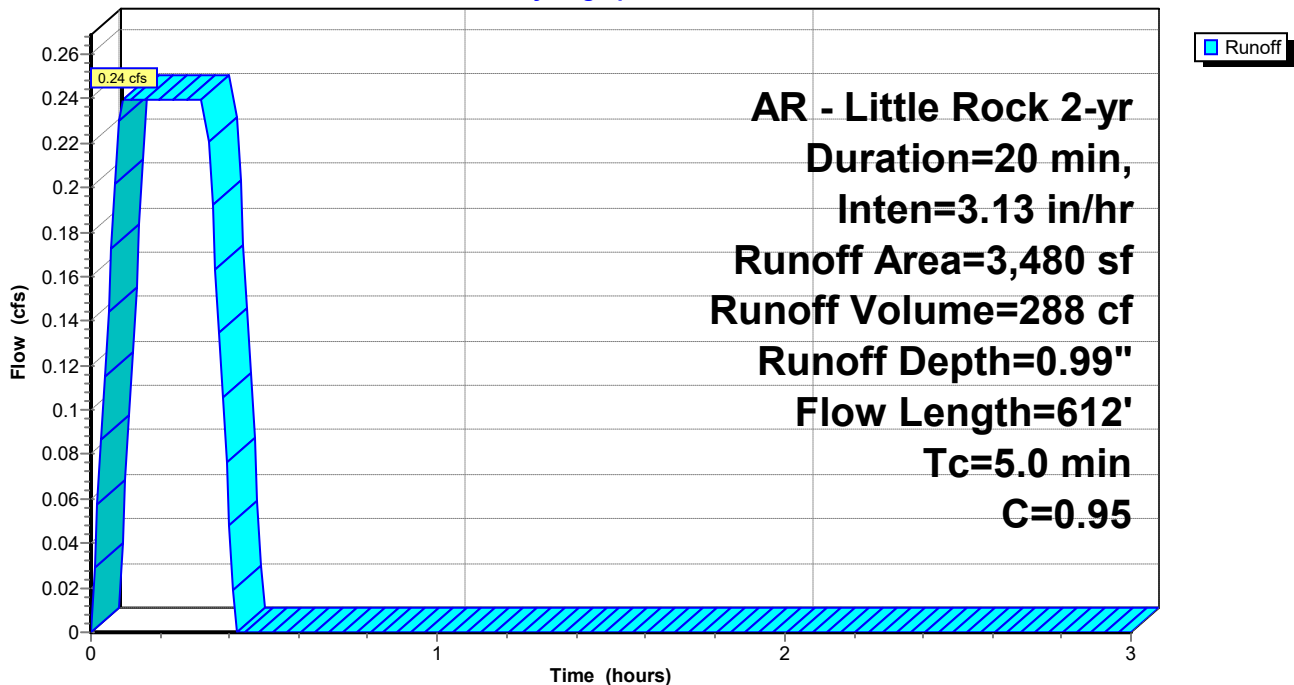

Summary for Subcatchment C4: Drainage Basin C4

Runoff = 0.46 cfs @ 0.09 hrs, Volume= 554 cf, Depth= 0.58"
 Routed to Pond CI-C3 : CI - C3

Runoff by Rational method, Rise/Fall=1.0/1.0 xTc, Time Span= 0.00-3.00 hrs, dt= 0.01 hrs
 AR - Little Rock 2-yr Duration=20 min, Inten=3.13 in/hr

Area (sf)	C	Description
8,130	0.40	Sod Yard
3,245	0.95	Paving, Sidewalks
11,375	0.56	Weighted Average
8,130		71.47% Pervious Area
3,245		28.53% Impervious Area

Tc (min)	Length (feet)	Slope (ft/ft)	Velocity (ft/sec)	Capacity (cfs)	Description
5.0	415		1.38		Direct Entry, Concentrated Flow (Min)

Subcatchment C4: Drainage Basin C4

Hydrograph

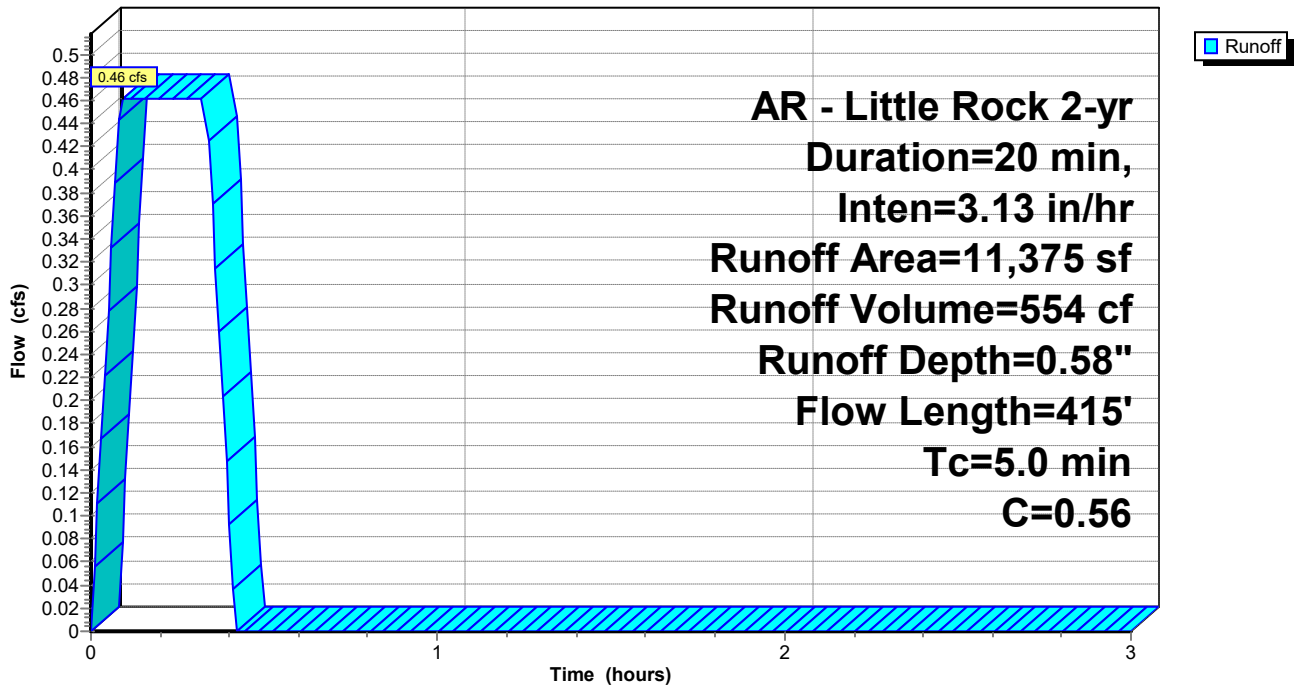

Goddard

Prepared by Phillip Lewis Engineering

HydroCAD® 10.20-5c s/n 12520 © 2023 HydroCAD Software Solutions LLC

AR - Little Rock 2-yr Duration=20 min, Inten=3.13 in/hr

Printed 3/25/2026

Summary for Subcatchment C5: Drainage Basin C5

Runoff = 0.40 cfs @ 0.10 hrs, Volume= 478 cf, Depth= 0.86"
 Routed to Pond CI-C4 : CI - C4

Runoff by Rational method, Rise/Fall=1.0/1.0 xTc, Time Span= 0.00-3.00 hrs, dt= 0.01 hrs
 AR - Little Rock 2-yr Duration=20 min, Inten=3.13 in/hr

Area (sf)	C	Description
1,634	0.40	Sod Yard
5,061	0.95	Paving, Sidewalks
6,695	0.82	Weighted Average
1,634		24.41% Pervious Area
5,061		75.59% Impervious Area

Tc (min)	Length (feet)	Slope (ft/ft)	Velocity (ft/sec)	Capacity (cfs)	Description
0.6	5	0.2990	0.14		Sheet Flow, Sheet Flow Grass: Bermuda n= 0.410 P2= 4.19"
0.2	12	0.0130	0.87		Sheet Flow, Sheet Flow Smooth surfaces n= 0.011 P2= 4.19"
3.9	8	0.0070	0.03		Sheet Flow, Sheet Flow Grass: Bermuda n= 0.410 P2= 4.19"
0.5	58	0.0080	1.82		Shallow Concentrated Flow, Concentrated Flow Paved Kv= 20.3 fps
0.1	14	0.0280	3.40		Shallow Concentrated Flow, Concentrated Flow Paved Kv= 20.3 fps
0.1	23	0.0370	3.90		Shallow Concentrated Flow, Concentrated Flow Paved Kv= 20.3 fps
0.0	13	0.0940	6.22		Shallow Concentrated Flow, Concentrated Flow Paved Kv= 20.3 fps
0.0	13	0.0560	4.80		Shallow Concentrated Flow, Concentrated Flow Paved Kv= 20.3 fps
0.2	30	0.0180	2.72		Shallow Concentrated Flow, Concentrated Flow Paved Kv= 20.3 fps
5.6	176	Total			

Subcatchment C5: Drainage Basin C5

Hydrograph

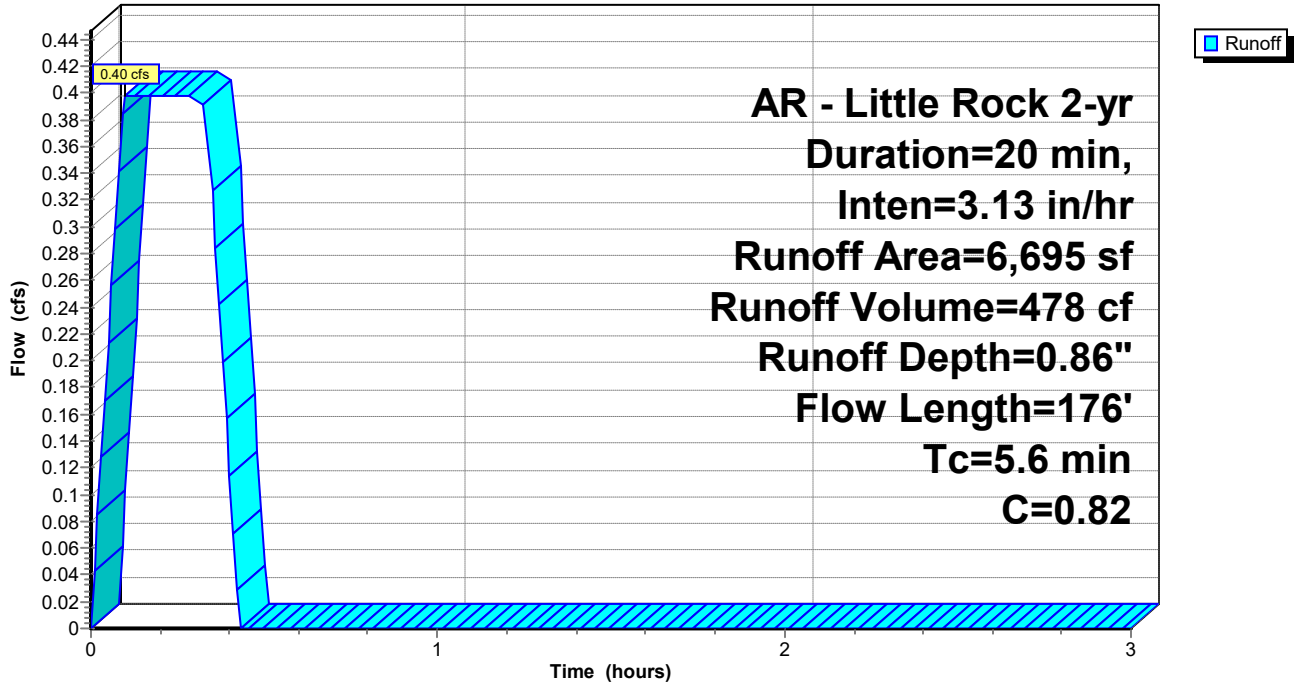

Goddard

Prepared by Phillip Lewis Engineering

HydroCAD® 10.20-5c s/n 12520 © 2023 HydroCAD Software Solutions LLC

AR - Little Rock 2-yr Duration=20 min, Inten=3.13 in/hr

Printed 3/25/2026

Summary for Subcatchment C6: Drainage Basin C6

Runoff = 0.20 cfs @ 0.09 hrs, Volume= 234 cf, Depth= 0.99"
 Routed to Pond CI-C5 : CI - C5

Runoff by Rational method, Rise/Fall=1.0/1.0 xTc, Time Span= 0.00-3.00 hrs, dt= 0.01 hrs
 AR - Little Rock 2-yr Duration=20 min, Inten=3.13 in/hr

Area (sf)	C	Description
0	0.40	Sod Yard
2,835	0.95	Paving, Sidewalks
2,835	0.95	Weighted Average
2,835		100.00% Impervious Area

Tc (min)	Length (feet)	Slope (ft/ft)	Velocity (ft/sec)	Capacity (cfs)	Description
0.3	22	0.0200	1.16		Sheet Flow, Sheet Flow Smooth surfaces n= 0.011 P2= 4.19"
0.2	19	0.0100	2.03		Shallow Concentrated Flow, Concentrated Flow Paved Kv= 20.3 fps
0.1	17	0.0170	2.65		Shallow Concentrated Flow, Concentrated Flow Paved Kv= 20.3 fps
0.1	26	0.0360	3.85		Shallow Concentrated Flow, Concentrated Flow Paved Kv= 20.3 fps
0.1	28	0.0610	5.01		Shallow Concentrated Flow, Concentrated Flow Paved Kv= 20.3 fps
0.1	27	0.0610	5.01		Shallow Concentrated Flow, Concentrated Flow Paved Kv= 20.3 fps
4.1	415		1.69		Direct Entry, Concentrated Flow (Min)
5.0	554	Total			

Subcatchment C6: Drainage Basin C6

Hydrograph

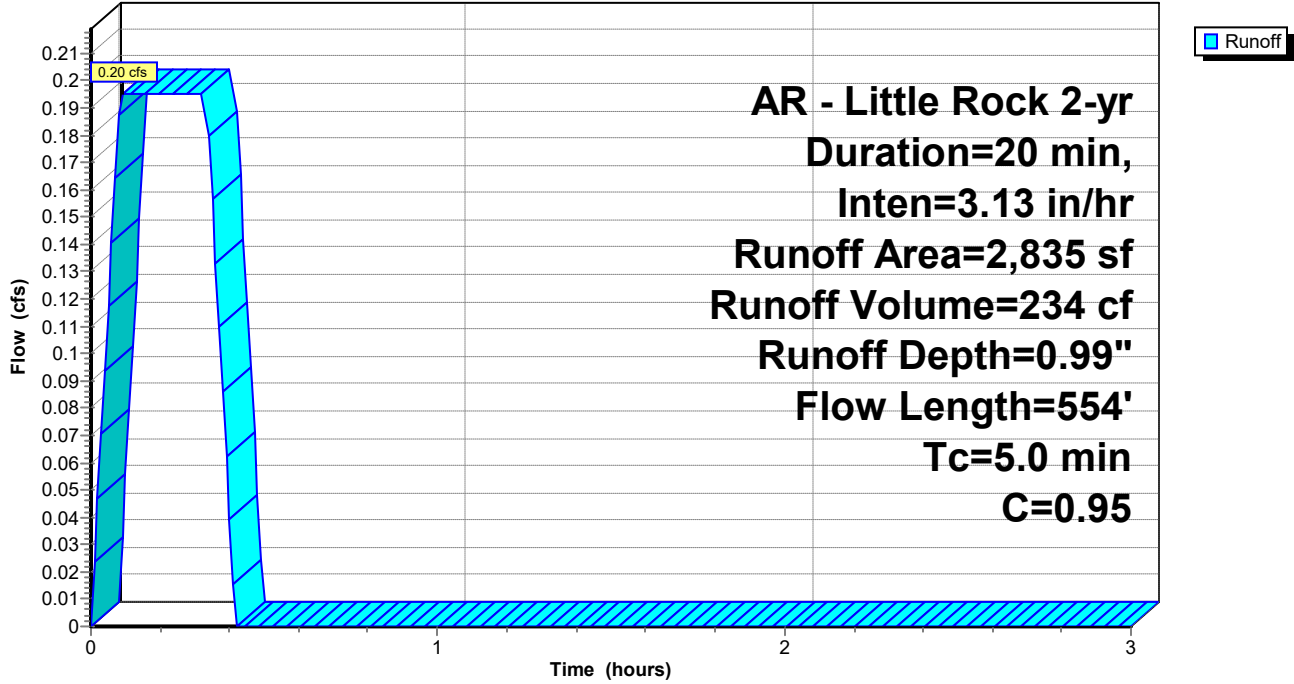

Goddard

Prepared by Phillip Lewis Engineering

HydroCAD® 10.20-5c s/n 12520 © 2023 HydroCAD Software Solutions LLC

AR - Little Rock 2-yr Duration=20 min, Inten=3.13 in/hr

Printed 3/25/2026

Summary for Subcatchment C7: Drainage Basin C7

Runoff = 0.11 cfs @ 0.09 hrs, Volume= 132 cf, Depth= 0.99"
 Routed to Pond CI-D1 : CI - D1

Runoff by Rational method, Rise/Fall=1.0/1.0 xTc, Time Span= 0.00-3.00 hrs, dt= 0.01 hrs
 AR - Little Rock 2-yr Duration=20 min, Inten=3.13 in/hr

Area (sf)	C	Description
0	0.40	Sod Yard
1,597	0.95	Paving, Sidewalks
1,597	0.95	Weighted Average
1,597		100.00% Impervious Area

Tc (min)	Length (feet)	Slope (ft/ft)	Velocity (ft/sec)	Capacity (cfs)	Description
0.3	19	0.0200	1.13		Sheet Flow, Sheet Flow Smooth surfaces n= 0.011 P2= 4.19"
0.1	16	0.0540	4.72		Shallow Concentrated Flow, Concentrated Flow Paved Kv= 20.3 fps
0.3	81	0.0580	4.89		Shallow Concentrated Flow, Concentrated Flow Paved Kv= 20.3 fps
4.3	415		1.61		Direct Entry, Concentrated Flow (Min)
5.0	531	Total			

Subcatchment C7: Drainage Basin C7

Hydrograph

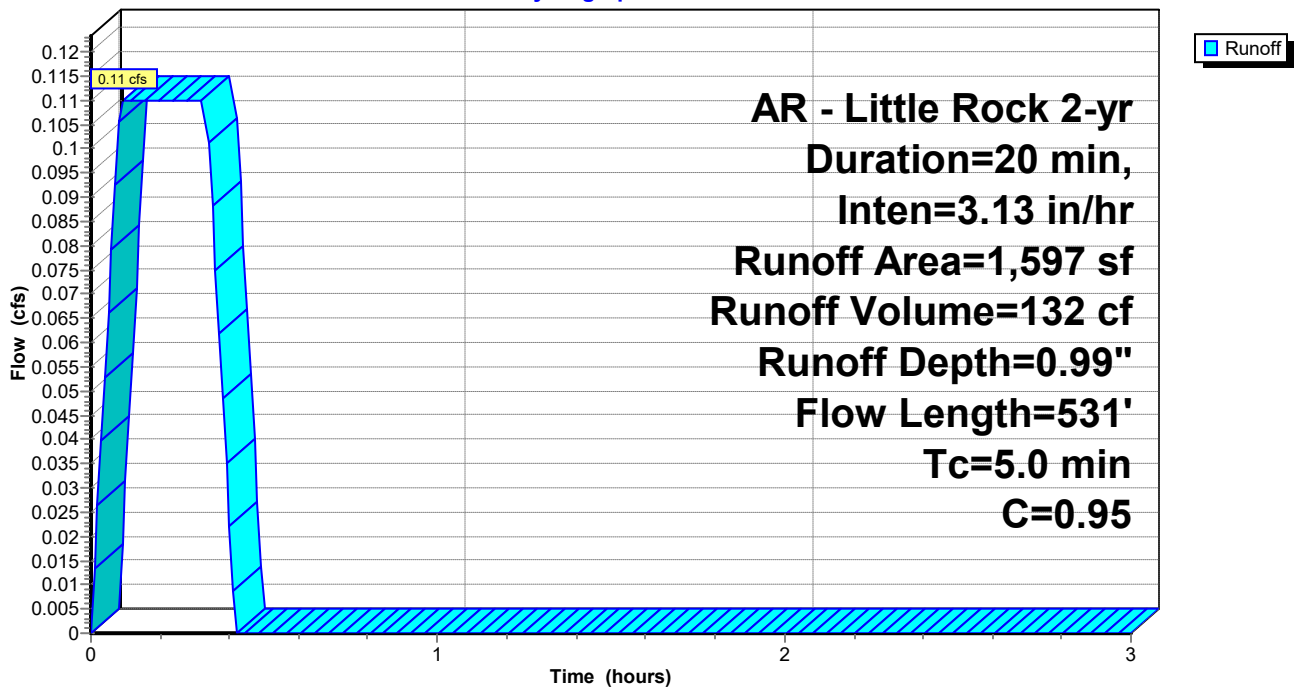

Goddard

Prepared by Phillip Lewis Engineering

HydroCAD® 10.20-5c s/n 12520 © 2023 HydroCAD Software Solutions LLC

AR - Little Rock 2-yr Duration=20 min, Inten=3.13 in/hr

Printed 3/25/2026

Summary for Subcatchment C8: Drainage Basin C8

Runoff = 0.11 cfs @ 0.09 hrs, Volume= 128 cf, Depth= 0.99"
 Routed to Pond CI-D2 : CI - D2

Runoff by Rational method, Rise/Fall=1.0/1.0 xTc, Time Span= 0.00-3.00 hrs, dt= 0.01 hrs
 AR - Little Rock 2-yr Duration=20 min, Inten=3.13 in/hr

Area (sf)	C	Description
0	0.40	Sod Yard
1,548	0.95	Paving, Sidewalks
1,548	0.95	Weighted Average
1,548		100.00% Impervious Area

Tc (min)	Length (feet)	Slope (ft/ft)	Velocity (ft/sec)	Capacity (cfs)	Description
0.3	18	0.0200	1.12		Sheet Flow, Sheet Flow Smooth surfaces n= 0.011 P2= 4.19"
0.3	94	0.0610	5.01		Shallow Concentrated Flow, Concentrated Flow Paved Kv= 20.3 fps
4.4	415		1.57		Direct Entry, Concentrated Flow (Min)
5.0	527	Total			

Subcatchment C8: Drainage Basin C8

Hydrograph

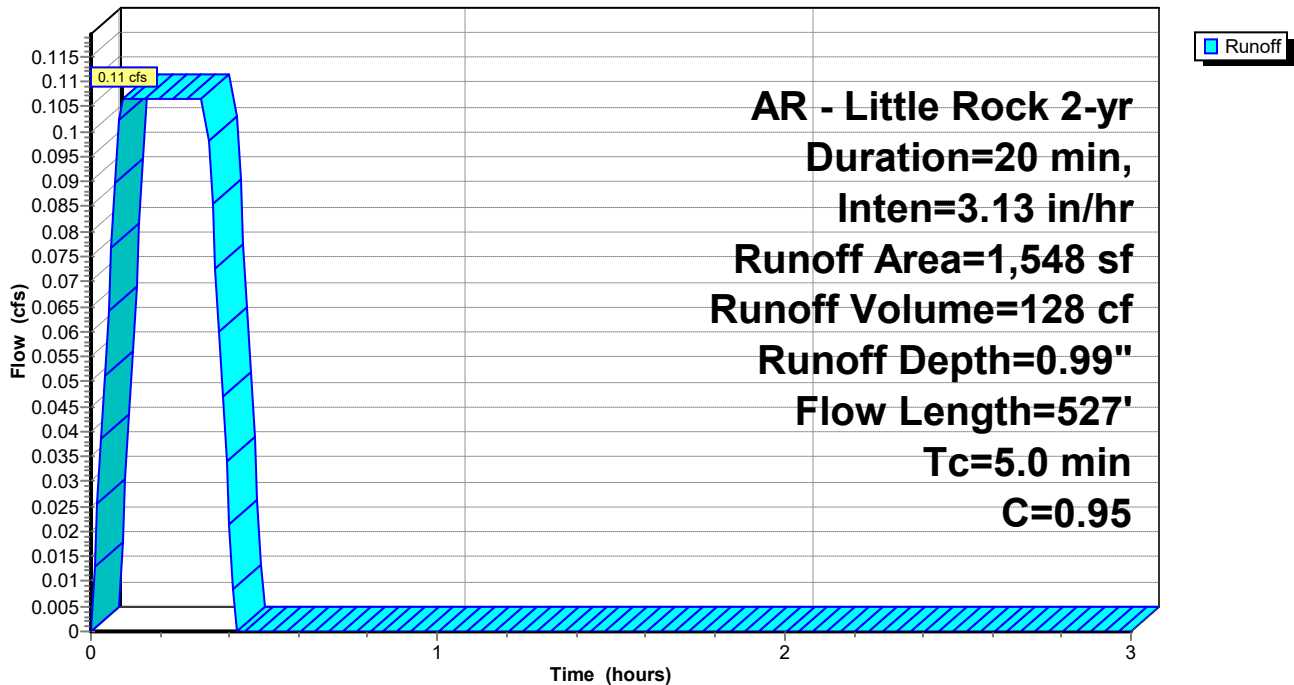

Goddard

Prepared by Phillip Lewis Engineering

HydroCAD® 10.20-5c s/n 12520 © 2023 HydroCAD Software Solutions LLC

AR - Little Rock 2-yr Duration=20 min, Inten=3.13 in/hr

Printed 3/25/2026

Summary for Subcatchment C9: Drainage Basin C9

Runoff = 0.77 cfs @ 0.09 hrs, Volume= 926 cf, Depth= 0.80"
 Routed to Pond CI-C6 : CI - C6

Runoff by Rational method, Rise/Fall=1.0/1.0 xTc, Time Span= 0.00-3.00 hrs, dt= 0.01 hrs
 AR - Little Rock 2-yr Duration=20 min, Inten=3.13 in/hr

Area (sf)	C	Description
4,456	0.40	Sod Yard
9,361	0.95	Paving, Sidewalks
13,817	0.77	Weighted Average
4,456		32.25% Pervious Area
9,361		67.75% Impervious Area

Tc (min)	Length (feet)	Slope (ft/ft)	Velocity (ft/sec)	Capacity (cfs)	Description
1.2	100	0.0140	1.36		Sheet Flow, Sheet Flow Smooth surfaces n= 0.011 P2= 4.19"
0.1	13	0.0150	2.49		Shallow Concentrated Flow, Concentrated Flow Paved Kv= 20.3 fps
0.1	23	0.0160	2.57		Shallow Concentrated Flow, Concentrated Flow Paved Kv= 20.3 fps
0.1	7	0.0050	1.44		Shallow Concentrated Flow, Concentrated Flow Paved Kv= 20.3 fps
0.1	8	0.0100	2.03		Shallow Concentrated Flow, Concentrated Flow Paved Kv= 20.3 fps
0.2	41	0.0420	4.16		Shallow Concentrated Flow, Concentrated Flow Paved Kv= 20.3 fps
0.1	41	0.0540	4.72		Shallow Concentrated Flow, Concentrated Flow Paved Kv= 20.3 fps
0.2	61	0.0520	4.63		Shallow Concentrated Flow, Concentrated Flow Paved Kv= 20.3 fps
2.9	415		2.39		Direct Entry, Concentrated Flow (Min)
5.0	709	Total			

Subcatchment C9: Drainage Basin C9

Hydrograph

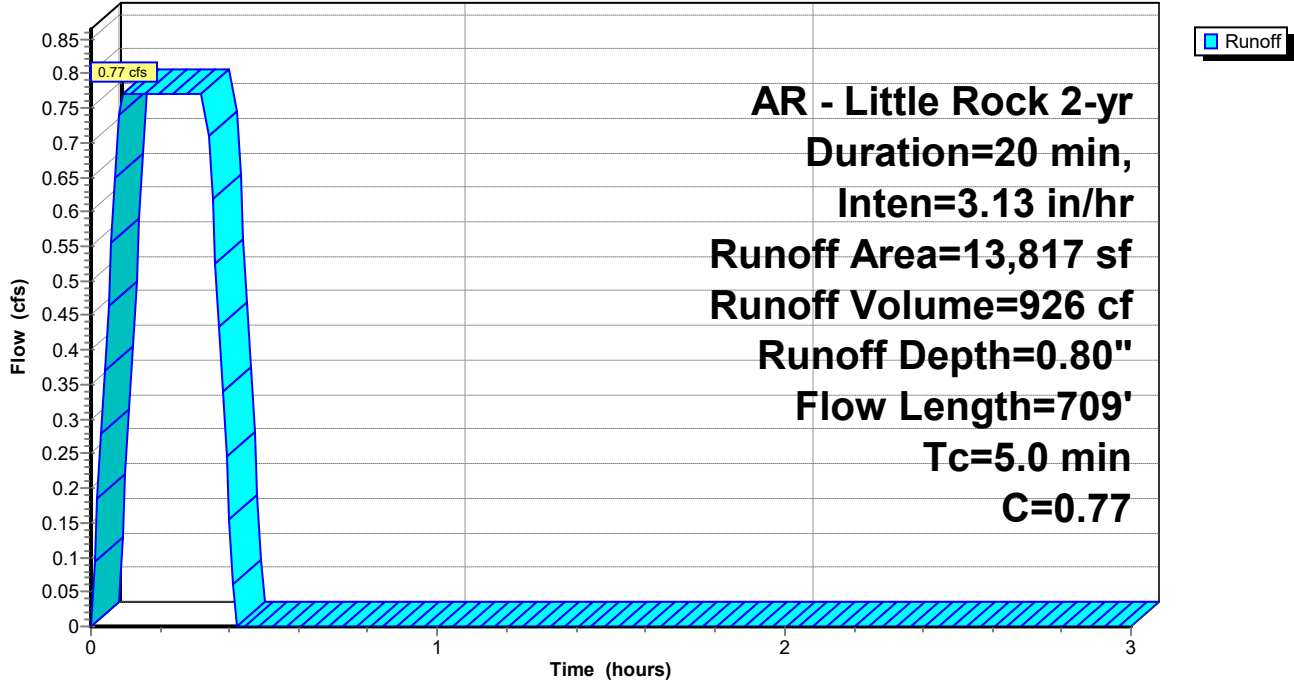

Goddard

Prepared by Phillip Lewis Engineering

HydroCAD® 10.20-5c s/n 12520 © 2023 HydroCAD Software Solutions LLC

AR - Little Rock 2-yr Duration=20 min, Inten=3.13 in/hr

Printed 3/25/2026

Summary for Pond CI-A1: CI - A1

Inflow Area = 19,493 sf, 74.78% Impervious, Inflow Depth = 0.88" for 2-yr event
Inflow = 1.19 cfs @ 0.09 hrs, Volume= 1,425 cf
Primary = 1.19 cfs @ 0.09 hrs, Volume= 1,425 cf, Atten= 0%, Lag= 0.0 min
Routed to Pond JB-A2 : JB - A2

Routing by Stor-Ind method, Time Span= 0.00-3.00 hrs, dt= 0.01 hrs

Pond CI-A1: CI - A1

Hydrograph

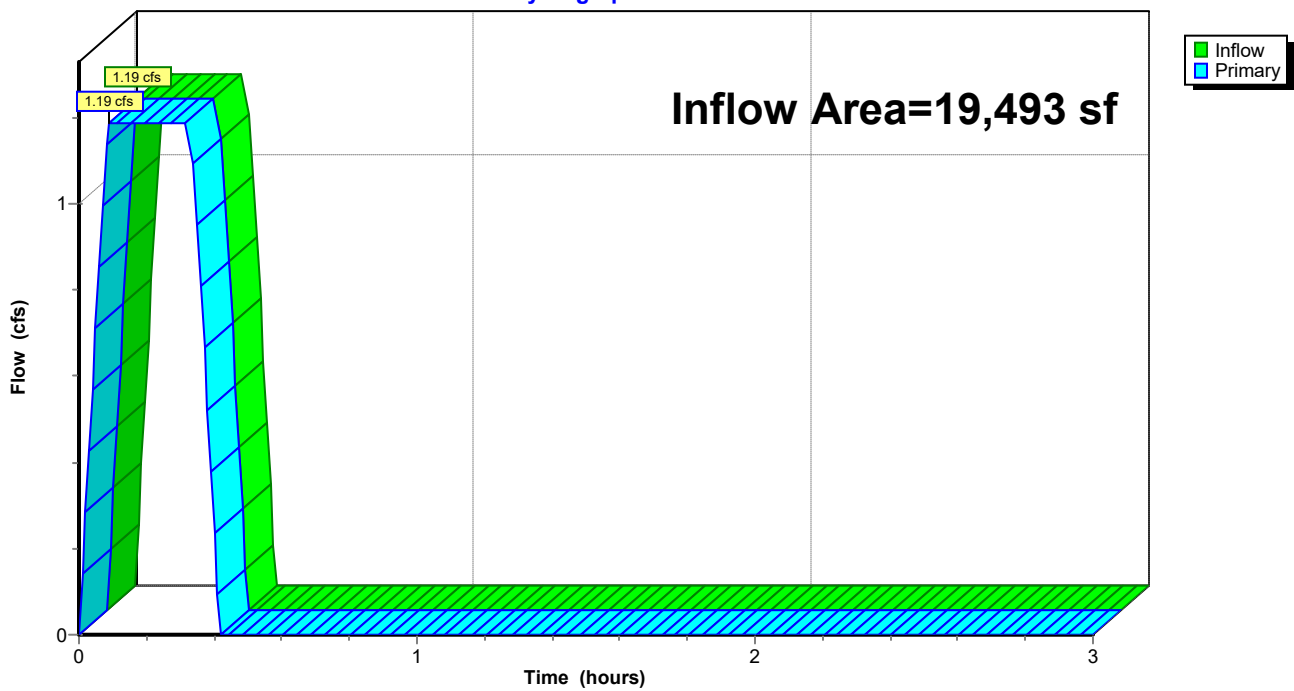

Summary for Pond CI-A3: CI - A3

Inflow Area = 52,824 sf, 61.20% Impervious, Inflow Depth = 0.81" for 2-yr event
Inflow = 2.99 cfs @ 0.17 hrs, Volume= 3,583 cf
Primary = 2.99 cfs @ 0.17 hrs, Volume= 3,583 cf, Atten= 0%, Lag= 0.0 min
Routed to Pond CI-A4 : CI - A4

Routing by Stor-Ind method, Time Span= 0.00-3.00 hrs, dt= 0.01 hrs

Pond CI-A3: CI - A3

Hydrograph

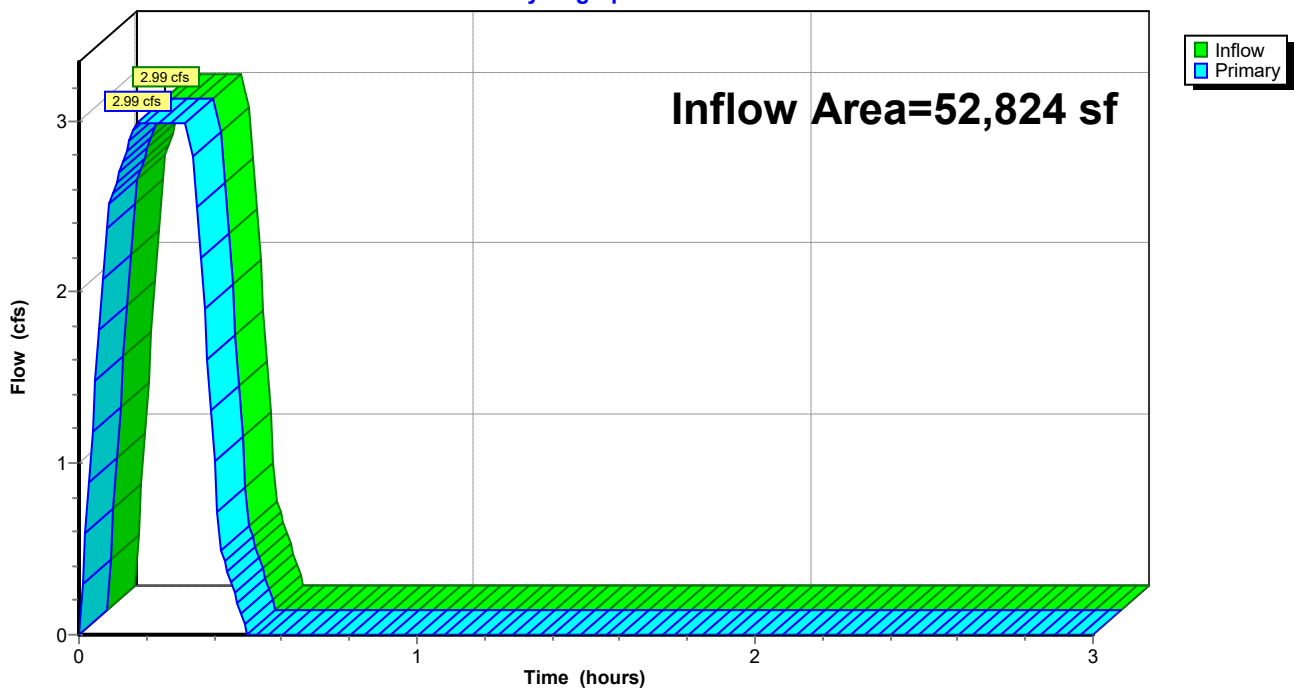

Summary for Pond CI-A4: CI - A4

Inflow Area = 75,210 sf, 60.06% Impervious, Inflow Depth = 0.81" for 2-yr event
Inflow = 4.21 cfs @ 0.24 hrs, Volume= 5,056 cf
Primary = 4.21 cfs @ 0.24 hrs, Volume= 5,056 cf, Atten= 0%, Lag= 0.0 min
Routed to Pond CI-A5 : CI - A5

Routing by Stor-Ind method, Time Span= 0.00-3.00 hrs, dt= 0.01 hrs

Pond CI-A4: CI - A4

Hydrograph

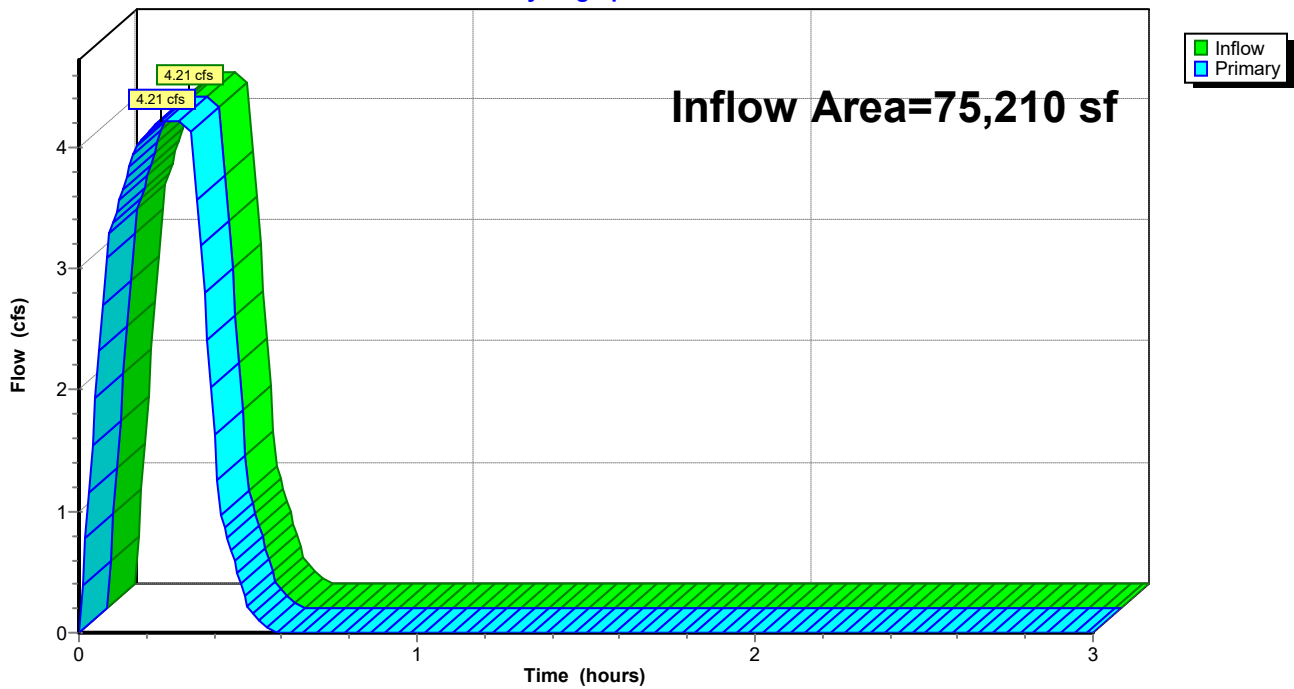

Summary for Pond CI-A5: CI - A5

Inflow Area = 97,235 sf, 62.81% Impervious, Inflow Depth = 0.81" for 2-yr event
Inflow = 5.49 cfs @ 0.27 hrs, Volume= 6,590 cf
Primary = 5.49 cfs @ 0.27 hrs, Volume= 6,590 cf, Atten= 0%, Lag= 0.0 min
Routed to Pond DP : Existing North Detention Pond

Routing by Stor-Ind method, Time Span= 0.00-3.00 hrs, dt= 0.01 hrs

Pond CI-A5: CI - A5

Hydrograph

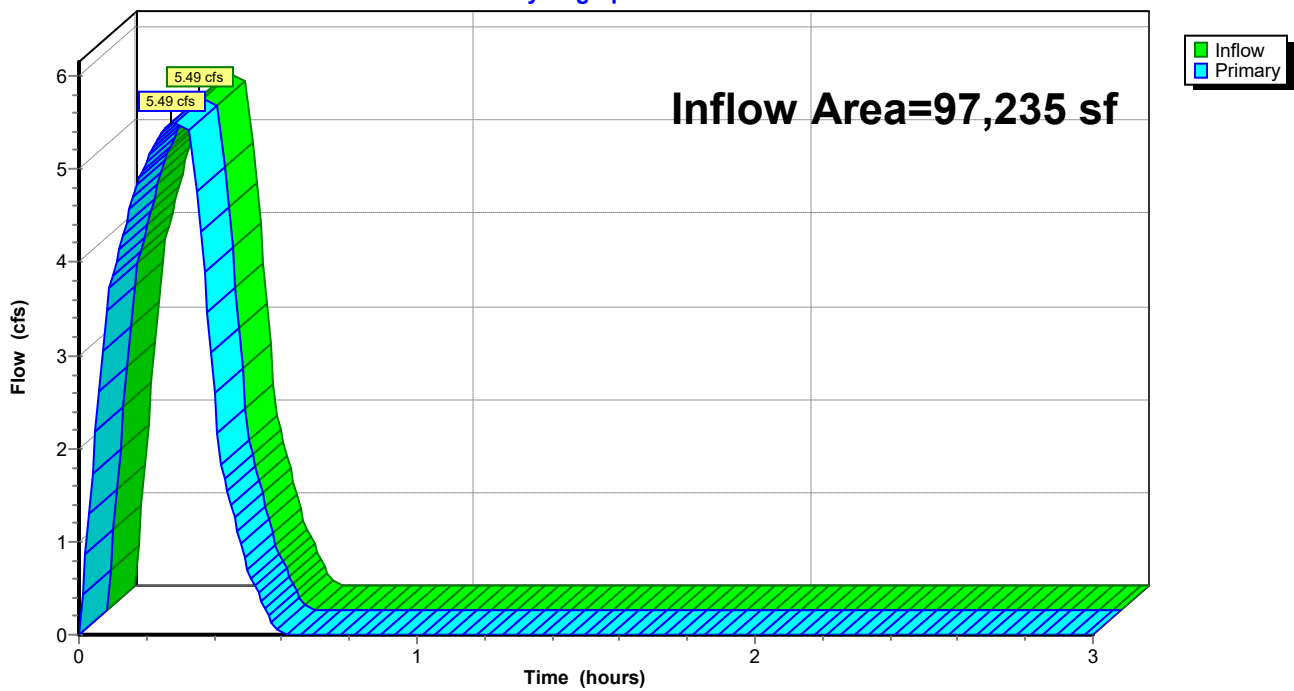

Summary for Pond CI-B2: CI - B2

Inflow Area = 22,169 sf, 29.72% Impervious, Inflow Depth = 0.67" for 2-yr event
Inflow = 1.03 cfs @ 0.17 hrs, Volume= 1,235 cf
Primary = 1.03 cfs @ 0.17 hrs, Volume= 1,235 cf, Atten= 0%, Lag= 0.0 min
Routed to Pond JB-A2 : JB - A2

Routing by Stor-Ind method, Time Span= 0.00-3.00 hrs, dt= 0.01 hrs

Pond CI-B2: CI - B2

Hydrograph

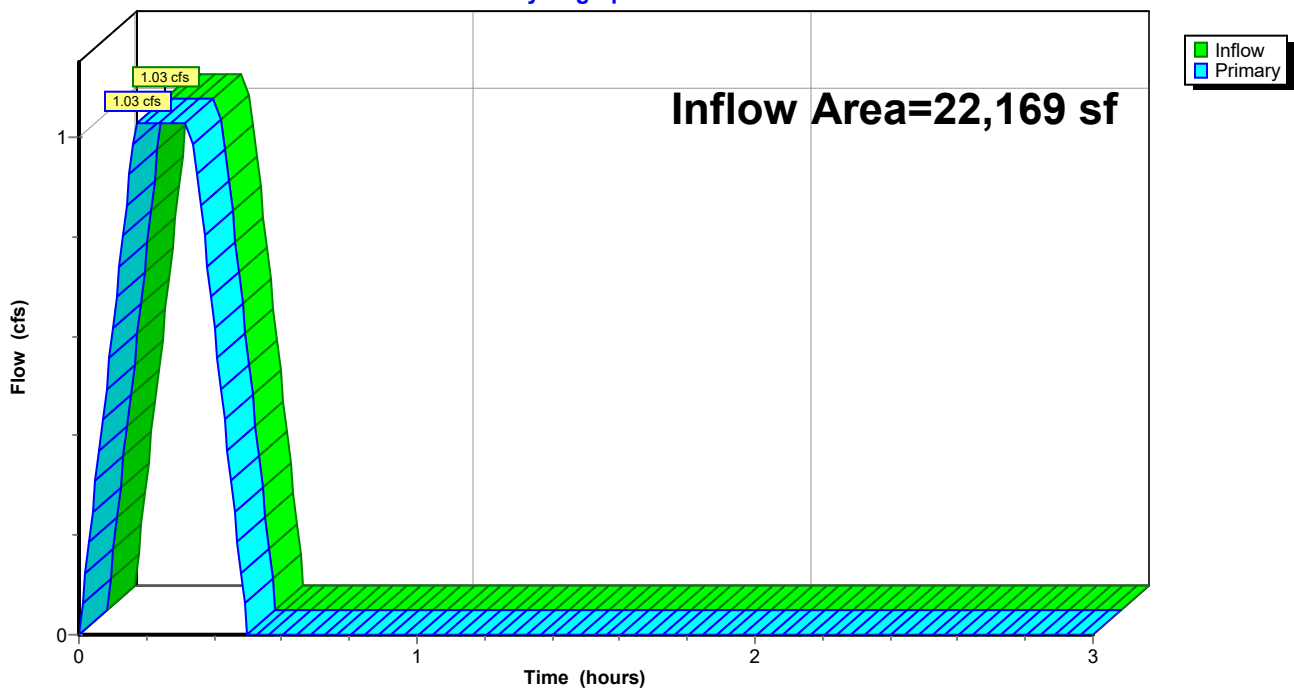

Summary for Pond CI-C1: CI - C1

Inflow Area = 20,337 sf, 69.83% Impervious, Inflow Depth = 0.81" for 2-yr event
Inflow = 1.15 cfs @ 0.09 hrs, Volume= 1,380 cf
Primary = 1.15 cfs @ 0.09 hrs, Volume= 1,380 cf, Atten= 0%, Lag= 0.0 min
Routed to Pond CI-C2 : CI - C2

Routing by Stor-Ind method, Time Span= 0.00-3.00 hrs, dt= 0.01 hrs

Pond CI-C1: CI - C1

Hydrograph

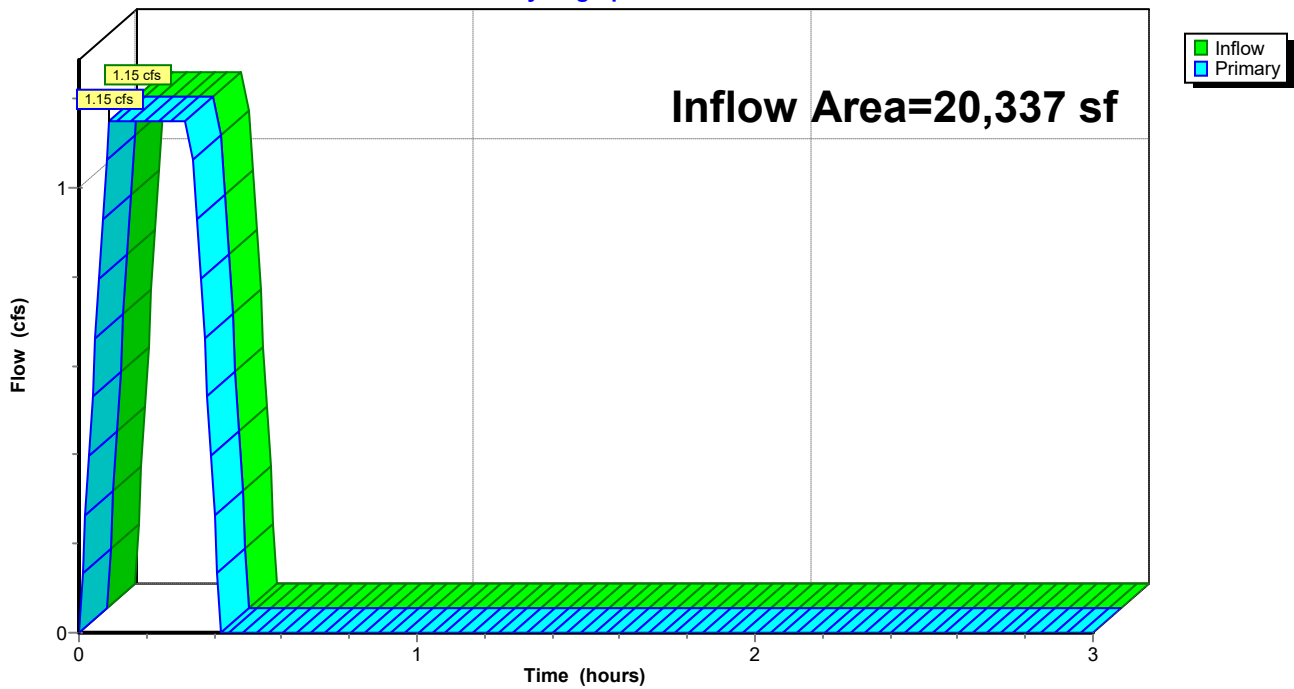

Summary for Pond CI-C2: CI - C2

Inflow Area = 54,676 sf, 67.97% Impervious, Inflow Depth = 0.81" for 2-yr event
Inflow = 3.07 cfs @ 0.09 hrs, Volume= 3,681 cf
Primary = 3.07 cfs @ 0.09 hrs, Volume= 3,681 cf, Atten= 0%, Lag= 0.0 min
Routed to Pond CI-C3 : CI - C3

Routing by Stor-Ind method, Time Span= 0.00-3.00 hrs, dt= 0.01 hrs

Pond CI-C2: CI - C2

Hydrograph

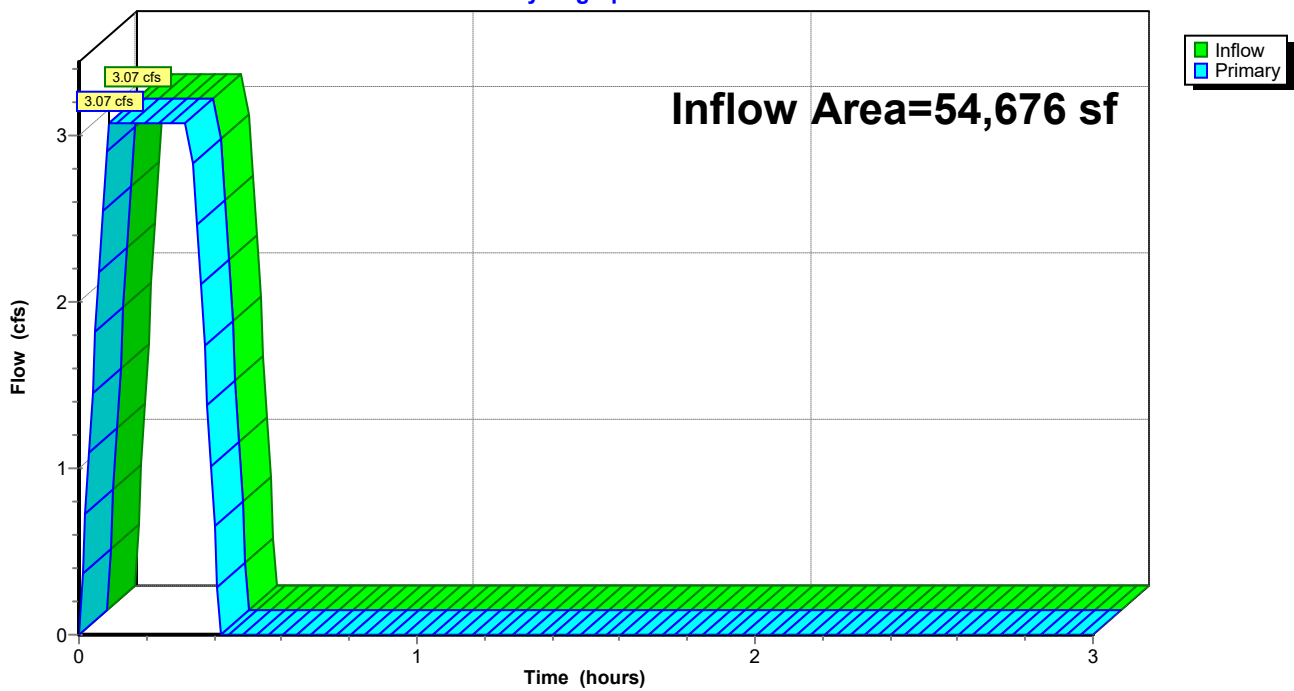

Summary for Pond CI-C3: CI - C3

Inflow Area = 69,531 sf, 63.12% Impervious, Inflow Depth = 0.78" for 2-yr event
Inflow = 3.77 cfs @ 0.09 hrs, Volume= 4,523 cf
Primary = 3.77 cfs @ 0.09 hrs, Volume= 4,523 cf, Atten= 0%, Lag= 0.0 min
Routed to Pond CI-C4 : CI - C4

Routing by Stor-Ind method, Time Span= 0.00-3.00 hrs, dt= 0.01 hrs

Pond CI-C3: CI - C3

Hydrograph

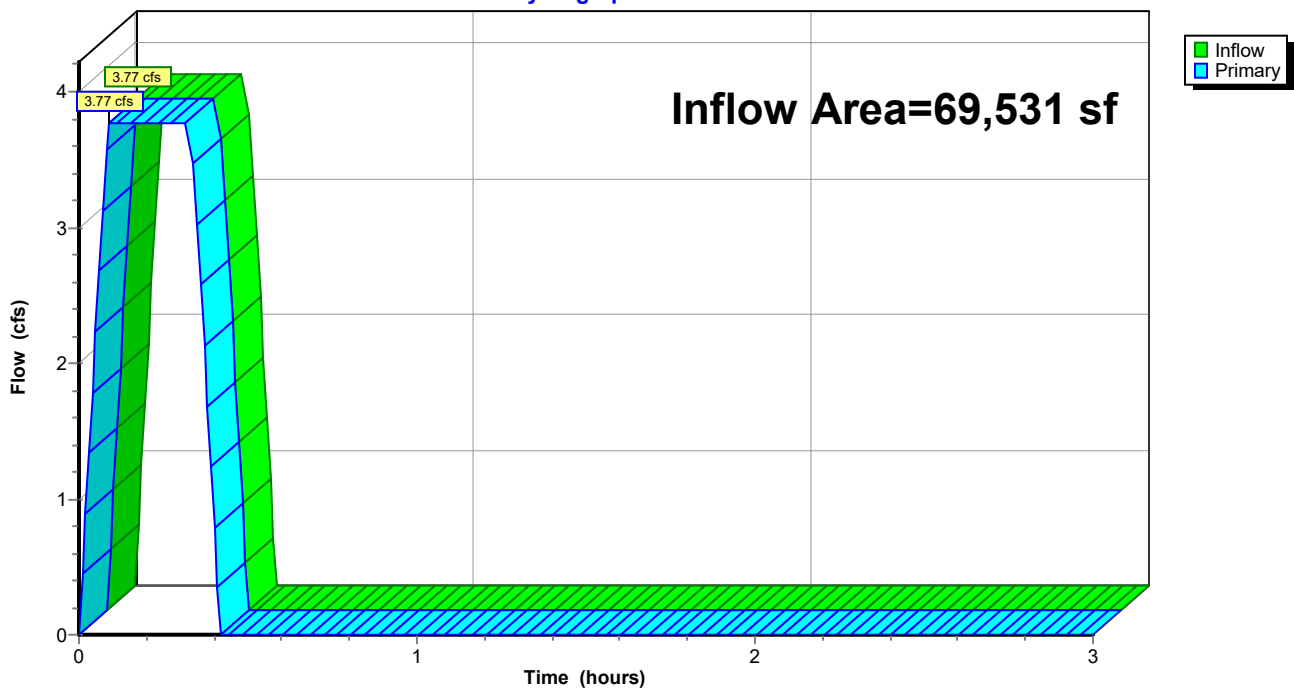

Summary for Pond CI-C4: CI - C4

Inflow Area = 76,226 sf, 64.22% Impervious, Inflow Depth = 0.79" for 2-yr event
Inflow = 4.17 cfs @ 0.10 hrs, Volume= 5,001 cf
Primary = 4.17 cfs @ 0.10 hrs, Volume= 5,001 cf, Atten= 0%, Lag= 0.0 min
Routed to Pond CI-C5 : CI - C5

Routing by Stor-Ind method, Time Span= 0.00-3.00 hrs, dt= 0.01 hrs

Pond CI-C4: CI - C4

Hydrograph

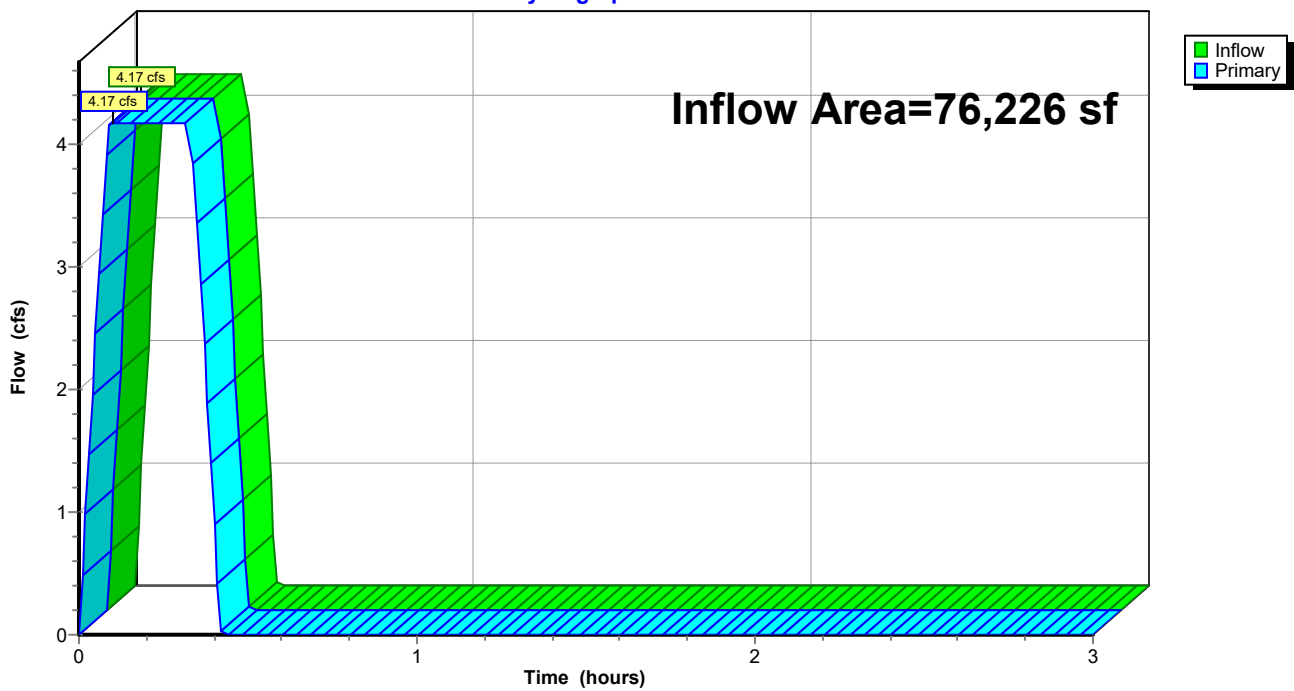

Summary for Pond CI-C5: CI - C5

Inflow Area = 79,061 sf, 65.50% Impervious, Inflow Depth = 0.79" for 2-yr event
Inflow = 4.36 cfs @ 0.10 hrs, Volume= 5,235 cf
Primary = 4.36 cfs @ 0.10 hrs, Volume= 5,235 cf, Atten= 0%, Lag= 0.0 min
Routed to Pond CI-C6 : CI - C6

Routing by Stor-Ind method, Time Span= 0.00-3.00 hrs, dt= 0.01 hrs

Pond CI-C5: CI - C5

Hydrograph

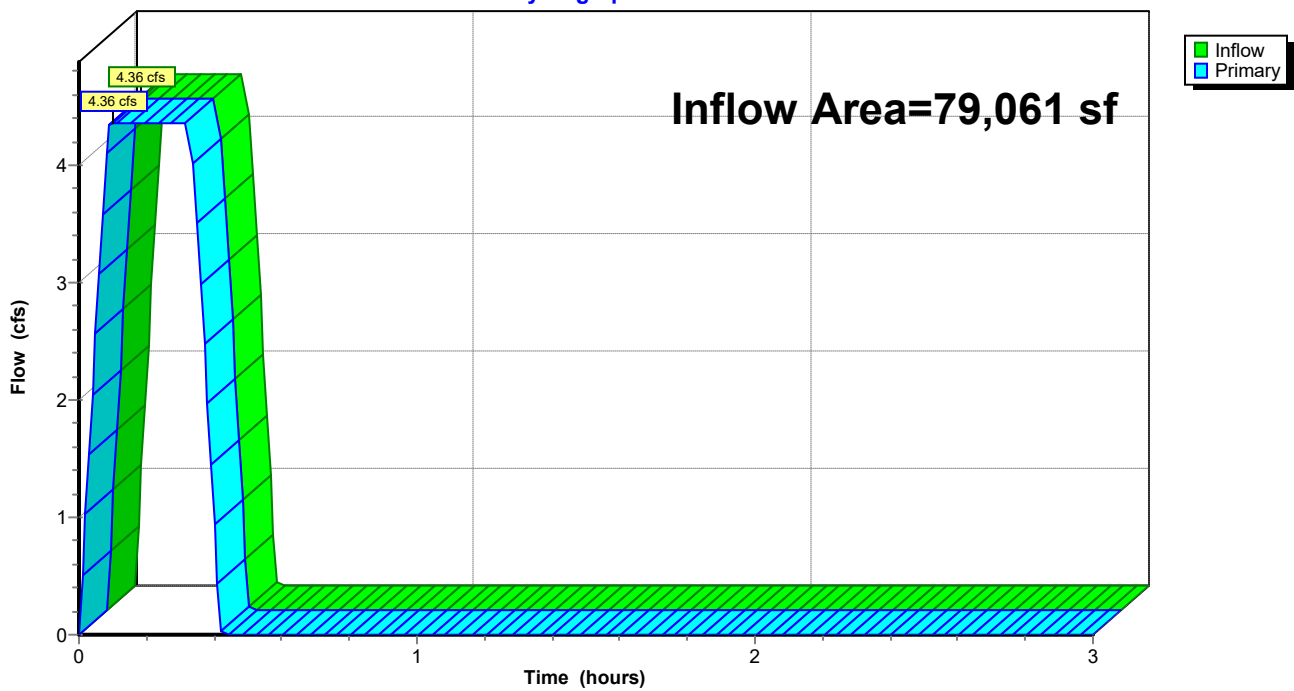

Summary for Pond CI-C6: CI - C6

Inflow Area = 96,023 sf, 66.95% Impervious, Inflow Depth = 0.80" for 2-yr event
Inflow = 5.35 cfs @ 0.10 hrs, Volume= 6,421 cf
Primary = 5.35 cfs @ 0.10 hrs, Volume= 6,421 cf, Atten= 0%, Lag= 0.0 min
Routed to Pond CI-C7 : CI - C7

Routing by Stor-Ind method, Time Span= 0.00-3.00 hrs, dt= 0.01 hrs

Pond CI-C6: CI - C6

Hydrograph

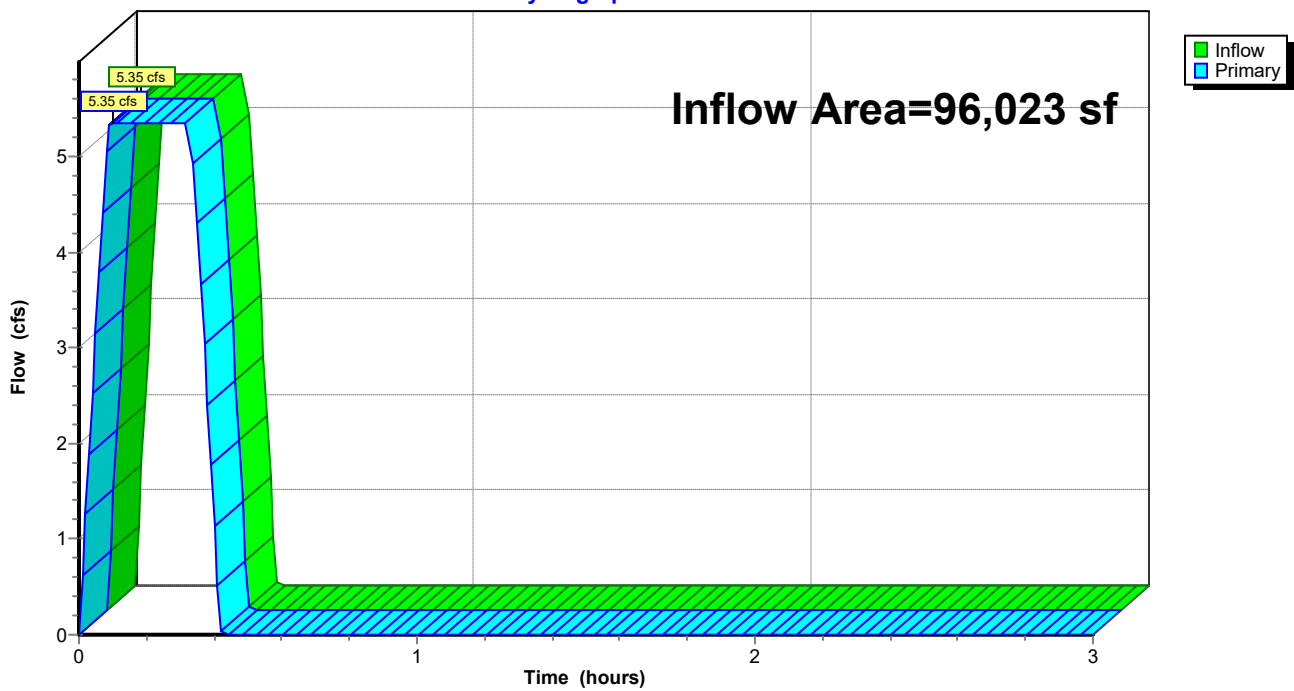

Summary for Pond CI-C7: CI - C7

Inflow Area = 133,272 sf, 67.70% Impervious, Inflow Depth = 0.81" for 2-yr event
Inflow = 7.48 cfs @ 0.10 hrs, Volume= 8,969 cf
Primary = 7.48 cfs @ 0.10 hrs, Volume= 8,969 cf, Atten= 0%, Lag= 0.0 min
Routed to Pond DP : Existing North Detention Pond

Routing by Stor-Ind method, Time Span= 0.00-3.00 hrs, dt= 0.01 hrs

Pond CI-C7: CI - C7

Hydrograph

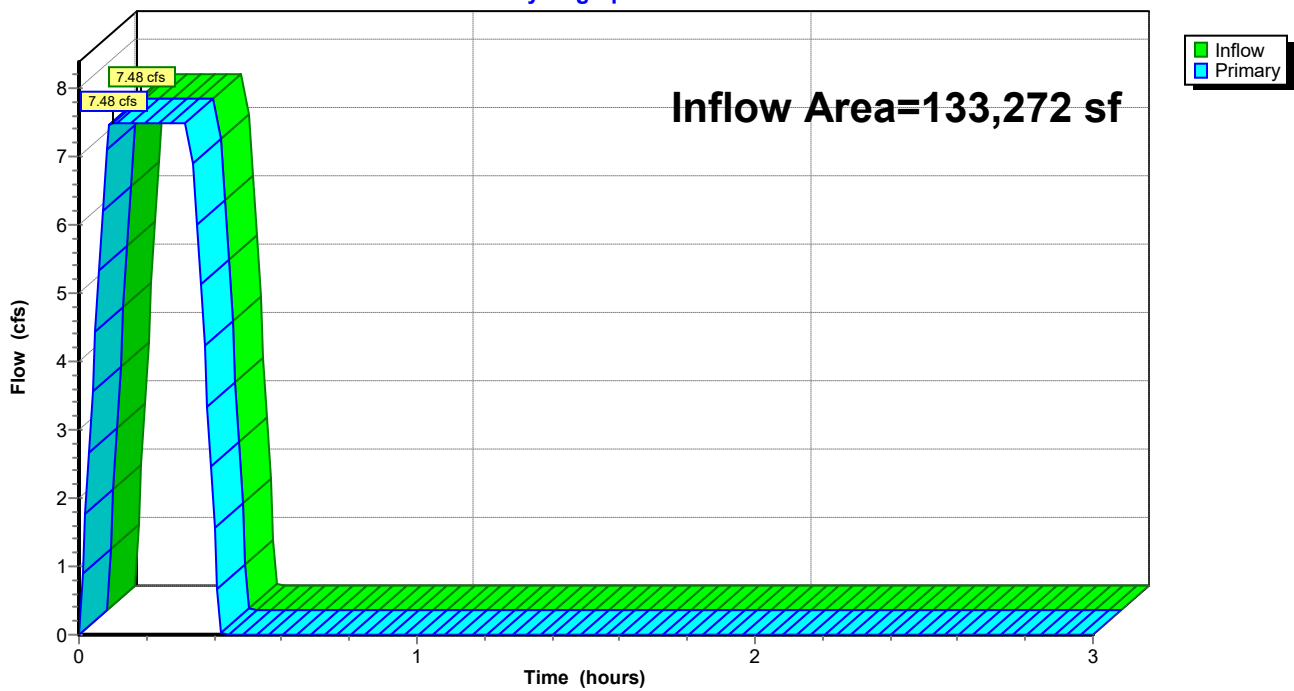

Summary for Pond CI-D1: CI - D1

Inflow Area = 1,597 sf, 100.00% Impervious, Inflow Depth = 0.99" for 2-yr event
Inflow = 0.11 cfs @ 0.09 hrs, Volume= 132 cf
Primary = 0.11 cfs @ 0.09 hrs, Volume= 132 cf, Atten= 0%, Lag= 0.0 min
Routed to Pond CI-D2 : CI - D2

Routing by Stor-Ind method, Time Span= 0.00-3.00 hrs, dt= 0.01 hrs

Pond CI-D1: CI - D1

Hydrograph

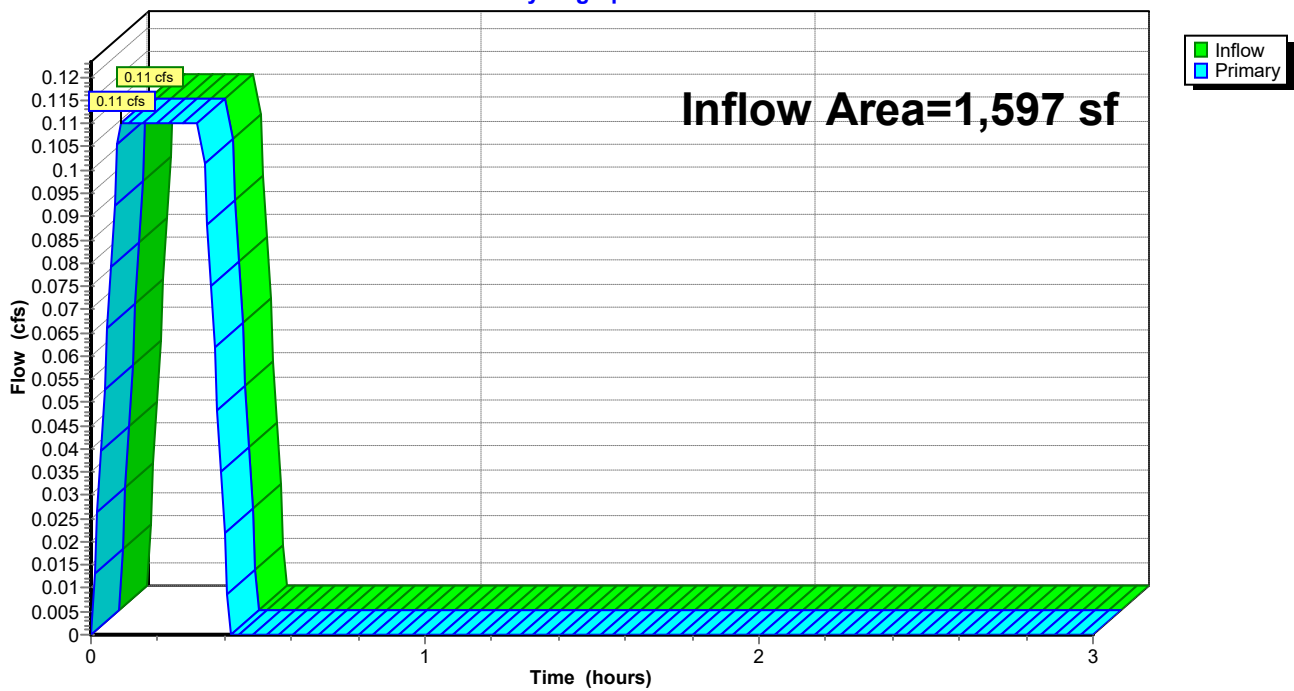

Summary for Pond CI-D2: CI - D2

Inflow Area = 3,145 sf, 100.00% Impervious, Inflow Depth = 0.99" for 2-yr event
Inflow = 0.22 cfs @ 0.09 hrs, Volume= 260 cf
Primary = 0.22 cfs @ 0.09 hrs, Volume= 260 cf, Atten= 0%, Lag= 0.0 min
Routed to Pond CI-C6 : CI - C6

Routing by Stor-Ind method, Time Span= 0.00-3.00 hrs, dt= 0.01 hrs

Pond CI-D2: CI - D2

Hydrograph

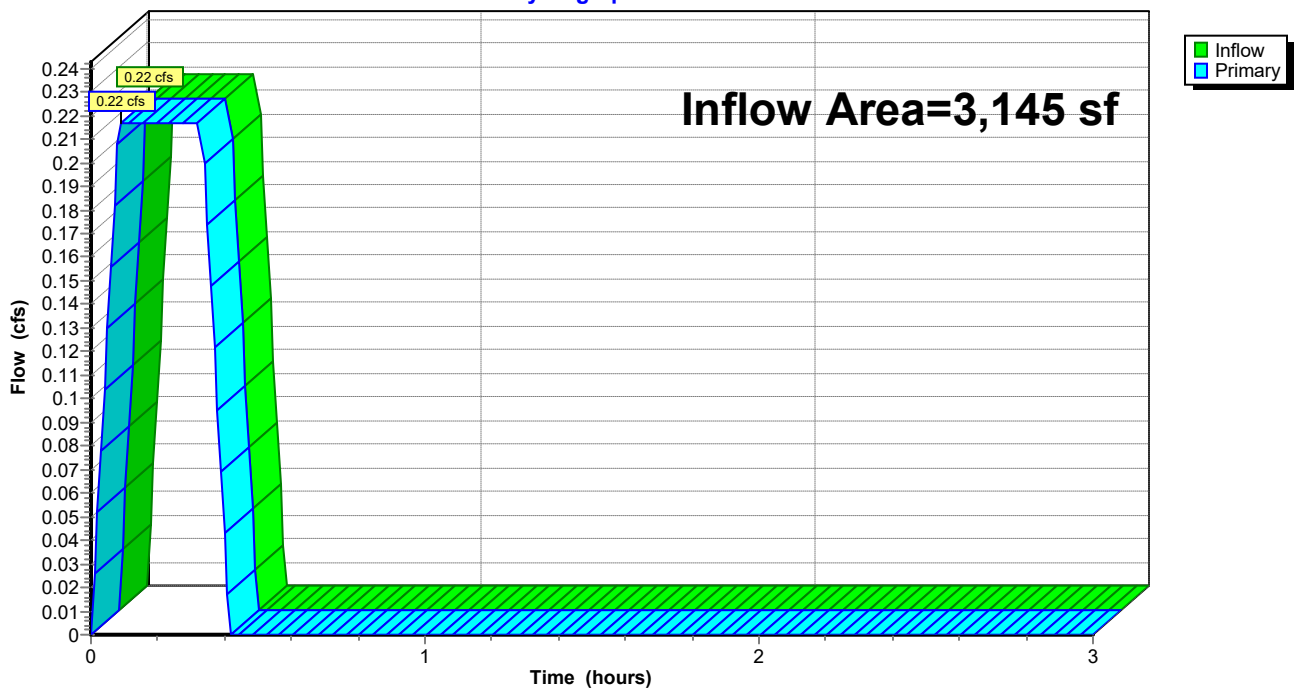

Summary for Pond CI-E1: CI - E1

Inflow Area = 5,408 sf, 77.35% Impervious, Inflow Depth = 0.87" for 2-yr event
Inflow = 0.33 cfs @ 0.09 hrs, Volume= 391 cf
Primary = 0.33 cfs @ 0.09 hrs, Volume= 391 cf, Atten= 0%, Lag= 0.0 min
Routed to Pond CI-E2 : CI - E2

Routing by Stor-Ind method, Time Span= 0.00-3.00 hrs, dt= 0.01 hrs

Pond CI-E1: CI - E1

Hydrograph

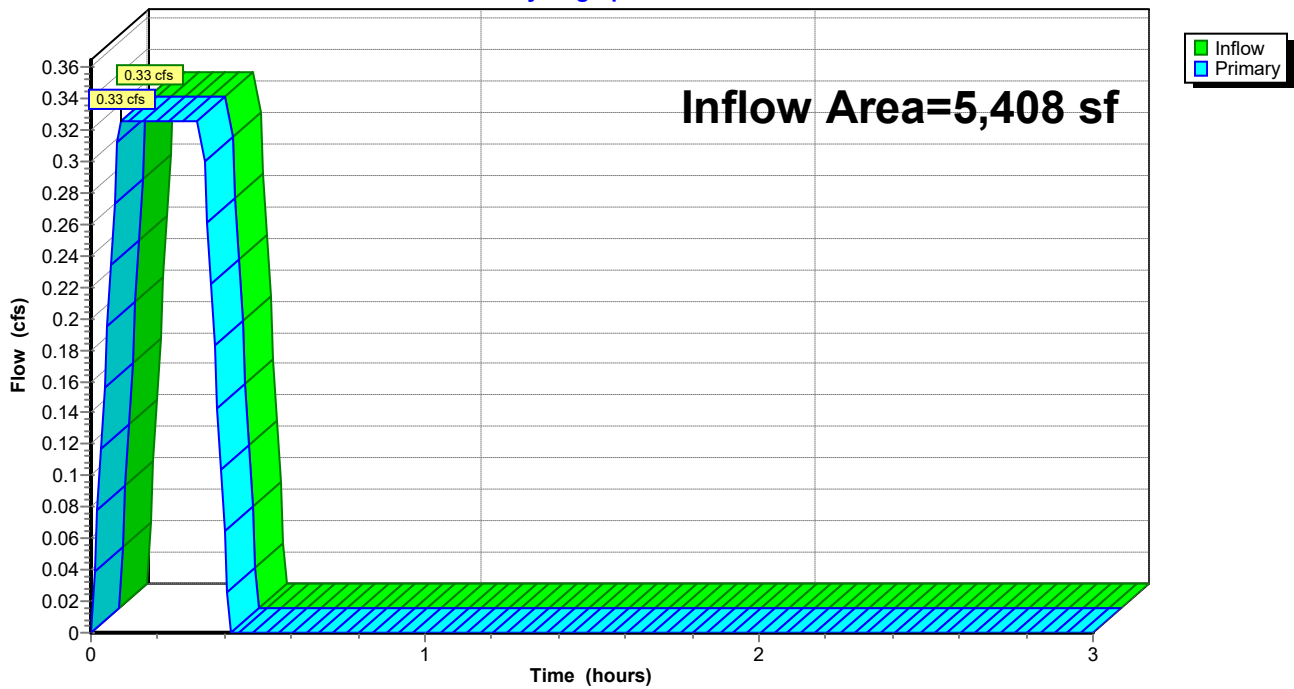

Summary for Pond CI-E2: CI - E2

Inflow Area = 11,591 sf, 64.62% Impervious, Inflow Depth = 0.79" for 2-yr event
Inflow = 0.64 cfs @ 0.09 hrs, Volume= 762 cf
Primary = 0.64 cfs @ 0.09 hrs, Volume= 762 cf, Atten= 0%, Lag= 0.0 min
Routed to Pond CI-C7 : CI - C7

Routing by Stor-Ind method, Time Span= 0.00-3.00 hrs, dt= 0.01 hrs

Pond CI-E2: CI - E2

Hydrograph

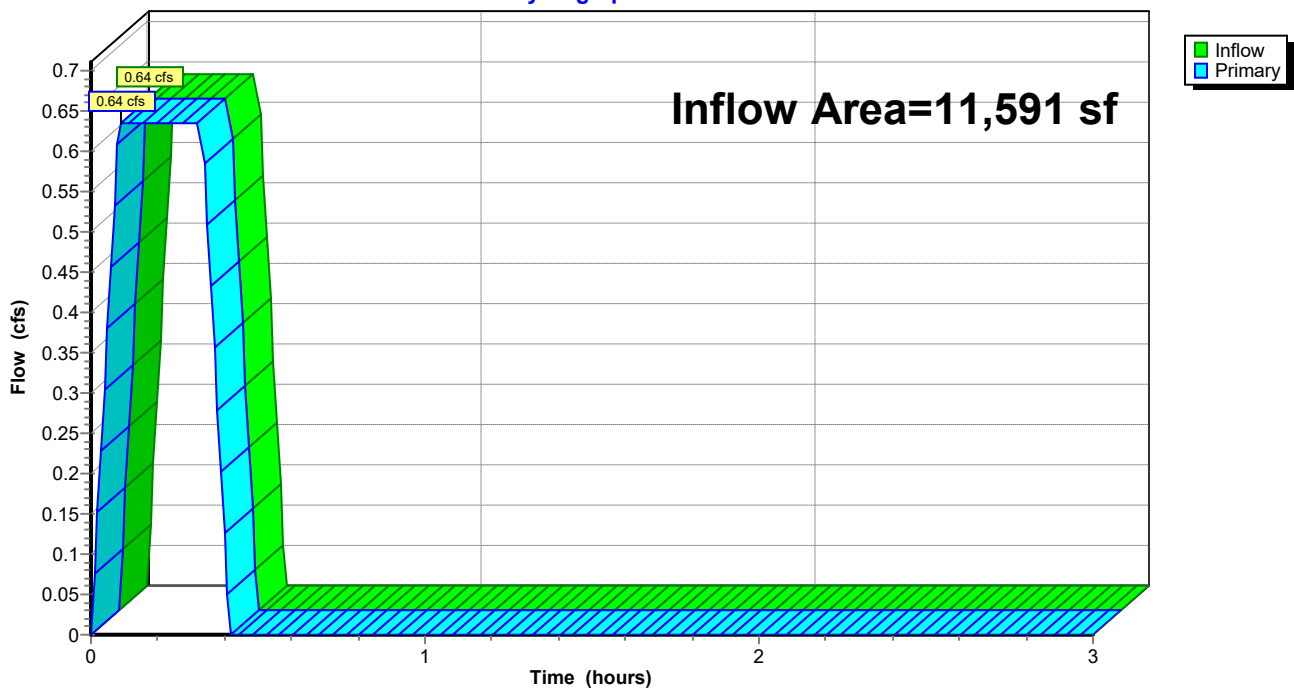

Goddard

AR - Little Rock 2-yr Duration=20 min, Inten=3.13 in/hr

Prepared by Phillip Lewis Engineering

Printed 3/25/2026

HydroCAD® 10.20-5c s/n 12520 © 2023 HydroCAD Software Solutions LLC

Summary for Pond DP: Existing North Detention Pond

Inflow Area = 322,783 sf, 53.09% Impervious, Inflow Depth = 0.73" for 2-yr event
 Inflow = 16.44 cfs @ 0.27 hrs, Volume= 19,723 cf
 Outflow = 8.58 cfs @ 0.38 hrs, Volume= 19,723 cf, Atten= 48%, Lag= 6.7 min
 Primary = 8.58 cfs @ 0.38 hrs, Volume= 19,723 cf
 Routed to Link FINAL : APPROX DISCHARGE

Routing by Stor-Ind method, Time Span= 0.00-3.00 hrs, dt= 0.01 hrs
 Peak Elev= 382.69' @ 0.38 hrs Storage= 10,893 cf

Plug-Flow detention time= 15.8 min calculated for 19,723 cf (100% of inflow)
 Center-of-Mass det. time= 15.7 min (29.2 - 13.5)

Volume	Invert	Avail.Storage	Storage Description
#1	381.17'	72,742 cf	Custom Stage Data Listed below

Elevation (feet)	Inc.Store (cubic-feet)	Cum.Store (cubic-feet)
381.17	0	0
381.50	200	200
382.00	1,825	2,025
382.50	5,265	7,290
383.00	9,300	16,590
383.50	13,733	30,323
384.00	18,578	48,901
384.50	23,841	72,742

Device	Routing	Invert	Outlet Devices
#1	Primary	384.16'	5.0' long Sharp-Crested Rectangular Weir 2 End Contraction(s)
#2	Primary	381.17'	1.7' long Sharp-Crested Rectangular Weir 2 End Contraction(s)

Primary OutFlow Max=8.58 cfs @ 0.38 hrs HW=382.69' (Free Discharge)

↑ **1=Sharp-Crested Rectangular Weir** (Controls 0.00 cfs)

└ **2=Sharp-Crested Rectangular Weir** (Weir Controls 8.58 cfs @ 4.04 fps)

Pond DP: Existing North Detention Pond

Hydrograph

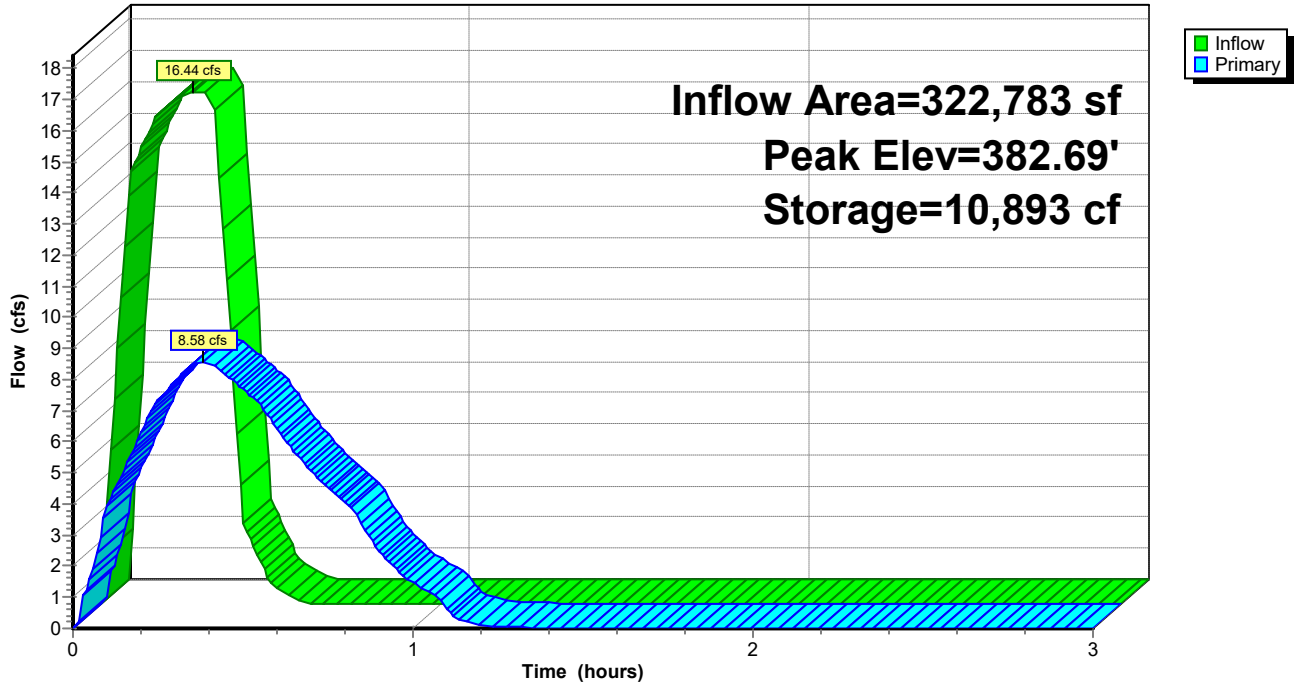

Summary for Pond JB-A2: JB - A2

Inflow Area = 50,937 sf, 59.76% Impervious, Inflow Depth = 0.81" for 2-yr event
Inflow = 2.86 cfs @ 0.17 hrs, Volume= 3,427 cf
Primary = 2.86 cfs @ 0.17 hrs, Volume= 3,427 cf, Atten= 0%, Lag= 0.0 min
Routed to Pond CI-A3 : CI - A3

Routing by Stor-Ind method, Time Span= 0.00-3.00 hrs, dt= 0.01 hrs

Pond JB-A2: JB - A2

Hydrograph

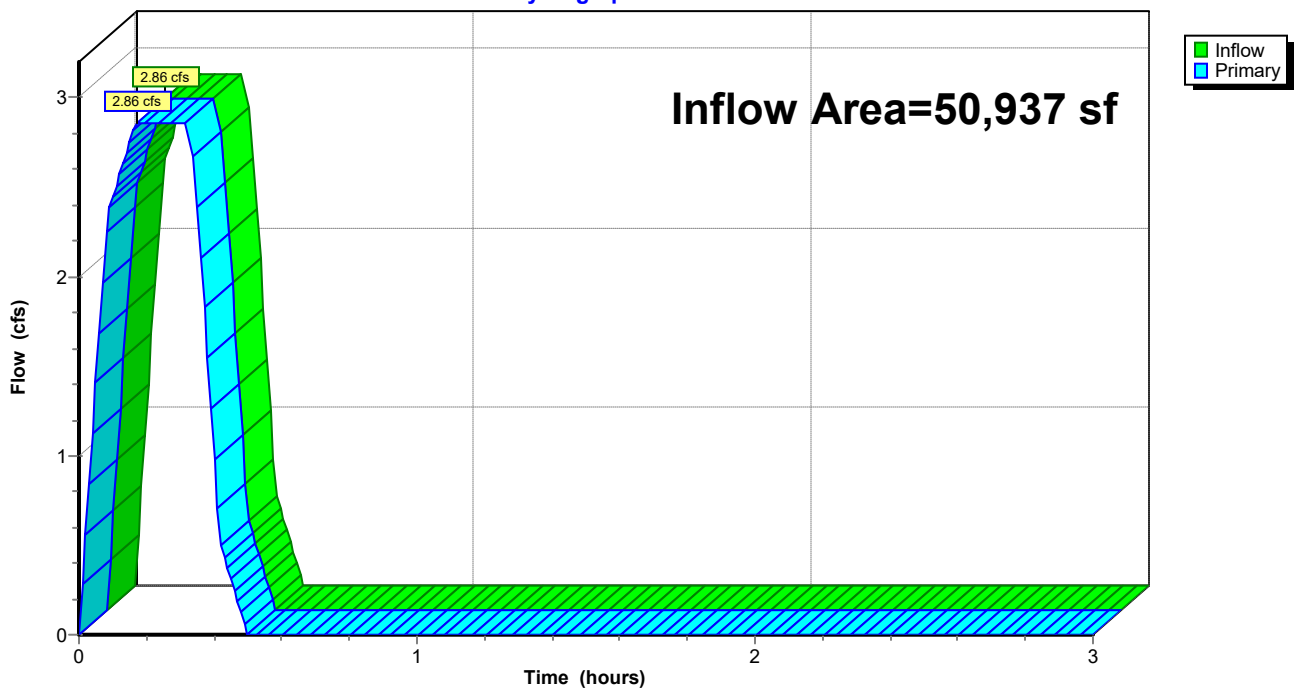

Summary for Link FINAL: APPROX DISCHARGE

Inflow Area = 509,184 sf, 38.62% Impervious, Inflow Depth = 0.67" for 2-yr event
Inflow = 15.57 cfs @ 0.33 hrs, Volume= 28,475 cf
Primary = 15.57 cfs @ 0.33 hrs, Volume= 28,475 cf, Atten= 0%, Lag= 0.0 min

Primary outflow = Inflow, Time Span= 0.00-3.00 hrs, dt= 0.01 hrs

Link FINAL: APPROX DISCHARGE

Hydrograph

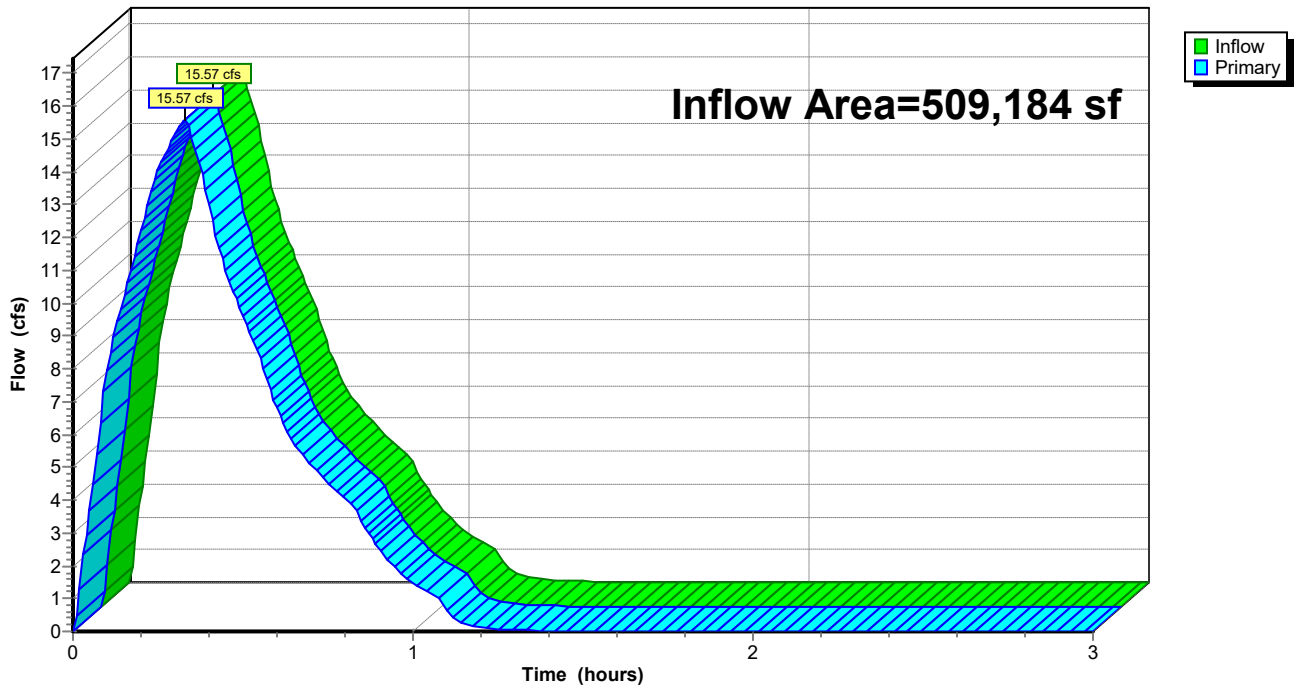

Goddard

Prepared by Phillip Lewis Engineering

HydroCAD® 10.20-5c s/n 12520 © 2023 HydroCAD Software Solutions LLC

AR - Little Rock 5-yr Duration=20 min, Inten=3.73 in/hr

Printed 3/25/2026

Summary for Subcatchment B1: Drainage Basin B1

Runoff = 3.42 cfs @ 0.31 hrs, Volume= 4,108 cf, Depth= 0.66"

Routed to Link FINAL : APPROX DISCHARGE

Runoff by Rational method, Rise/Fall=1.0/1.0 xTc, Time Span= 0.00-3.00 hrs, dt= 0.01 hrs

AR - Little Rock 5-yr Duration=20 min, Inten=3.73 in/hr

Area (sf)	C	Description
9,241	0.51	Sod Yard
602	0.95	Paving, Sidewalks
64,924	0.53	Undeveloped
74,767	0.53	Weighted Average
74,165		99.19% Pervious Area
602		0.81% Impervious Area

Tc (min)	Length (feet)	Slope (ft/ft)	Velocity (ft/sec)	Capacity (cfs)	Description
0.1	6	0.0180	0.86		Sheet Flow, Sheet Flow Smooth surfaces n= 0.011 P2= 4.19"
2.6	25	0.1920	0.16		Sheet Flow, Sheet Flow Grass: Bermuda n= 0.410 P2= 4.19"
11.9	75	0.0370	0.11		Sheet Flow, Sheet Flow Grass: Bermuda n= 0.410 P2= 4.19"
0.7	58	0.0370	1.35		Shallow Concentrated Flow, Concentrated Flow Short Grass Pasture Kv= 7.0 fps
1.6	141	0.0420	1.43		Shallow Concentrated Flow, Concentrated Flow Short Grass Pasture Kv= 7.0 fps
0.7	60	0.0400	1.40		Shallow Concentrated Flow, Concentrated Flow Short Grass Pasture Kv= 7.0 fps
0.9	77	0.0420	1.43		Shallow Concentrated Flow, Concentrated Flow Short Grass Pasture Kv= 7.0 fps
18.5	442	Total			

Subcatchment B1: Drainage Basin B1

Hydrograph

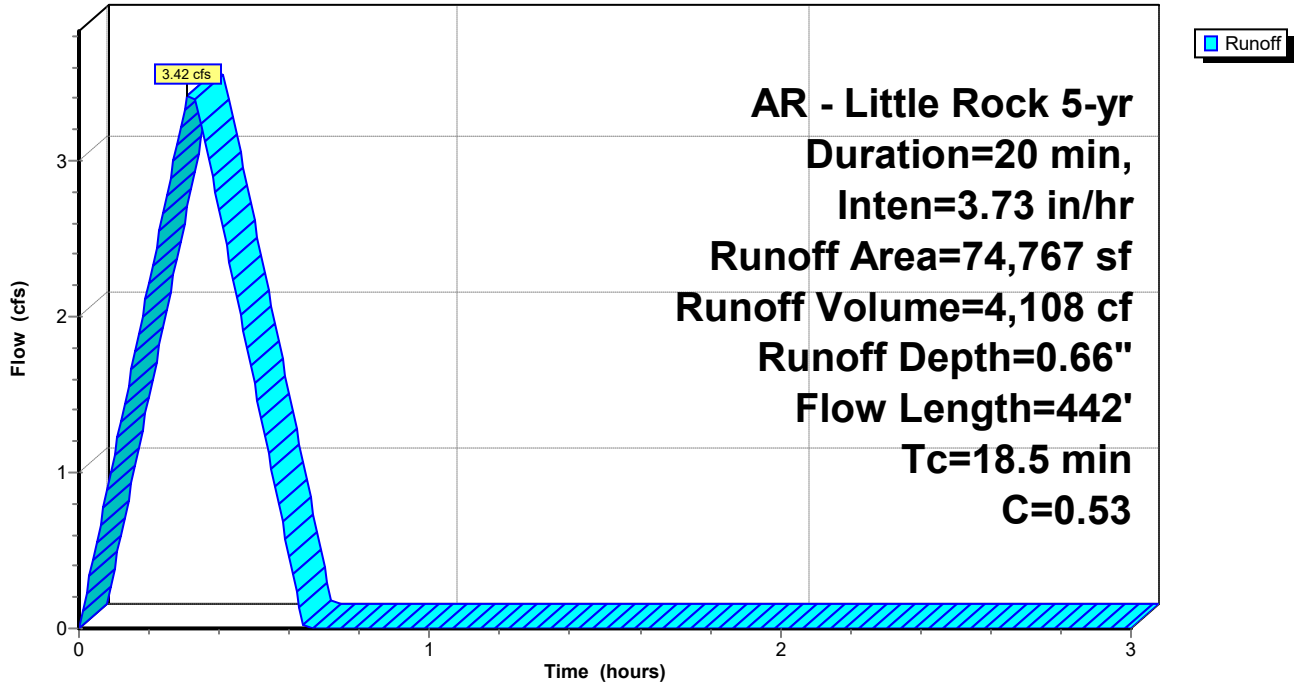

Goddard

Prepared by Phillip Lewis Engineering

HydroCAD® 10.20-5c s/n 12520 © 2023 HydroCAD Software Solutions LLC

AR - Little Rock 5-yr Duration=20 min, Inten=3.73 in/hr

Printed 3/25/2026

Summary for Subcatchment B2: Drainage Basin B2

Runoff = 0.30 cfs @ 0.10 hrs, Volume= 364 cf, Depth= 0.65"
 Routed to Link FINAL : APPROX DISCHARGE

Runoff by Rational method, Rise/Fall=1.0/1.0 xTc, Time Span= 0.00-3.00 hrs, dt= 0.01 hrs
 AR - Little Rock 5-yr Duration=20 min, Inten=3.73 in/hr

Area (sf)	C	Description
6,595	0.51	Sod Yard
167	0.95	Paving, Sidewalks
6,762	0.52	Weighted Average
6,595		97.53% Pervious Area
167		2.47% Impervious Area

Tc (min)	Length (feet)	Slope (ft/ft)	Velocity (ft/sec)	Capacity (cfs)	Description
0.1	6	0.0180	0.86		Sheet Flow, Sheet Flow Smooth surfaces n= 0.011 P2= 4.19"
5.7	55	0.1240	0.16		Sheet Flow, Sheet Flow Grass: Bermuda n= 0.410 P2= 4.19"
5.8	61	Total			

Subcatchment B2: Drainage Basin B2

Hydrograph

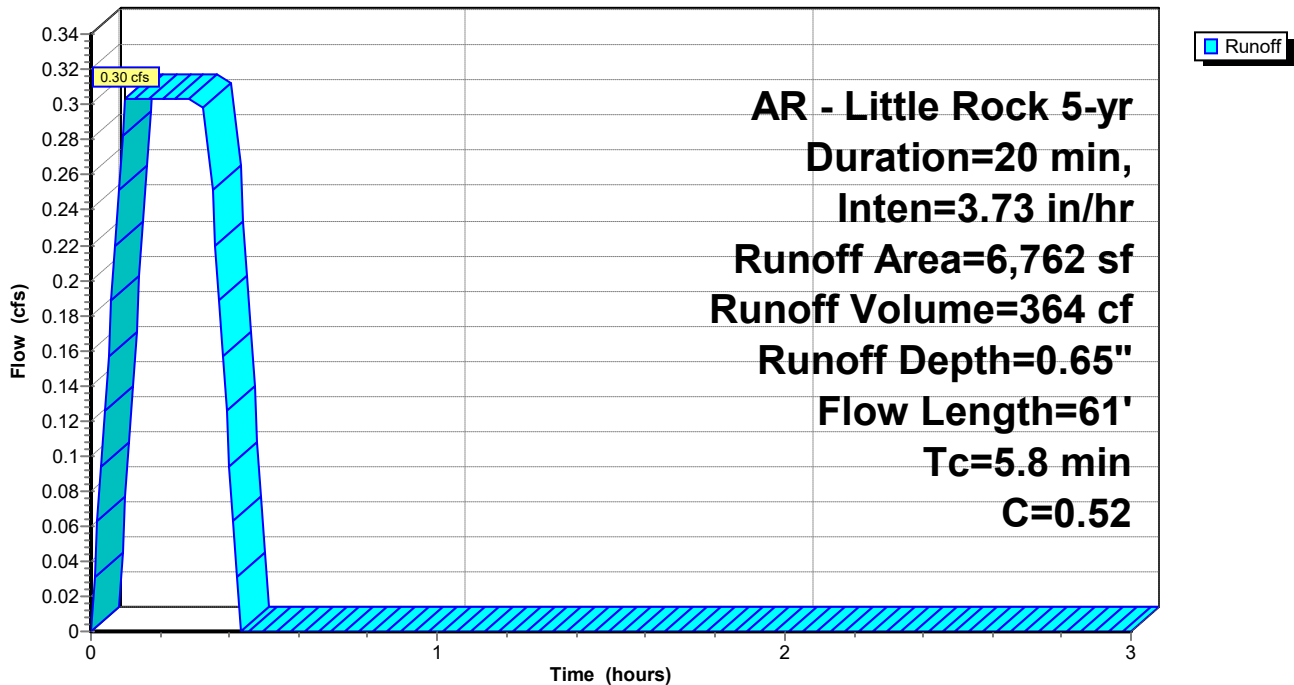

Goddard

Prepared by Phillip Lewis Engineering

HydroCAD® 10.20-5c s/n 12520 © 2023 HydroCAD Software Solutions LLC

AR - Little Rock 5-yr Duration=20 min, Inten=3.73 in/hr

Printed 3/25/2026

Summary for Subcatchment B3: Drainage Basin B3

Runoff = 2.01 cfs @ 0.26 hrs, Volume= 2,415 cf, Depth= 0.87"
 Routed to Link FINAL : APPROX DISCHARGE

Runoff by Rational method, Rise/Fall=1.0/1.0 xTc, Time Span= 0.00-3.00 hrs, dt= 0.01 hrs
 AR - Little Rock 5-yr Duration=20 min, Inten=3.73 in/hr

Area (sf)	C	Description
18,730	0.51	Sod Yard
14,559	0.95	Paving, Sidewalks
33,289	0.70	Weighted Average
18,730		56.26% Pervious Area
14,559		43.74% Impervious Area

Tc (min)	Length (feet)	Slope (ft/ft)	Velocity (ft/sec)	Capacity (cfs)	Description
4.9	47	0.1300	0.16		Sheet Flow, Sheet Flow Grass: Bermuda n= 0.410 P2= 4.19"
6.9	53	0.0730	0.13		Sheet Flow, Sheet Flow Grass: Bermuda n= 0.410 P2= 4.19"
0.0	11	0.0940	4.60		Shallow Concentrated Flow, Concentrated Flow Grassed Waterway Kv= 15.0 fps
0.4	53	0.0120	2.22		Shallow Concentrated Flow, Concentrated Flow Paved Kv= 20.3 fps
0.5	59	0.0100	2.03		Shallow Concentrated Flow, Concentrated Flow Paved Kv= 20.3 fps
0.5	47	0.0070	1.70		Shallow Concentrated Flow, Concentrated Flow Paved Kv= 20.3 fps
0.5	56	0.0070	1.70		Shallow Concentrated Flow, Concentrated Flow Paved Kv= 20.3 fps
0.2	38	0.0160	2.57		Shallow Concentrated Flow, Concentrated Flow Paved Kv= 20.3 fps
0.2	30	0.0190	2.80		Shallow Concentrated Flow, Concentrated Flow Paved Kv= 20.3 fps
1.3	216	0.0190	2.80		Shallow Concentrated Flow, Concentrated Flow Paved Kv= 20.3 fps
15.4	610	Total			

Subcatchment B3: Drainage Basin B3

Hydrograph

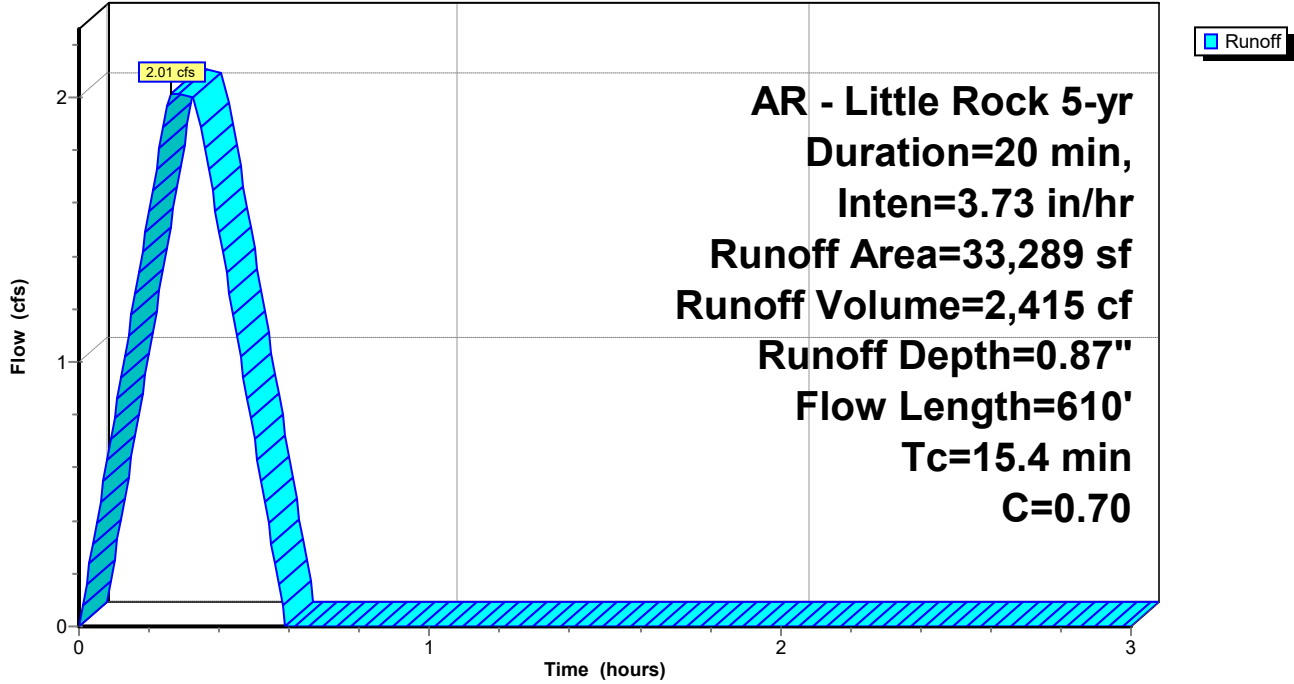

Goddard

Prepared by Phillip Lewis Engineering

HydroCAD® 10.20-5c s/n 12520 © 2023 HydroCAD Software Solutions LLC

AR - Little Rock 5-yr Duration=20 min, Inten=3.73 in/hr

Printed 3/25/2026

Summary for Subcatchment B4: Drainage Basin B4

Runoff = 1.41 cfs @ 0.09 hrs, Volume= 1,697 cf, Depth= 1.04"
 Routed to Pond CI-A1 : CI - A1

Runoff by Rational method, Rise/Fall=1.0/1.0 xTc, Time Span= 0.00-3.00 hrs, dt= 0.01 hrs
 AR - Little Rock 5-yr Duration=20 min, Inten=3.73 in/hr

Area (sf)	C	Description
4,916	0.51	Sod Yard
14,577	0.95	Paving, Sidewalks
19,493	0.84	Weighted Average
4,916		25.22% Pervious Area
14,577		74.78% Impervious Area

Tc (min)	Length (feet)	Slope (ft/ft)	Velocity (ft/sec)	Capacity (cfs)	Description
0.4	31	0.0230	1.32		Sheet Flow, Sheet Flow Smooth surfaces n= 0.011 P2= 4.19"
0.2	18	0.0250	1.22		Sheet Flow, Sheet Flow Smooth surfaces n= 0.011 P2= 4.19"
0.3	28	0.0450	1.69		Sheet Flow, Sheet Flow Smooth surfaces n= 0.011 P2= 4.19"
0.4	72	0.0250	3.21		Shallow Concentrated Flow, Concentrated Flow Paved Kv= 20.3 fps
0.1	18	0.0170	2.65		Shallow Concentrated Flow, Concentrated Flow Paved Kv= 20.3 fps
0.3	51	0.0170	2.65		Shallow Concentrated Flow, Concentrated Flow Paved Kv= 20.3 fps
0.1	16	0.0170	2.65		Shallow Concentrated Flow, Concentrated Flow Paved Kv= 20.3 fps
0.0	8	0.0430	4.21		Shallow Concentrated Flow, Concentrated Flow Paved Kv= 20.3 fps
0.0	7	0.0580	4.89		Shallow Concentrated Flow, Concentrated Flow Paved Kv= 20.3 fps
3.2					Direct Entry, Overland Concentrated Flow (Min)
5.0	249	Total			

Subcatchment B4: Drainage Basin B4

Hydrograph

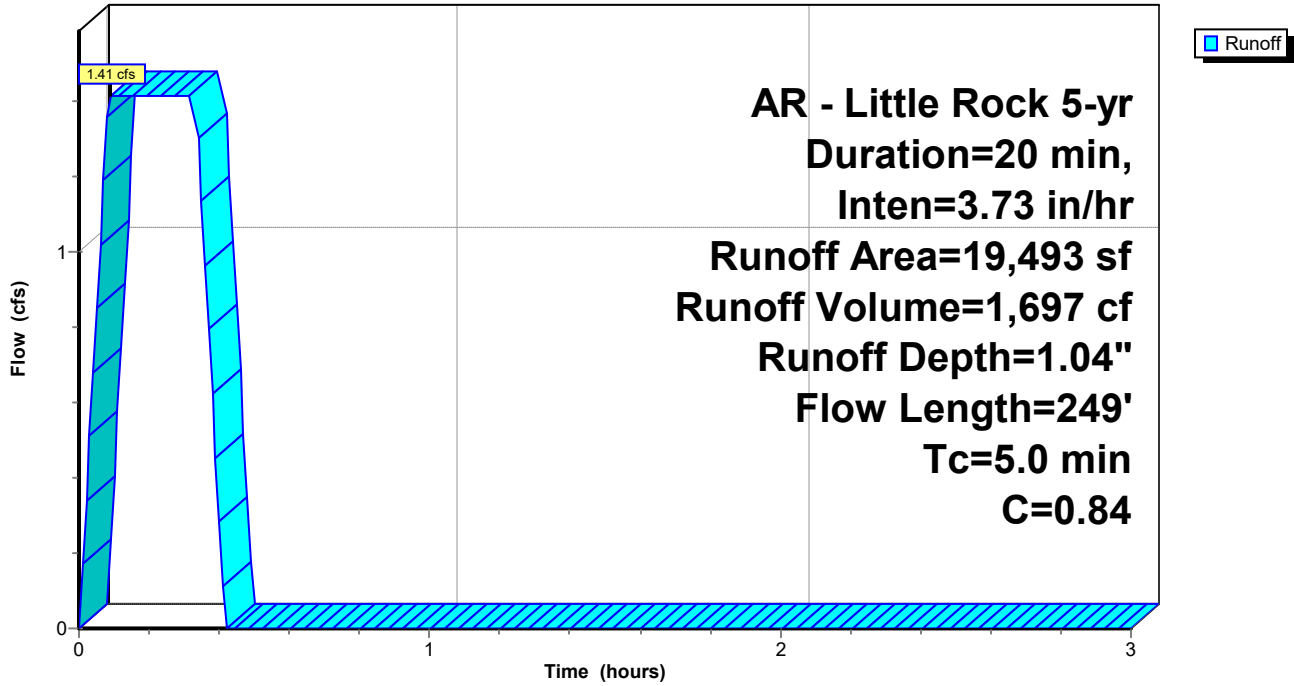

Summary for Subcatchment B5: Drainage Basin B5

Runoff = 0.76 cfs @ 0.09 hrs, Volume= 913 cf, Depth= 1.18"
 Routed to Pond JB-A2 : JB - A2

Runoff by Rational method, Rise/Fall=1.0/1.0 xTc, Time Span= 0.00-3.00 hrs, dt= 0.01 hrs
 AR - Little Rock 5-yr Duration=20 min, Inten=3.73 in/hr

Area (sf)	C	Description
9,275	0.95	Roof
9,275		100.00% Impervious Area

Tc (min)	Length (feet)	Slope (ft/ft)	Velocity (ft/sec)	Capacity (cfs)	Description
5.0					Direct Entry, Concentrated Flow (Min)

Subcatchment B5: Drainage Basin B5

Hydrograph

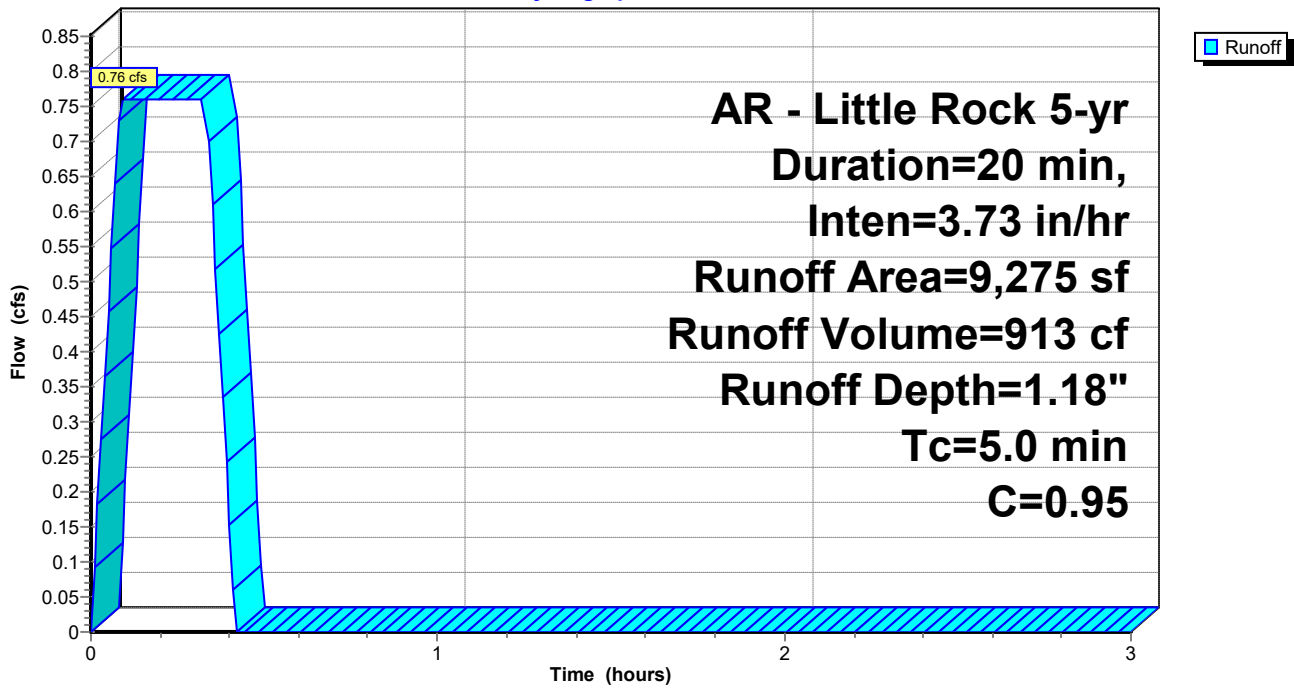

Goddard

Prepared by Phillip Lewis Engineering

HydroCAD® 10.20-5c s/n 12520 © 2023 HydroCAD Software Solutions LLC

AR - Little Rock 5-yr Duration=20 min, Inten=3.73 in/hr

Printed 3/25/2026

Summary for Subcatchment B6: Drainage Basin B6

Runoff = 0.15 cfs @ 0.09 hrs, Volume= 186 cf, Depth= 1.18"
 Routed to Pond CI-A3 : CI - A3

Runoff by Rational method, Rise/Fall=1.0/1.0 xTc, Time Span= 0.00-3.00 hrs, dt= 0.01 hrs
 AR - Little Rock 5-yr Duration=20 min, Inten=3.73 in/hr

Area (sf)	C	Description
0	0.51	Sod Yard
1,887	0.95	Paving, Sidewalks
1,887	0.95	Weighted Average
1,887		100.00% Impervious Area

Tc (min)	Length (feet)	Slope (ft/ft)	Velocity (ft/sec)	Capacity (cfs)	Description
0.4	31	0.0230	1.32		Sheet Flow, Sheet Flow Smooth surfaces n= 0.011 P2= 4.19"
0.2	18	0.0250	1.22		Sheet Flow, Sheet Flow Smooth surfaces n= 0.011 P2= 4.19"
0.4	30	0.0240	1.33		Sheet Flow, Sheet Flow Smooth surfaces n= 0.011 P2= 4.19"
0.0	13	0.0860	5.95		Shallow Concentrated Flow, Concentrated Flow Paved Kv= 20.3 fps
4.0	415		1.73		Direct Entry, Overland Concentrated Flow (Min)
5.0	507	Total			

Subcatchment B6: Drainage Basin B6

Hydrograph

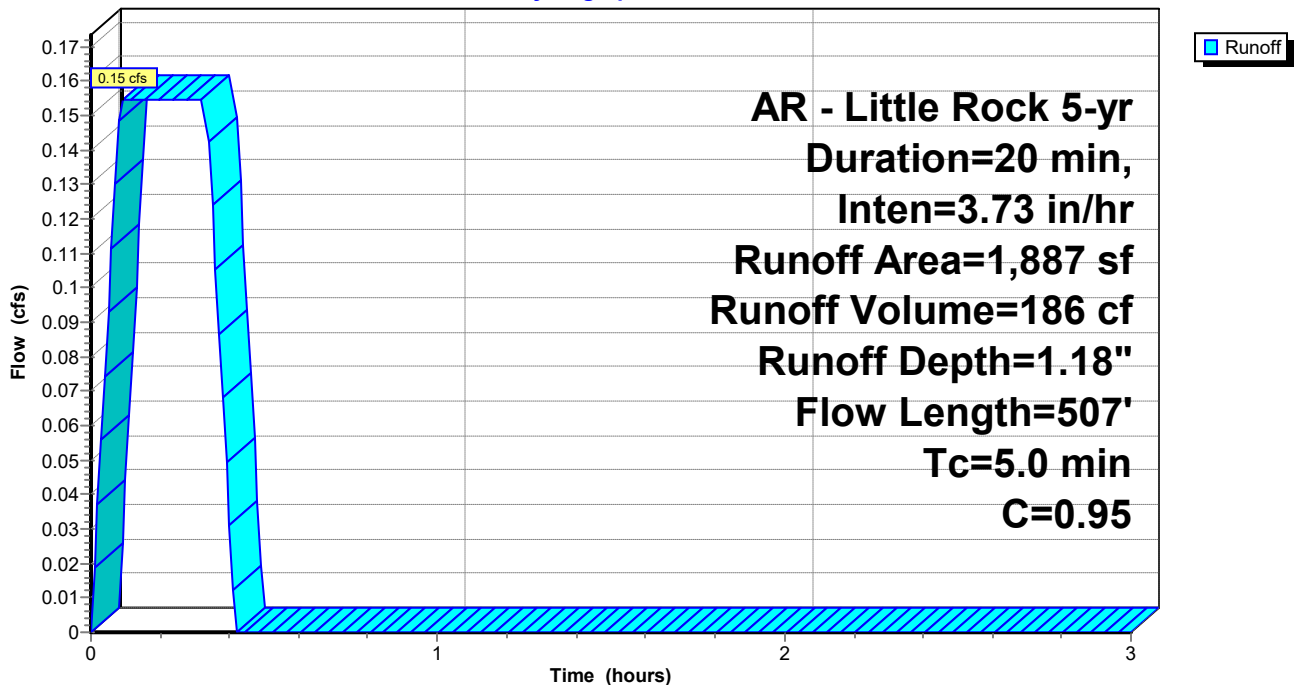

Goddard

Prepared by Phillip Lewis Engineering

HydroCAD® 10.20-5c s/n 12520 © 2023 HydroCAD Software Solutions LLC

AR - Little Rock 5-yr Duration=20 min, Inten=3.73 in/hr

Printed 3/25/2026

Summary for Subcatchment B7: Drainage Basin B7

Runoff = 1.23 cfs @ 0.17 hrs, Volume= 1,470 cf, Depth= 0.80"
 Routed to Pond CI-B2 : CI - B2

Runoff by Rational method, Rise/Fall=1.0/1.0 xTc, Time Span= 0.00-3.00 hrs, dt= 0.01 hrs
 AR - Little Rock 5-yr Duration=20 min, Inten=3.73 in/hr

Area (sf)	C	Description
15,580	0.51	Sod Yard
6,589	0.95	Paving, Sidewalks
22,169	0.64	Weighted Average
15,580		70.28% Pervious Area
6,589		29.72% Impervious Area

Tc (min)	Length (feet)	Slope (ft/ft)	Velocity (ft/sec)	Capacity (cfs)	Description
0.2	10	0.0150	0.89		Sheet Flow, Sheet Flow Smooth surfaces n= 0.011 P2= 4.19"
9.1	93	0.0150	0.17		Sheet Flow, Sheet Flow Grass: Short n= 0.150 P2= 4.19"
0.4	40	0.0110	1.57		Shallow Concentrated Flow, Concentrated Flow Grassed Waterway Kv= 15.0 fps
0.3	33	0.0190	2.07		Shallow Concentrated Flow, Concentrated Flow Grassed Waterway Kv= 15.0 fps
0.0	6	0.0180	2.72		Shallow Concentrated Flow, Concentrated Flow Paved Kv= 20.3 fps
10.0	182	Total			

Subcatchment B7: Drainage Basin B7

Hydrograph

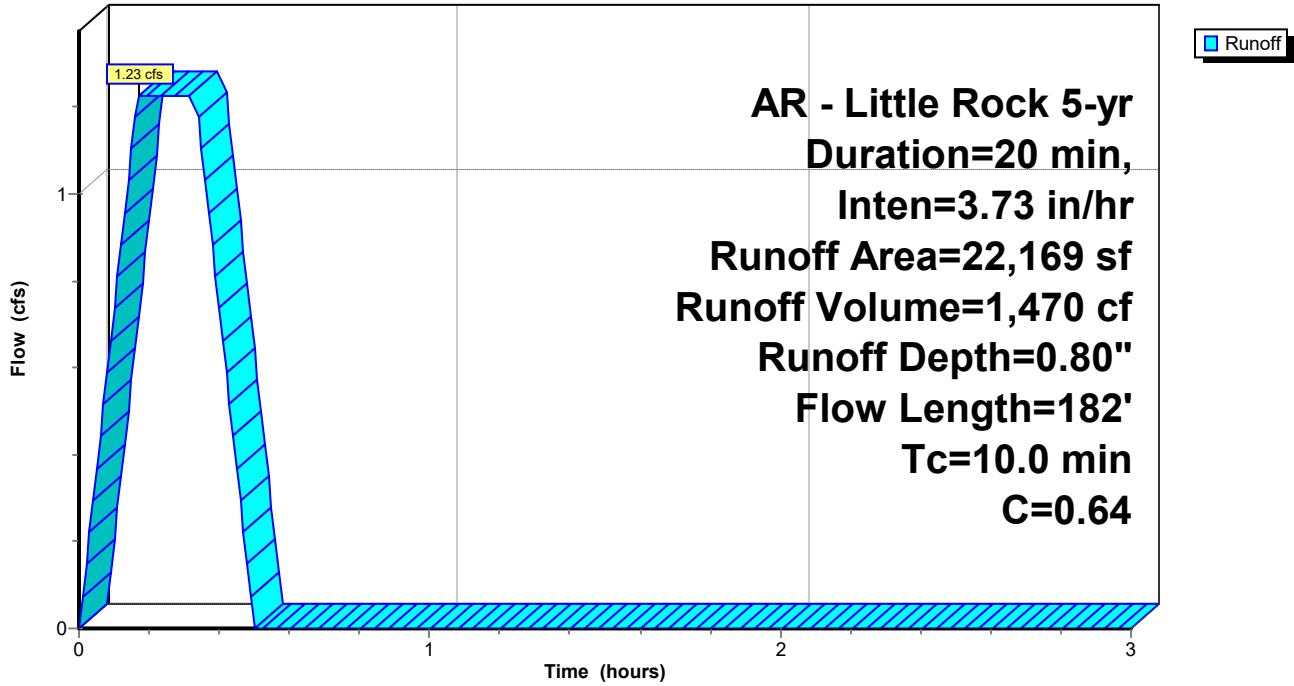

Goddard

Prepared by Phillip Lewis Engineering

HydroCAD® 10.20-5c s/n 12520 © 2023 HydroCAD Software Solutions LLC

AR - Little Rock 5-yr Duration=20 min, Inten=3.73 in/hr

Printed 3/25/2026

Summary for Subcatchment B8: Drainage Basin B8

Runoff = 0.89 cfs @ 0.24 hrs, Volume= 1,063 cf, Depth= 0.88"
 Routed to Pond CI-A4 : CI - A4

Runoff by Rational method, Rise/Fall=1.0/1.0 xTc, Time Span= 0.00-3.00 hrs, dt= 0.01 hrs
 AR - Little Rock 5-yr Duration=20 min, Inten=3.73 in/hr

Area (sf)	C	Description
7,982	0.51	Sod Yard
6,458	0.95	Paving, Sidewalks
14,440	0.71	Weighted Average
7,982		55.28% Pervious Area
6,458		44.72% Impervious Area

Tc (min)	Length (feet)	Slope (ft/ft)	Velocity (ft/sec)	Capacity (cfs)	Description
10.4	79	0.0570	0.13		Sheet Flow, Sheet Flow Grass: Bermuda n= 0.410 P2= 4.19"
3.5	21	0.0620	0.10		Sheet Flow, Sheet Flow Grass: Bermuda n= 0.410 P2= 4.19"
0.0	9	0.0620	3.73		Shallow Concentrated Flow, Concentrated Flow Grassed Waterway Kv= 15.0 fps
0.1	18	0.1080	4.93		Shallow Concentrated Flow, Concentrated Flow Grassed Waterway Kv= 15.0 fps
14.0	127	Total			

Subcatchment B8: Drainage Basin B8

Hydrograph

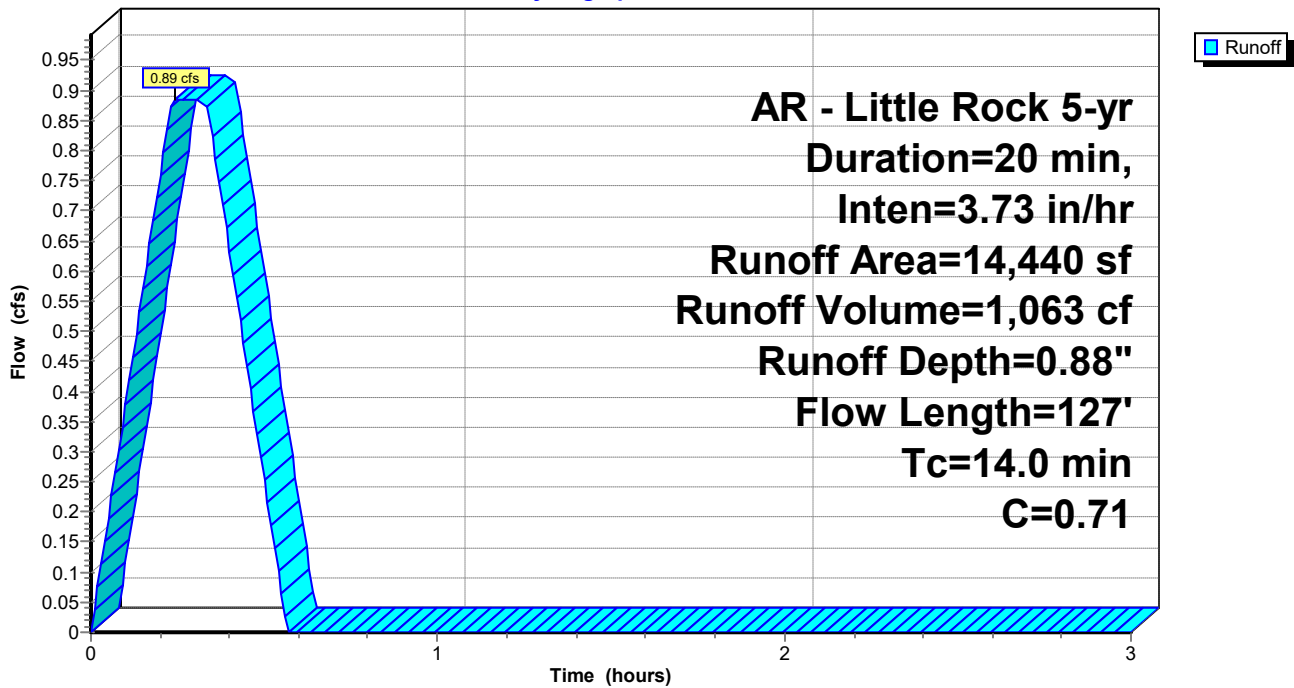

Goddard

Prepared by Phillip Lewis Engineering

HydroCAD® 10.20-5c s/n 12520 © 2023 HydroCAD Software Solutions LLC

AR - Little Rock 5-yr Duration=20 min, Inten=3.73 in/hr

Printed 3/25/2026

Summary for Subcatchment C1: Drainage Basin C1

Runoff = 1.37 cfs @ 0.09 hrs, Volume= 1,643 cf, Depth= 0.97"
 Routed to Pond CI-C1 : CI - C1

Runoff by Rational method, Rise/Fall=1.0/1.0 xTc, Time Span= 0.00-3.00 hrs, dt= 0.01 hrs
 AR - Little Rock 5-yr Duration=20 min, Inten=3.73 in/hr

Area (sf)	C	Description
6,135	0.40	Sod Yard
14,202	0.95	Paving, Sidewalks
20,337	0.78	Weighted Average
6,135		30.17% Pervious Area
14,202		69.83% Impervious Area

Tc (min)	Length (feet)	Slope (ft/ft)	Velocity (ft/sec)	Capacity (cfs)	Description
4.8	32	0.0660	0.11		Sheet Flow, Sheet Flow Grass: Bermuda n= 0.410 P2= 4.19"
0.4	102	0.0470	4.40		Shallow Concentrated Flow, Concentrated Flow Paved Kv= 20.3 fps
5.2	134	Total			

Subcatchment C1: Drainage Basin C1

Hydrograph

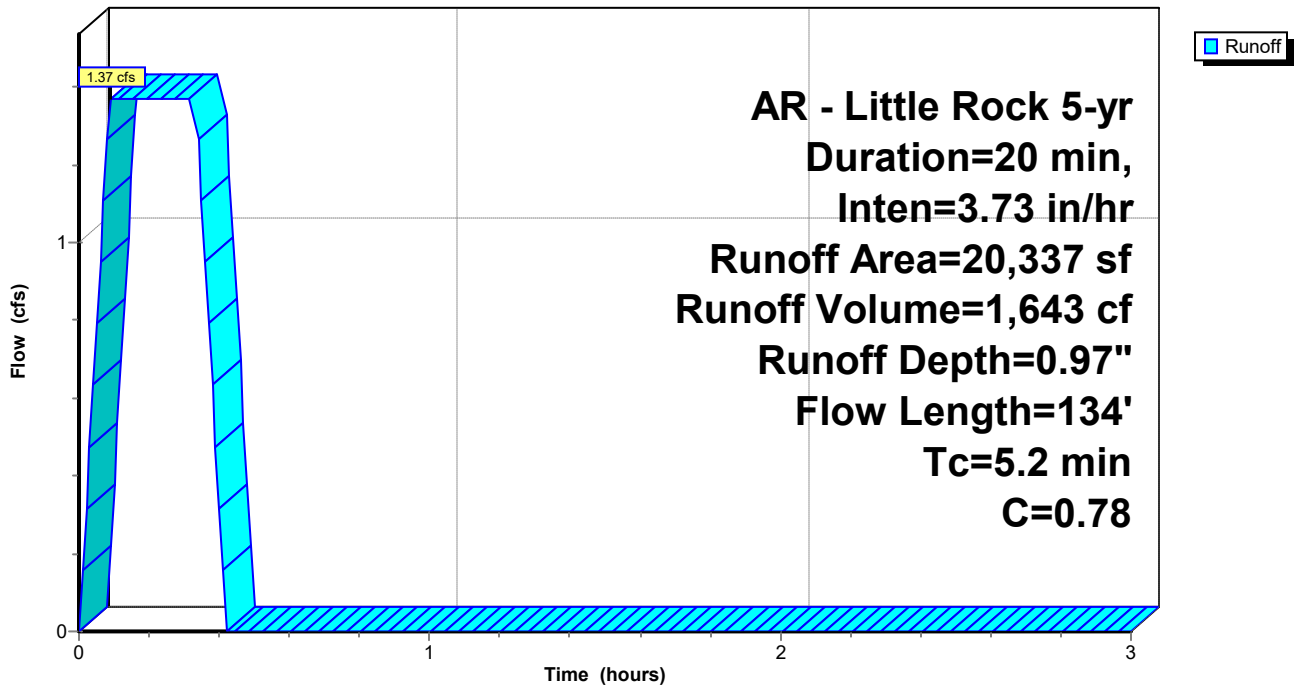

Goddard

Prepared by Phillip Lewis Engineering

HydroCAD® 10.20-5c s/n 12520 © 2023 HydroCAD Software Solutions LLC

AR - Little Rock 5-yr Duration=20 min, Inten=3.73 in/hr

Printed 3/25/2026

Summary for Subcatchment C10: Drainage Basin C10

Runoff = 0.39 cfs @ 0.09 hrs, Volume= 465 cf, Depth= 1.03"
 Routed to Pond CI-E1 : CI - E1

Runoff by Rational method, Rise/Fall=1.0/1.0 xTc, Time Span= 0.00-3.00 hrs, dt= 0.01 hrs
 AR - Little Rock 5-yr Duration=20 min, Inten=3.73 in/hr

Area (sf)	C	Description
1,225	0.40	Sod Yard
4,183	0.95	Paving, Sidewalks
5,408	0.83	Weighted Average
1,225		22.65% Pervious Area
4,183		77.35% Impervious Area

Tc (min)	Length (feet)	Slope (ft/ft)	Velocity (ft/sec)	Capacity (cfs)	Description
0.3	18	0.0200	1.12		Sheet Flow, Sheet Flow Smooth surfaces n= 0.011 P2= 4.19"
0.2	29	0.0210	2.94		Shallow Concentrated Flow, Concentrated Flow Paved Kv= 20.3 fps
0.1	23	0.0320	3.63		Shallow Concentrated Flow, Concentrated Flow Paved Kv= 20.3 fps
0.2	36	0.0320	3.63		Shallow Concentrated Flow, Concentrated Flow Paved Kv= 20.3 fps
0.2	48	0.0330	3.69		Shallow Concentrated Flow, Concentrated Flow Paved Kv= 20.3 fps
0.1	13	0.0350	3.80		Shallow Concentrated Flow, Concentrated Flow Paved Kv= 20.3 fps
3.9	415		1.77		Direct Entry, Concentrated Flow (Min)
5.0	582	Total			

Subcatchment C10: Drainage Basin C10

Hydrograph

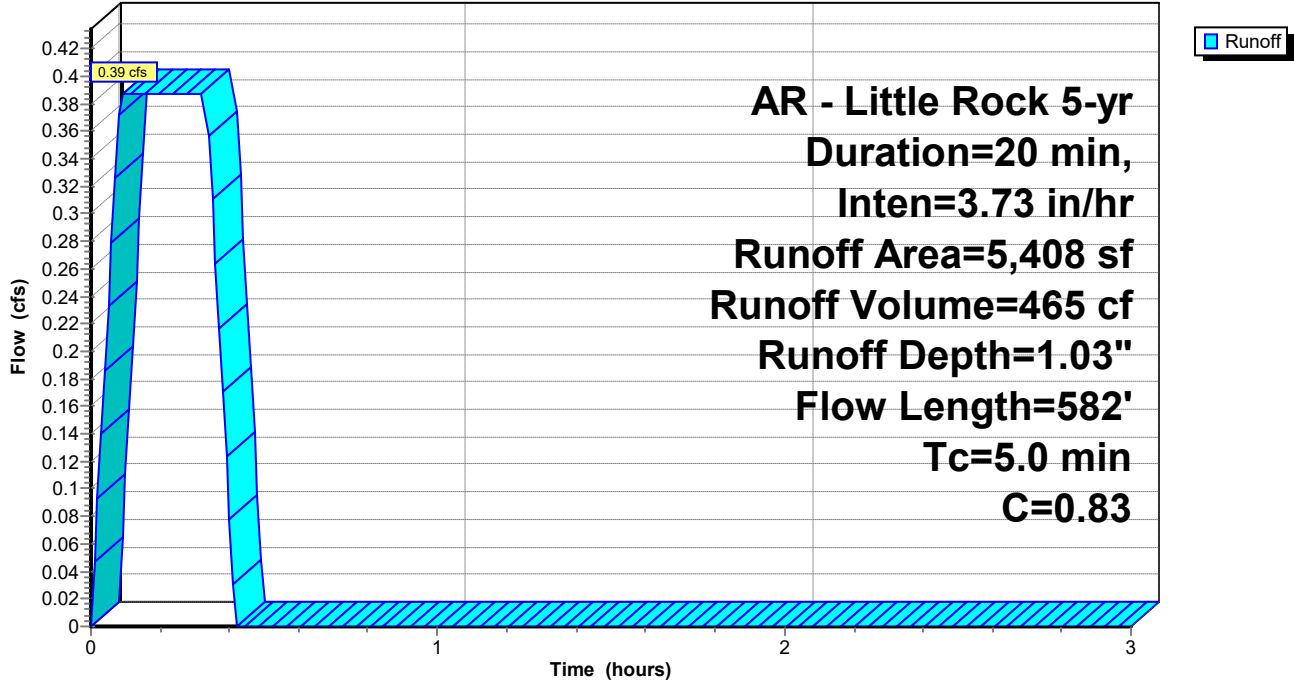

Goddard

Prepared by Phillip Lewis Engineering

HydroCAD® 10.20-5c s/n 12520 © 2023 HydroCAD Software Solutions LLC

AR - Little Rock 5-yr Duration=20 min, Inten=3.73 in/hr

Printed 3/25/2026

Summary for Subcatchment C11: Drainage Basin C11

Runoff = 0.37 cfs @ 0.09 hrs, Volume= 442 cf, Depth= 0.86"
 Routed to Pond CI-E2 : CI - E2

Runoff by Rational method, Rise/Fall=1.0/1.0 xTc, Time Span= 0.00-3.00 hrs, dt= 0.01 hrs
 AR - Little Rock 5-yr Duration=20 min, Inten=3.73 in/hr

Area (sf)	C	Description
2,876	0.40	Sod Yard
3,307	0.95	Paving, Sidewalks
6,183	0.69	Weighted Average
2,876		46.51% Pervious Area
3,307		53.49% Impervious Area

Tc (min)	Length (feet)	Slope (ft/ft)	Velocity (ft/sec)	Capacity (cfs)	Description
0.3	25	0.0200	1.19		Sheet Flow, Sheet Flow Smooth surfaces n= 0.011 P2= 4.19"
0.1	33	0.0620	5.05		Shallow Concentrated Flow, Concentrated Flow Paved Kv= 20.3 fps
0.1	29	0.0540	4.72		Shallow Concentrated Flow, Concentrated Flow Paved Kv= 20.3 fps
0.2	47	0.0410	4.11		Shallow Concentrated Flow, Concentrated Flow Paved Kv= 20.3 fps
0.2	47	0.0390	4.01		Shallow Concentrated Flow, Concentrated Flow Paved Kv= 20.3 fps
0.1	37	0.0420	4.16		Shallow Concentrated Flow, Concentrated Flow Paved Kv= 20.3 fps
4.0	415		1.73		Direct Entry, Concentrated Flow (Min)
5.0	633	Total			

Subcatchment C11: Drainage Basin C11

Hydrograph

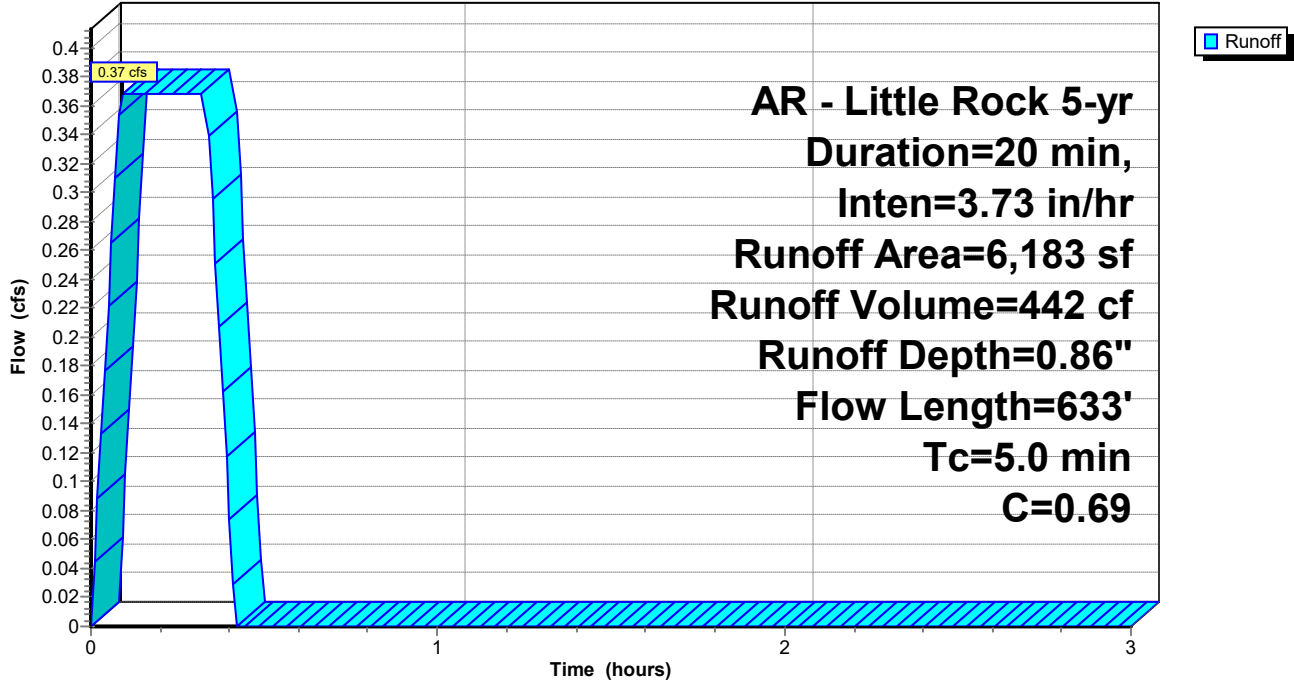

Goddard

Prepared by Phillip Lewis Engineering

HydroCAD® 10.20-5c s/n 12520 © 2023 HydroCAD Software Solutions LLC

AR - Little Rock 5-yr Duration=20 min, Inten=3.73 in/hr

Printed 3/25/2026

Summary for Subcatchment C12: Drainage Basin C12

Runoff = 1.77 cfs @ 0.09 hrs, Volume= 2,127 cf, Depth= 0.99"
 Routed to Pond CI-C7 : CI - C7

Runoff by Rational method, Rise/Fall=1.0/1.0 xTc, Time Span= 0.00-3.00 hrs, dt= 0.01 hrs
 AR - Little Rock 5-yr Duration=20 min, Inten=3.73 in/hr

Area (sf)	C	Description
7,218	0.40	Sod Yard
18,440	0.95	Paving, Sidewalks
25,658	0.80	Weighted Average
7,218		28.13% Pervious Area
18,440		71.87% Impervious Area

Tc (min)	Length (feet)	Slope (ft/ft)	Velocity (ft/sec)	Capacity (cfs)	Description
0.3	24	0.0360	1.50		Sheet Flow, Sheet Flow Smooth surfaces n= 0.011 P2= 4.19"
0.1	5	0.0190	0.85		Sheet Flow, Sheet Flow Smooth surfaces n= 0.011 P2= 4.19"
0.2	21	0.0100	2.03		Shallow Concentrated Flow, Concentrated Flow Paved Kv= 20.3 fps
0.9	49	0.0020	0.91		Shallow Concentrated Flow, Concentrated Flow Paved Kv= 20.3 fps
0.4	96	0.0330	3.69		Shallow Concentrated Flow, Concentrated Flow Paved Kv= 20.3 fps
0.3	94	0.0570	4.85		Shallow Concentrated Flow, Concentrated Flow Paved Kv= 20.3 fps
0.1	28	0.0560	4.80		Shallow Concentrated Flow, Concentrated Flow Paved Kv= 20.3 fps
0.1	25	0.0450	4.31		Shallow Concentrated Flow, Concentrated Flow Paved Kv= 20.3 fps
0.1	31	0.0410	4.11		Shallow Concentrated Flow, Concentrated Flow Paved Kv= 20.3 fps
0.1	39	0.0490	4.49		Shallow Concentrated Flow, Concentrated Flow Paved Kv= 20.3 fps
0.1	36	0.0460	4.35		Shallow Concentrated Flow, Concentrated Flow Paved Kv= 20.3 fps
0.0	11	0.0470	4.40		Shallow Concentrated Flow, Concentrated Flow Paved Kv= 20.3 fps
0.0	6	0.0440	4.26		Shallow Concentrated Flow, Concentrated Flow Paved Kv= 20.3 fps
2.3	415		3.01		Direct Entry, Concentrated Flow (Min)
5.0	880	Total			

Subcatchment C12: Drainage Basin C12

Hydrograph

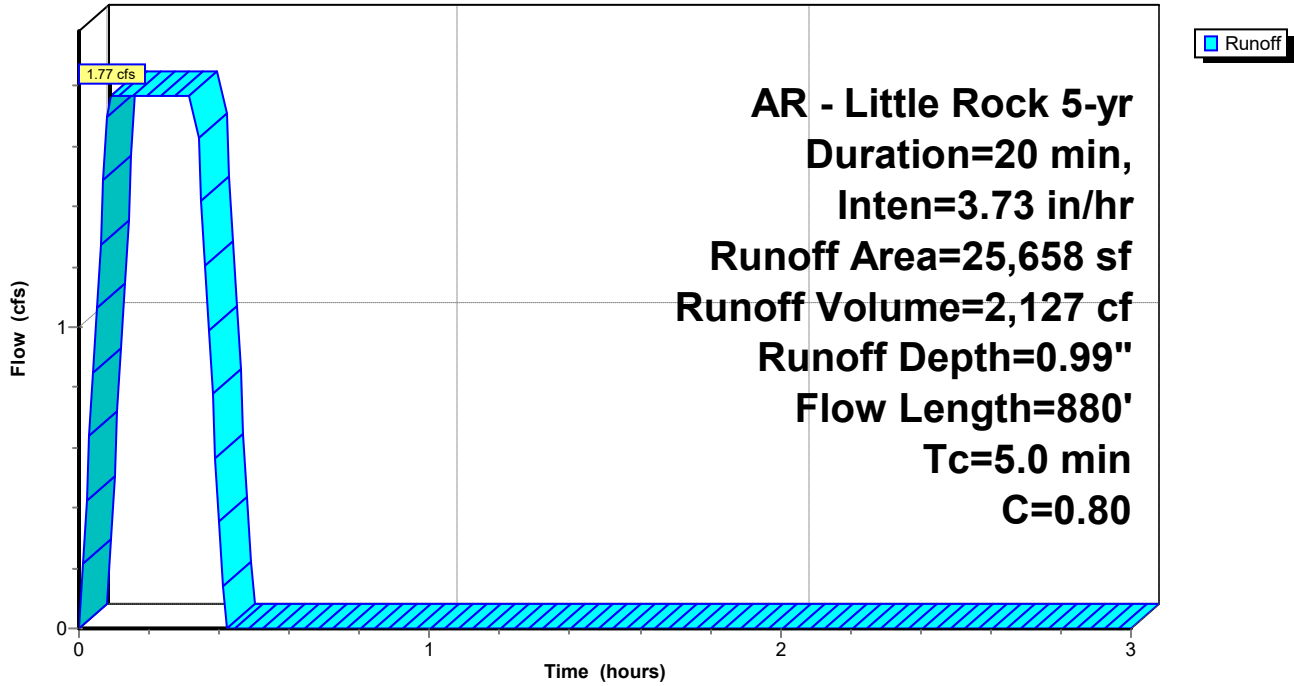

Goddard

Prepared by Phillip Lewis Engineering

HydroCAD® 10.20-5c s/n 12520 © 2023 HydroCAD Software Solutions LLC

AR - Little Rock 5-yr Duration=20 min, Inten=3.73 in/hr

Printed 3/25/2026

Summary for Subcatchment C13: Drainage Basin C13

Runoff = 0.58 cfs @ 0.09 hrs, Volume= 692 cf, Depth= 1.04"
 Routed to Pond CI-A4 : CI - A4

Runoff by Rational method, Rise/Fall=1.0/1.0 xTc, Time Span= 0.00-3.00 hrs, dt= 0.01 hrs
 AR - Little Rock 5-yr Duration=20 min, Inten=3.73 in/hr

Area (sf)	C	Description
1,558	0.40	Sod Yard
6,388	0.95	Paving, Sidewalks
7,946	0.84	Weighted Average
1,558		19.61% Pervious Area
6,388		80.39% Impervious Area

Tc (min)	Length (feet)	Slope (ft/ft)	Velocity (ft/sec)	Capacity (cfs)	Description
0.3	19	0.0200	1.13		Sheet Flow, Sheet Flow Smooth surfaces n= 0.011 P2= 4.19"
0.3	75	0.0340	3.74		Shallow Concentrated Flow, Concentrated Flow Paved Kv= 20.3 fps
0.2	52	0.0410	4.11		Shallow Concentrated Flow, Concentrated Flow Paved Kv= 20.3 fps
0.1	29	0.0470	4.40		Shallow Concentrated Flow, Concentrated Flow Paved Kv= 20.3 fps
0.1	42	0.0730	5.48		Shallow Concentrated Flow, Concentrated Flow Paved Kv= 20.3 fps
0.2	74	0.0750	5.56		Shallow Concentrated Flow, Concentrated Flow Paved Kv= 20.3 fps
0.1	26	0.0710	5.41		Shallow Concentrated Flow, Concentrated Flow Paved Kv= 20.3 fps
0.1	32	0.0570	4.85		Shallow Concentrated Flow, Concentrated Flow Paved Kv= 20.3 fps
0.0	13	0.0470	4.40		Shallow Concentrated Flow, Concentrated Flow Paved Kv= 20.3 fps
3.6	415		1.92		Direct Entry, Overland Concentrated Flow (Min)
5.0	777	Total			

Subcatchment C13: Drainage Basin C13

Hydrograph

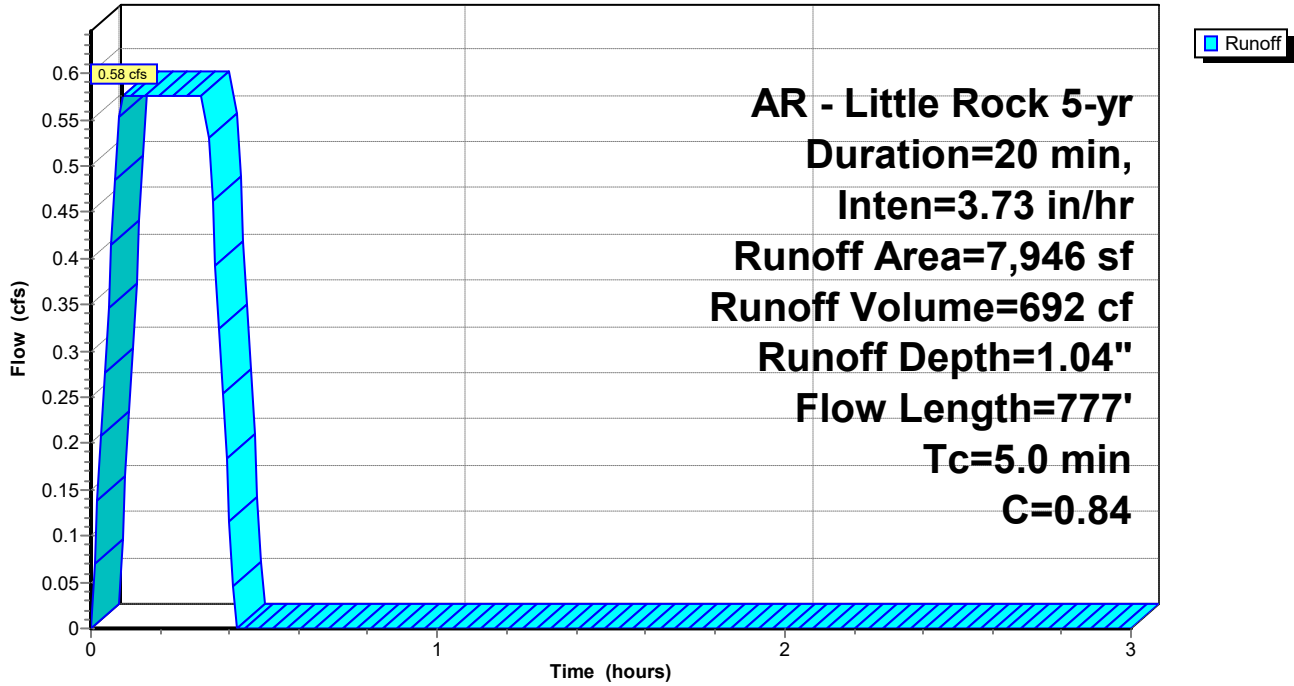

Goddard

Prepared by Phillip Lewis Engineering

HydroCAD® 10.20-5c s/n 12520 © 2023 HydroCAD Software Solutions LLC

AR - Little Rock 5-yr Duration=20 min, Inten=3.73 in/hr

Printed 3/25/2026

Summary for Subcatchment C14: Drainage Basin C14

Runoff = 1.52 cfs @ 0.27 hrs, Volume= 1,826 cf, Depth= 1.00"
 Routed to Pond CI-A5 : CI - A5

Runoff by Rational method, Rise/Fall=1.0/1.0 xTc, Time Span= 0.00-3.00 hrs, dt= 0.01 hrs
 AR - Little Rock 5-yr Duration=20 min, Inten=3.73 in/hr

Area (sf)	C	Description
6,127	0.40	Sod Yard
15,898	0.95	Paving, Sidewalks
22,025	0.80	Weighted Average
6,127		27.82% Pervious Area
15,898		72.18% Impervious Area

Tc (min)	Length (feet)	Slope (ft/ft)	Velocity (ft/sec)	Capacity (cfs)	Description
1.5	5	0.0310	0.06		Sheet Flow, Sheet Flow
					Grass: Bermuda n= 0.410 P2= 4.19"
9.2	45	0.0250	0.08		Sheet Flow, Sheet Flow
					Grass: Bermuda n= 0.410 P2= 4.19"
3.8	41	0.1940	0.18		Sheet Flow, Sheet Flow
					Grass: Bermuda n= 0.410 P2= 4.19"
0.1	6	0.0100	0.68		Sheet Flow, Sheet Flow
					Smooth surfaces n= 0.011 P2= 4.19"
0.1	51	0.0870	5.99		Shallow Concentrated Flow, Concentrated Flow
					Paved Kv= 20.3 fps
0.2	52	0.0310	3.57		Shallow Concentrated Flow, Concentrated Flow
					Paved Kv= 20.3 fps
0.1	18	0.0270	3.34		Shallow Concentrated Flow, Concentrated Flow
					Paved Kv= 20.3 fps
0.1	20	0.0400	4.06		Shallow Concentrated Flow, Concentrated Flow
					Paved Kv= 20.3 fps
0.1	34	0.0410	4.11		Shallow Concentrated Flow, Concentrated Flow
					Paved Kv= 20.3 fps
0.2	46	0.0470	4.40		Shallow Concentrated Flow, Concentrated Flow
					Paved Kv= 20.3 fps
0.1	36	0.0580	4.89		Shallow Concentrated Flow, Concentrated Flow
					Paved Kv= 20.3 fps
0.2	58	0.0690	5.33		Shallow Concentrated Flow, Concentrated Flow
					Paved Kv= 20.3 fps
0.1	49	0.0840	5.88		Shallow Concentrated Flow, Concentrated Flow
					Paved Kv= 20.3 fps
0.1	31	0.0690	5.33		Shallow Concentrated Flow, Concentrated Flow
					Paved Kv= 20.3 fps
15.9	492	Total			

Subcatchment C14: Drainage Basin C14

Hydrograph

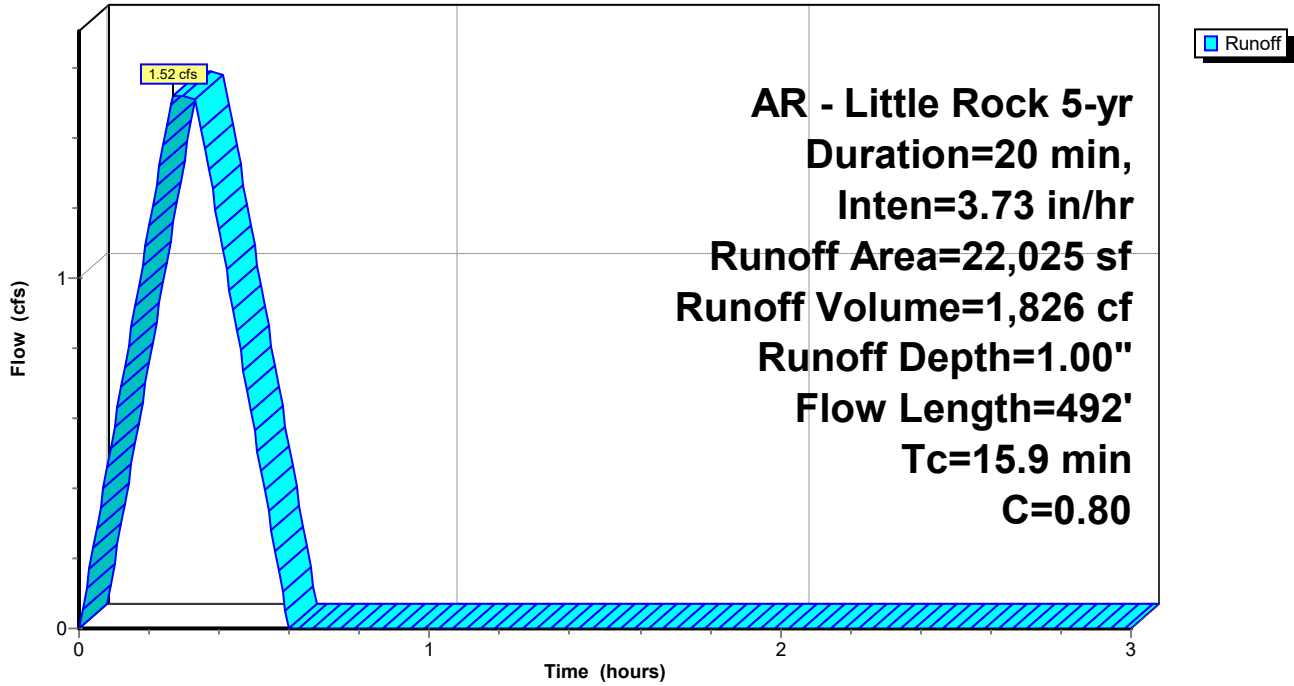

Summary for Subcatchment C15: Drainage Basin C15

Runoff = 1.10 cfs @ 0.09 hrs, Volume= 1,324 cf, Depth= 1.18"

Routed to Pond DP : Existing North Detention Pond

Runoff by Rational method, Rise/Fall=1.0/1.0 xTc, Time Span= 0.00-3.00 hrs, dt= 0.01 hrs

AR - Little Rock 5-yr Duration=20 min, Inten=3.73 in/hr

Area (sf)	C	Description
0	0.40	Sod Yard
13,450	0.95	Paving, Sidewalks
13,450	0.95	Weighted Average
13,450		100.00% Impervious Area

Tc (min)	Length (feet)	Slope (ft/ft)	Velocity (ft/sec)	Capacity (cfs)	Description
5.0	415		1.38		Direct Entry, Overland Concentrated Flow (Min)

Subcatchment C15: Drainage Basin C15

Hydrograph

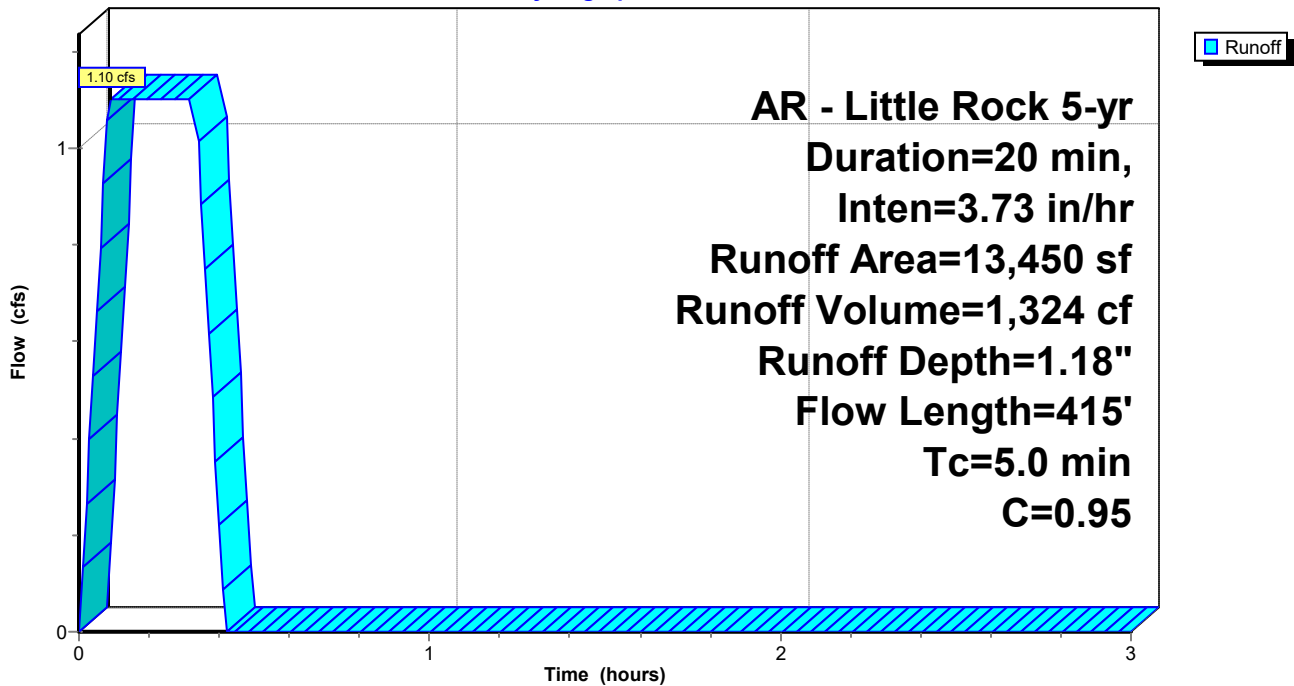

Goddard

Prepared by Phillip Lewis Engineering

HydroCAD® 10.20-5c s/n 12520 © 2023 HydroCAD Software Solutions LLC

AR - Little Rock 5-yr Duration=20 min, Inten=3.73 in/hr

Printed 3/25/2026

Summary for Subcatchment C16: Drainage Basin C16

Runoff = 1.07 cfs @ 0.09 hrs, Volume= 1,281 cf, Depth= 0.70"

Routed to Pond DP : Existing North Detention Pond

Runoff by Rational method, Rise/Fall=1.0/1.0 xTc, Time Span= 0.00-3.00 hrs, dt= 0.01 hrs

AR - Little Rock 5-yr Duration=20 min, Inten=3.73 in/hr

Area (sf)	C	Description
15,465	0.40	Sod Yard
6,612	0.95	Paving, Sidewalks
22,077	0.56	Weighted Average
15,465		70.05% Pervious Area
6,612		29.95% Impervious Area

Tc (min)	Length (feet)	Slope (ft/ft)	Velocity (ft/sec)	Capacity (cfs)	Description
0.4	26	0.0190	1.18		Sheet Flow, Sheet Flow Smooth surfaces n= 0.011 P2= 4.19"
0.1	5	0.0100	0.66		Sheet Flow, Sheet Flow Smooth surfaces n= 0.011 P2= 4.19"
0.4	51	0.0500	1.98		Sheet Flow, Sheet Flow Smooth surfaces n= 0.011 P2= 4.19"
0.1	12	0.1540	2.33		Sheet Flow, Sheet Flow Smooth surfaces n= 0.011 P2= 4.19"
0.1	50	0.1330	7.40		Shallow Concentrated Flow, Concentrated Flow Paved Kv= 20.3 fps
0.1	50	0.1170	6.94		Shallow Concentrated Flow, Concentrated Flow Paved Kv= 20.3 fps
0.2	46	0.0430	4.21		Shallow Concentrated Flow, Concentrated Flow Paved Kv= 20.3 fps
0.3	59	0.0370	3.90		Shallow Concentrated Flow, Concentrated Flow Paved Kv= 20.3 fps
3.3	415		2.10		Direct Entry, Overland Concentrated Flow (Min)
5.0	714	Total			

Subcatchment C16: Drainage Basin C16

Hydrograph

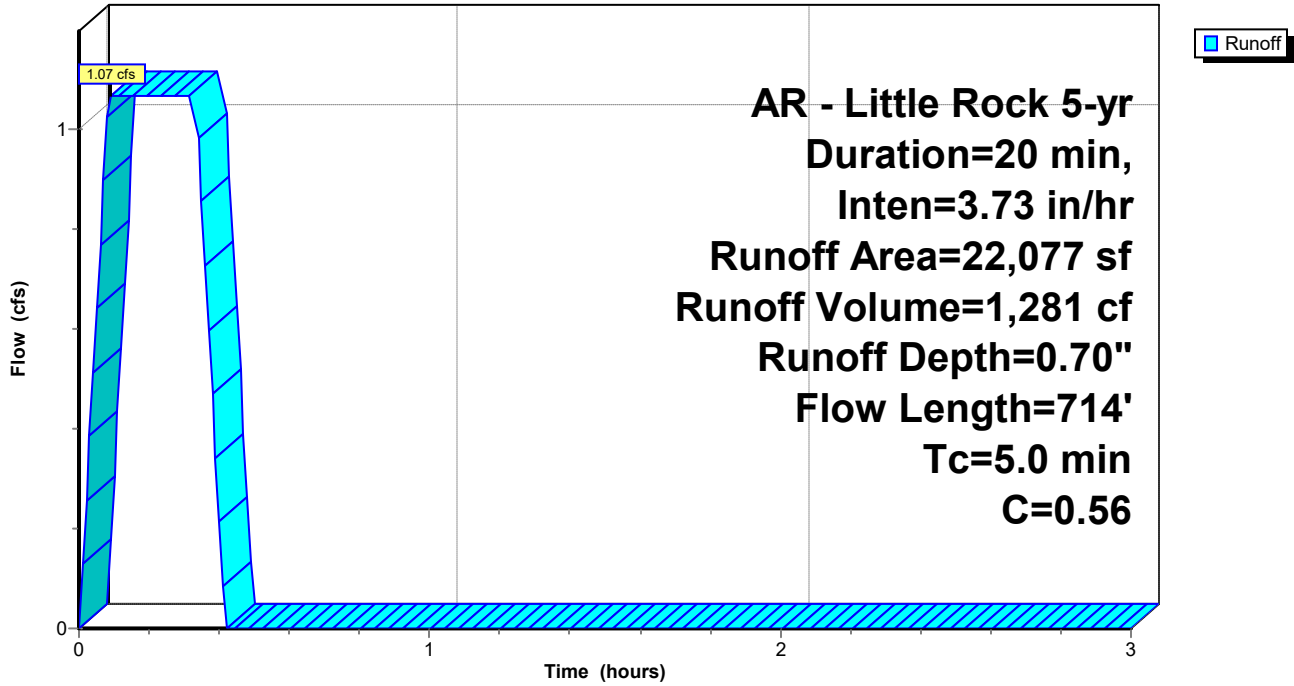

Goddard

Prepared by Phillip Lewis Engineering

HydroCAD® 10.20-5c s/n 12520 © 2023 HydroCAD Software Solutions LLC

AR - Little Rock 5-yr Duration=20 min, Inten=3.73 in/hr

Printed 3/25/2026

Summary for Subcatchment C17: Drainage Basin C17

Runoff = 1.96 cfs @ 0.16 hrs, Volume= 2,353 cf, Depth= 0.50"

Routed to Pond DP : Existing North Detention Pond

Runoff by Rational method, Rise/Fall=1.0/1.0 xTc, Time Span= 0.00-3.00 hrs, dt= 0.01 hrs

AR - Little Rock 5-yr Duration=20 min, Inten=3.73 in/hr

Area (sf)	C	Description
56,749	0.40	Sod Yard
0	0.95	Paving, Sidewalks
56,749	0.40	Weighted Average
56,749		100.00% Pervious Area

Tc (min)	Length (feet)	Slope (ft/ft)	Velocity (ft/sec)	Capacity (cfs)	Description
4.8	43	0.0410	0.15		Sheet Flow, Sheet Flow
					Grass: Dense n= 0.240 P2= 4.19"
3.9	43	0.0690	0.19		Sheet Flow, Sheet Flow
					Grass: Dense n= 0.240 P2= 4.19"
0.1	41	0.0980	4.70		Shallow Concentrated Flow, Concentrated Flow
					Grassed Waterway Kv= 15.0 fps
0.3	61	0.0730	4.05		Shallow Concentrated Flow, Concentrated Flow
					Grassed Waterway Kv= 15.0 fps
0.2	46	0.0570	3.58		Shallow Concentrated Flow, Concentrated Flow
					Grassed Waterway Kv= 15.0 fps
0.3	64	0.0450	3.18		Shallow Concentrated Flow, Concentrated Flow
					Grassed Waterway Kv= 15.0 fps
9.6	298	Total			

Subcatchment C17: Drainage Basin C17

Hydrograph

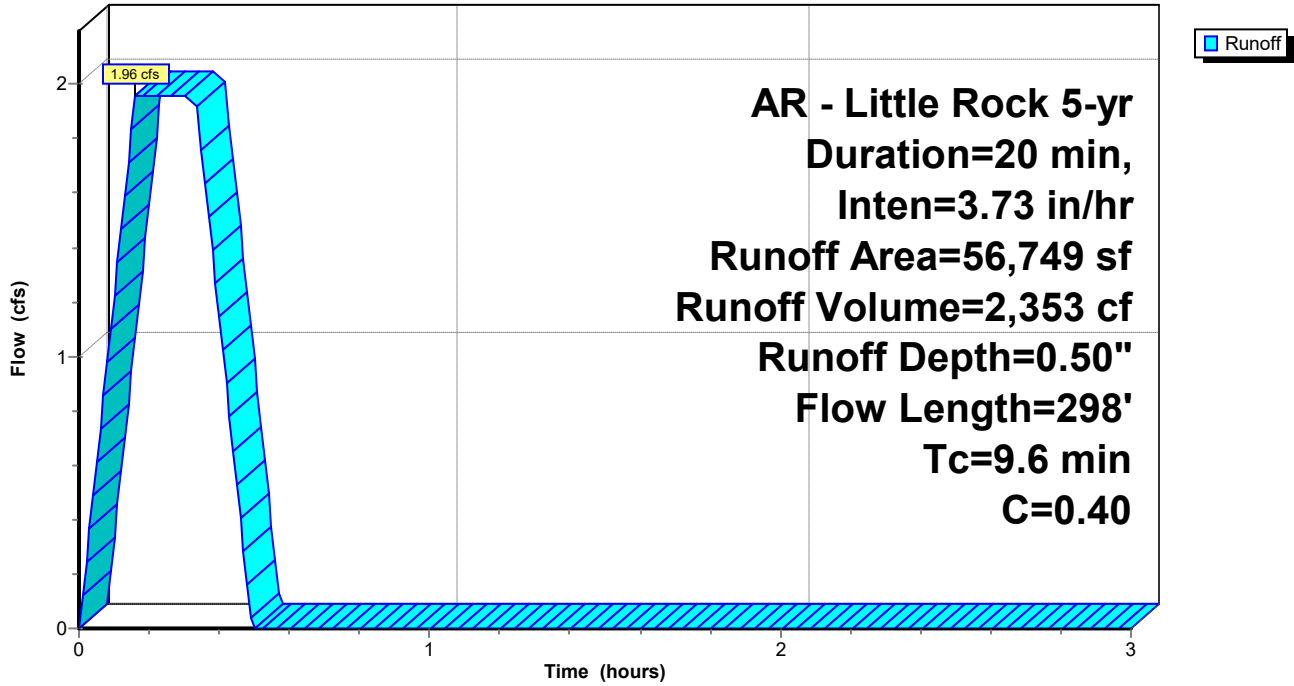

Goddard

Prepared by Phillip Lewis Engineering

HydroCAD® 10.20-5c s/n 12520 © 2023 HydroCAD Software Solutions LLC

AR - Little Rock 5-yr Duration=20 min, Inten=3.73 in/hr

Printed 3/25/2026

Summary for Subcatchment C18: Drainage Basin C18

Runoff = 1.26 cfs @ 0.09 hrs, Volume= 1,511 cf, Depth= 0.80"

Routed to Link FINAL : APPROX DISCHARGE

Runoff by Rational method, Rise/Fall=1.0/1.0 xTc, Time Span= 0.00-3.00 hrs, dt= 0.01 hrs

AR - Little Rock 5-yr Duration=20 min, Inten=3.73 in/hr

Area (sf)	C	Description
12,812	0.40	Sod Yard
9,973	0.95	Paving, Sidewalks
22,785	0.64	Weighted Average
12,812		56.23% Pervious Area
9,973		43.77% Impervious Area

Tc (min)	Length (feet)	Slope (ft/ft)	Velocity (ft/sec)	Capacity (cfs)	Description
0.6	5	0.2980	0.14		Sheet Flow, Sheet Flow Grass: Bermuda n= 0.410 P2= 4.19"
0.2	12	0.0130	0.87		Sheet Flow, Sheet Flow Smooth surfaces n= 0.011 P2= 4.19"
3.3	8	0.0100	0.04		Sheet Flow, Sheet Flow Grass: Bermuda n= 0.410 P2= 4.19"
0.5	80	0.0210	2.94		Shallow Concentrated Flow, Concentrated Flow Paved Kv= 20.3 fps
0.4	415		17.29		Direct Entry, Concentrated Flow (Min)
5.0	520	Total			

Subcatchment C18: Drainage Basin C18

Hydrograph

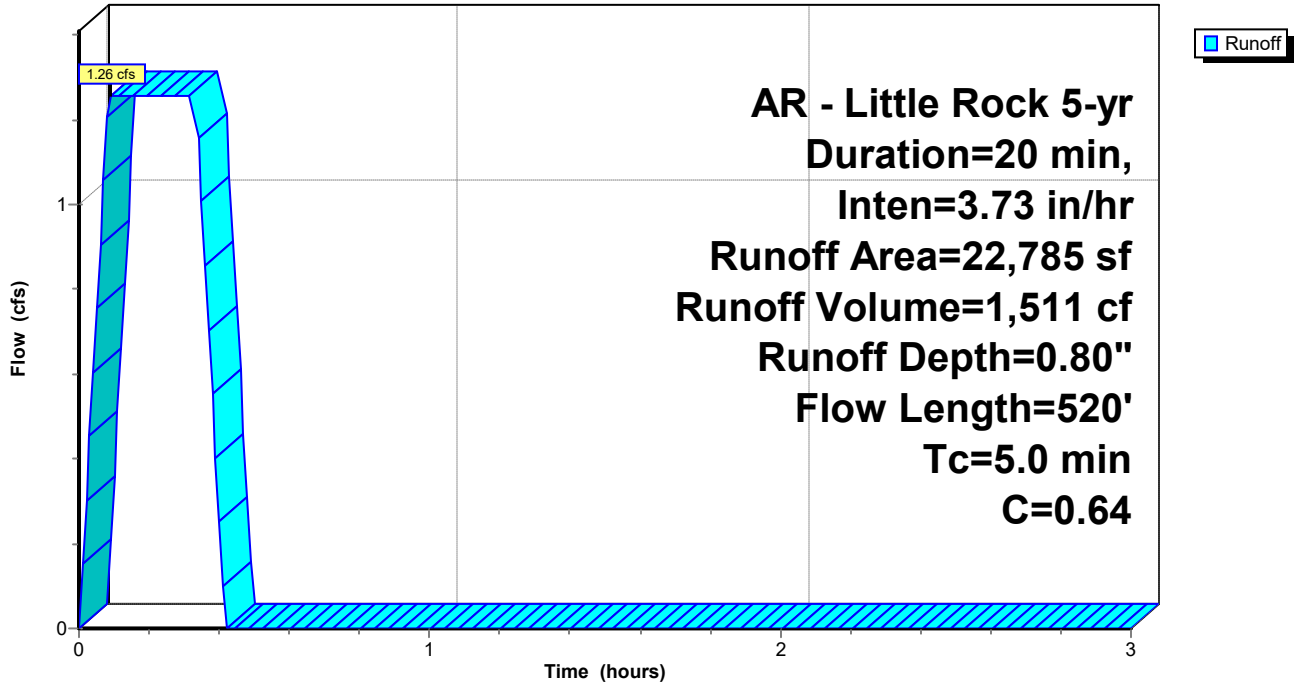

Goddard

Prepared by Phillip Lewis Engineering

HydroCAD® 10.20-5c s/n 12520 © 2023 HydroCAD Software Solutions LLC

AR - Little Rock 5-yr Duration=20 min, Inten=3.73 in/hr

Printed 3/25/2026

Summary for Subcatchment C19: Drainage Basin C19

Runoff = 0.62 cfs @ 0.12 hrs, Volume= 747 cf, Depth= 0.50"
 Routed to Link FINAL : APPROX DISCHARGE

Runoff by Rational method, Rise/Fall=1.0/1.0 xTc, Time Span= 0.00-3.00 hrs, dt= 0.01 hrs
 AR - Little Rock 5-yr Duration=20 min, Inten=3.73 in/hr

Area (sf)	C	Description
18,009	0.40	Sod Yard
0	0.95	Paving, Sidewalks
18,009	0.40	Weighted Average
18,009		100.00% Pervious Area

Tc (min)	Length (feet)	Slope (ft/ft)	Velocity (ft/sec)	Capacity (cfs)	Description
2.7	34	0.1110	0.21		Sheet Flow, Sheet Flow Grass: Dense n= 0.240 P2= 4.19"
3.3	66	0.2450	0.34		Sheet Flow, Sheet Flow Grass: Dense n= 0.240 P2= 4.19"
0.0	9	0.2450	7.42		Shallow Concentrated Flow, Concentrated Flow Grassed Waterway Kv= 15.0 fps
0.5	106	0.0610	3.70		Shallow Concentrated Flow, Concentrated Flow Grassed Waterway Kv= 15.0 fps
0.2	46	0.0800	4.24		Shallow Concentrated Flow, Concentrated Flow Grassed Waterway Kv= 15.0 fps
0.1	41	0.0960	4.65		Shallow Concentrated Flow, Concentrated Flow Grassed Waterway Kv= 15.0 fps
0.3	66	0.0680	3.91		Shallow Concentrated Flow, Concentrated Flow Grassed Waterway Kv= 15.0 fps
0.1	19	0.1070	4.91		Shallow Concentrated Flow, Concentrated Flow Grassed Waterway Kv= 15.0 fps
0.0	6	0.0750	4.11		Shallow Concentrated Flow, Concentrated Flow Grassed Waterway Kv= 15.0 fps
7.2	393	Total			

Subcatchment C19: Drainage Basin C19

Hydrograph

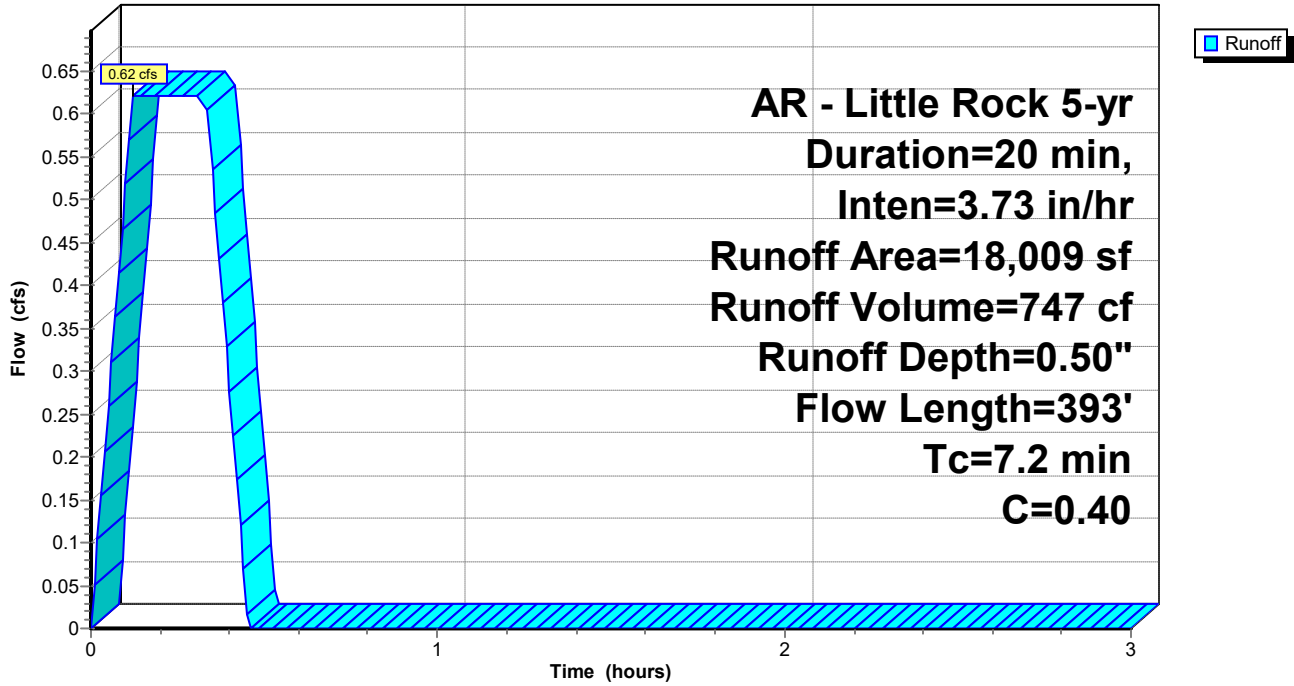

Goddard

Prepared by Phillip Lewis Engineering

HydroCAD® 10.20-5c s/n 12520 © 2023 HydroCAD Software Solutions LLC

AR - Little Rock 5-yr Duration=20 min, Inten=3.73 in/hr

Printed 3/25/2026

Summary for Subcatchment C2: Drainage Basin C2

Runoff = 2.28 cfs @ 0.09 hrs, Volume= 2,740 cf, Depth= 0.96"
 Routed to Pond CI-C2 : CI - C2

Runoff by Rational method, Rise/Fall=1.0/1.0 xTc, Time Span= 0.00-3.00 hrs, dt= 0.01 hrs
 AR - Little Rock 5-yr Duration=20 min, Inten=3.73 in/hr

Area (sf)	C	Description
11,376	0.40	Sod Yard
22,963	0.95	Roof, Paving, Sidewalks
34,339	0.77	Weighted Average
11,376		33.13% Pervious Area
22,963		66.87% Impervious Area

Tc (min)	Length (feet)	Slope (ft/ft)	Velocity (ft/sec)	Capacity (cfs)	Description
0.3	20	0.0200	1.14		Sheet Flow, Sheet Flow Smooth surfaces n= 0.011 P2= 4.19"
0.4	74	0.0240	3.14		Shallow Concentrated Flow, Concentrated Flow Paved Kv= 20.3 fps
0.1	17	0.0710	5.41		Shallow Concentrated Flow, Concentrated Flow Paved Kv= 20.3 fps
0.1	21	0.0610	5.01		Shallow Concentrated Flow, Concentrated Flow Paved Kv= 20.3 fps
0.6	148	0.0380	3.96		Shallow Concentrated Flow, Concentrated Flow Paved Kv= 20.3 fps
3.5	415		1.98		Direct Entry, Concentrated Flow (Min)
5.0	695	Total			

Subcatchment C2: Drainage Basin C2

Hydrograph

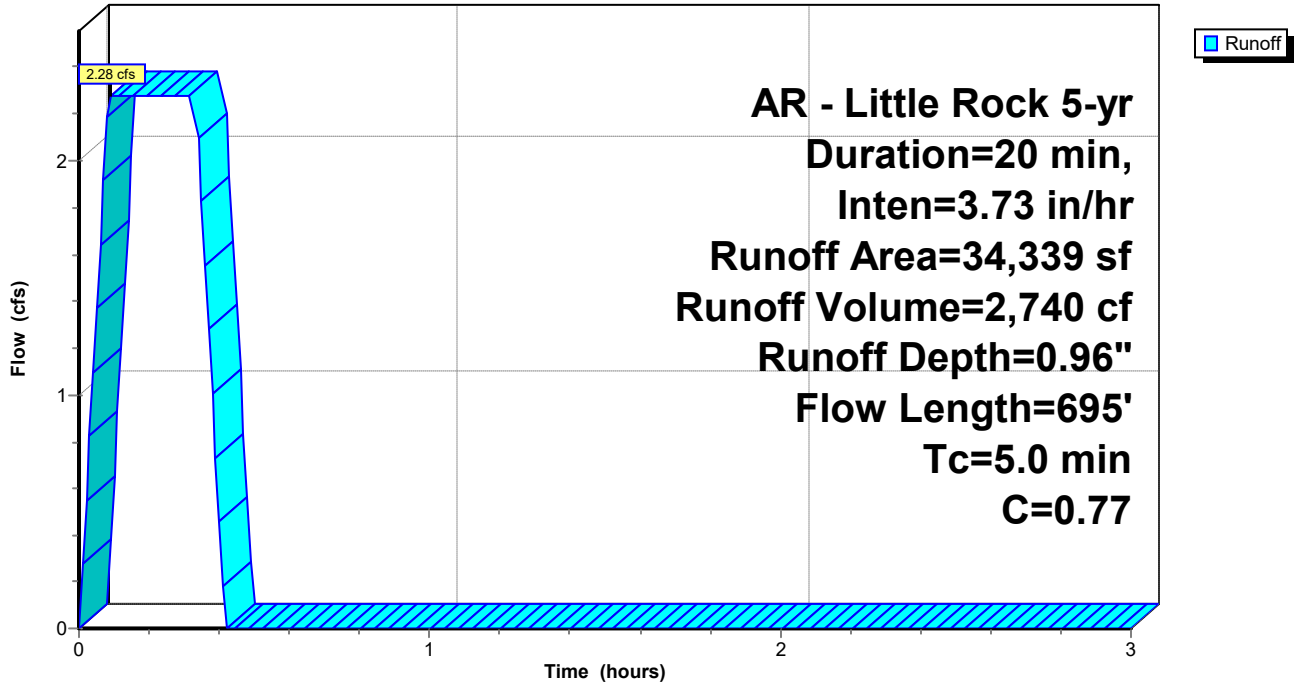

Goddard

Prepared by Phillip Lewis Engineering

HydroCAD® 10.20-5c s/n 12520 © 2023 HydroCAD Software Solutions LLC

AR - Little Rock 5-yr Duration=20 min, Inten=3.73 in/hr

Printed 3/25/2026

Summary for Subcatchment C20: Drainage Basin C20

Runoff = 1.06 cfs @ 0.14 hrs, Volume= 1,277 cf, Depth= 0.50"

Routed to Link FINAL : APPROX DISCHARGE

Runoff by Rational method, Rise/Fall=1.0/1.0 xTc, Time Span= 0.00-3.00 hrs, dt= 0.01 hrs

AR - Little Rock 5-yr Duration=20 min, Inten=3.73 in/hr

Area (sf)	C	Description
30,789	0.40	Sod Yard
0	0.95	Paving, Sidewalks
30,789	0.40	Weighted Average
30,789		100.00% Pervious Area

Tc (min)	Length (feet)	Slope (ft/ft)	Velocity (ft/sec)	Capacity (cfs)	Description
3.0	45	0.1430	0.25		Sheet Flow, Sheet Flow Grass: Dense n= 0.240 P2= 4.19"
4.5	55	0.0780	0.20		Sheet Flow, Sheet Flow Grass: Dense n= 0.240 P2= 4.19"
0.1	37	0.0780	4.19		Shallow Concentrated Flow, Concentrated Flow Grassed Waterway Kv= 15.0 fps
0.3	68	0.0710	4.00		Shallow Concentrated Flow, Concentrated Flow Grassed Waterway Kv= 15.0 fps
7.9	205	Total			

Subcatchment C20: Drainage Basin C20

Hydrograph

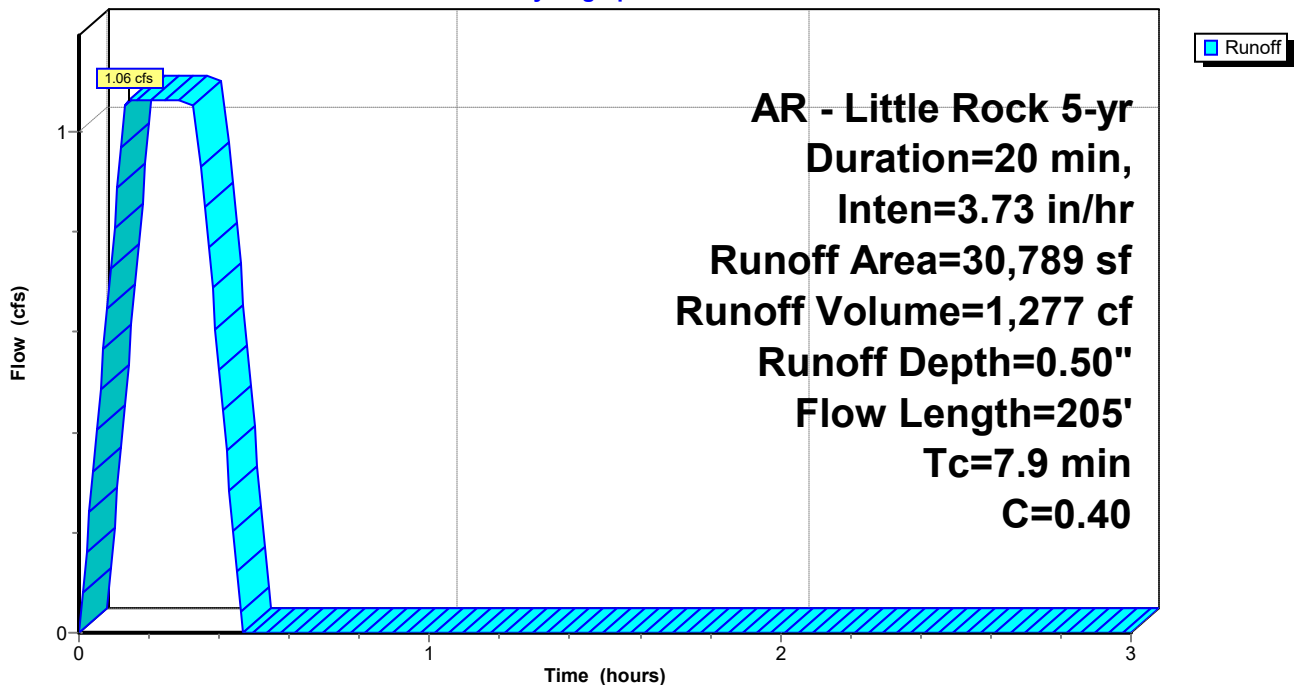

Goddard

Prepared by Phillip Lewis Engineering

HydroCAD® 10.20-5c s/n 12520 © 2023 HydroCAD Software Solutions LLC

AR - Little Rock 5-yr Duration=20 min, Inten=3.73 in/hr

Printed 3/25/2026

Summary for Subcatchment C3: Drainage Basin C3

Runoff = 0.29 cfs @ 0.09 hrs, Volume= 343 cf, Depth= 1.18"
 Routed to Pond CI-C3 : CI - C3

Runoff by Rational method, Rise/Fall=1.0/1.0 xTc, Time Span= 0.00-3.00 hrs, dt= 0.01 hrs
 AR - Little Rock 5-yr Duration=20 min, Inten=3.73 in/hr

Area (sf)	C	Description
0	0.40	Sod Yard
3,480	0.95	Paving, Sidewalks
3,480	0.95	Weighted Average
3,480		100.00% Impervious Area

Tc (min)	Length (feet)	Slope (ft/ft)	Velocity (ft/sec)	Capacity (cfs)	Description
0.3	22	0.0200	1.16		Sheet Flow, Sheet Flow Smooth surfaces n= 0.011 P2= 4.19"
0.0	10	0.0340	3.74		Shallow Concentrated Flow, Concentrated Flow Paved Kv= 20.3 fps
0.1	18	0.0390	4.01		Shallow Concentrated Flow, Concentrated Flow Paved Kv= 20.3 fps
0.6	147	0.0380	3.96		Shallow Concentrated Flow, Concentrated Flow Paved Kv= 20.3 fps
4.0	415		1.73		Direct Entry, Concentrated Flow (Min)
5.0	612	Total			

Subcatchment C3: Drainage Basin C3

Hydrograph

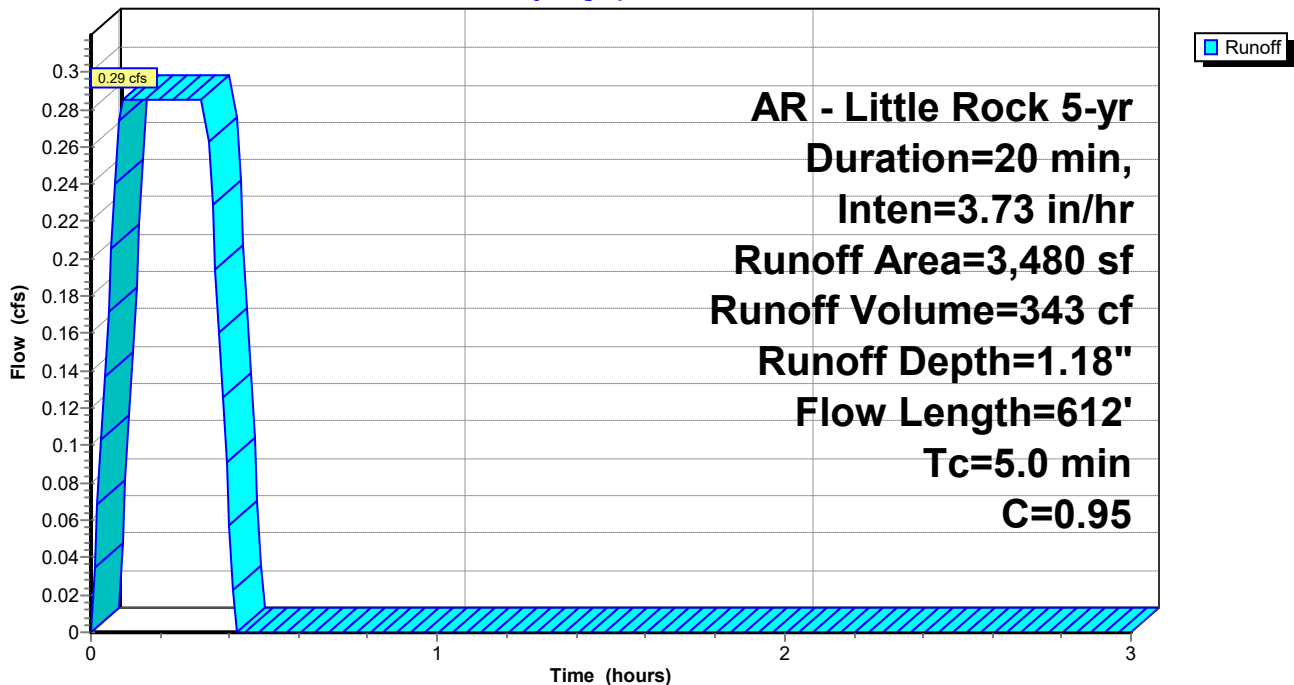

Goddard

Prepared by Phillip Lewis Engineering

HydroCAD® 10.20-5c s/n 12520 © 2023 HydroCAD Software Solutions LLC

AR - Little Rock 5-yr Duration=20 min, Inten=3.73 in/hr

Printed 3/25/2026

Summary for Subcatchment C4: Drainage Basin C4

Runoff = 0.55 cfs @ 0.09 hrs, Volume= 660 cf, Depth= 0.70"
Routed to Pond CI-C3 : CI - C3

Runoff by Rational method, Rise/Fall=1.0/1.0 xTc, Time Span= 0.00-3.00 hrs, dt= 0.01 hrs
AR - Little Rock 5-yr Duration=20 min, Inten=3.73 in/hr

Area (sf)	C	Description
8,130	0.40	Sod Yard
3,245	0.95	Paving, Sidewalks
11,375	0.56	Weighted Average
8,130		71.47% Pervious Area
3,245		28.53% Impervious Area

Tc (min)	Length (feet)	Slope (ft/ft)	Velocity (ft/sec)	Capacity (cfs)	Description
5.0	415		1.38		Direct Entry, Concentrated Flow (Min)

Subcatchment C4: Drainage Basin C4

Hydrograph

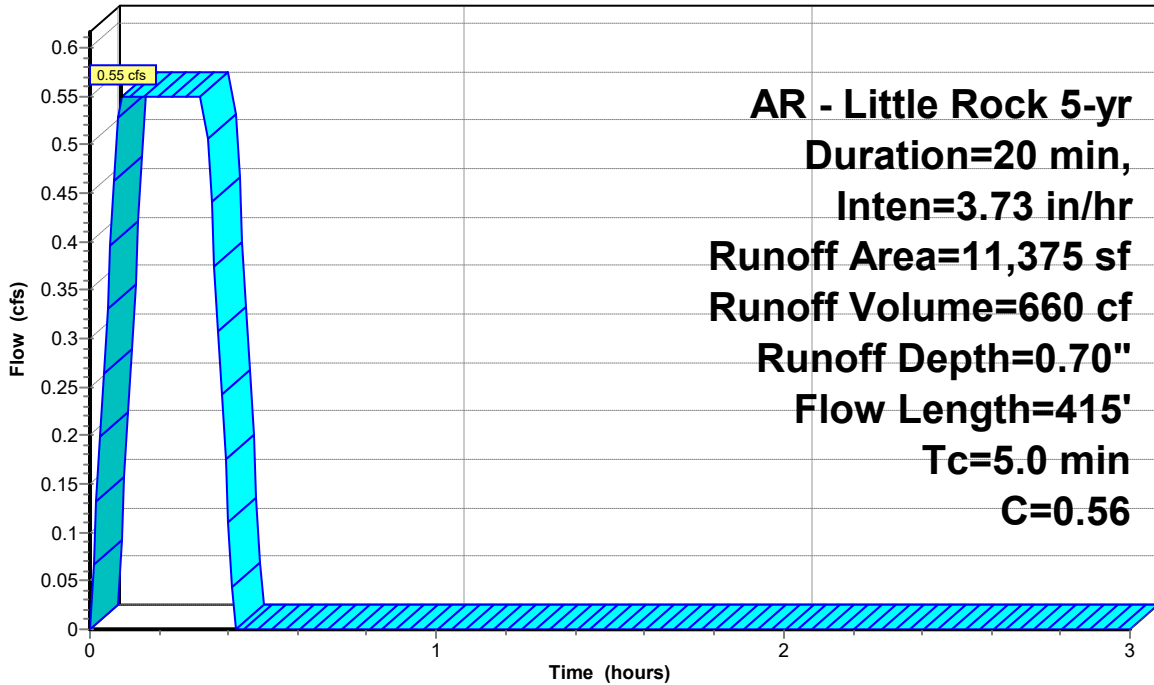

**AR - Little Rock 5-yr
Duration=20 min,
Inten=3.73 in/hr
Runoff Area=11,375 sf
Runoff Volume=660 cf
Runoff Depth=0.70"
Flow Length=415'
Tc=5.0 min
C=0.56**

Goddard

Prepared by Phillip Lewis Engineering

HydroCAD® 10.20-5c s/n 12520 © 2023 HydroCAD Software Solutions LLC

AR - Little Rock 5-yr Duration=20 min, Inten=3.73 in/hr

Printed 3/25/2026

Summary for Subcatchment C5: Drainage Basin C5

Runoff = 0.47 cfs @ 0.10 hrs, Volume= 569 cf, Depth= 1.02"
 Routed to Pond CI-C4 : CI - C4

Runoff by Rational method, Rise/Fall=1.0/1.0 xTc, Time Span= 0.00-3.00 hrs, dt= 0.01 hrs
 AR - Little Rock 5-yr Duration=20 min, Inten=3.73 in/hr

Area (sf)	C	Description
1,634	0.40	Sod Yard
5,061	0.95	Paving, Sidewalks
6,695	0.82	Weighted Average
1,634		24.41% Pervious Area
5,061		75.59% Impervious Area

Tc (min)	Length (feet)	Slope (ft/ft)	Velocity (ft/sec)	Capacity (cfs)	Description
0.6	5	0.2990	0.14		Sheet Flow, Sheet Flow Grass: Bermuda n= 0.410 P2= 4.19"
0.2	12	0.0130	0.87		Sheet Flow, Sheet Flow Smooth surfaces n= 0.011 P2= 4.19"
3.9	8	0.0070	0.03		Sheet Flow, Sheet Flow Grass: Bermuda n= 0.410 P2= 4.19"
0.5	58	0.0080	1.82		Shallow Concentrated Flow, Concentrated Flow Paved Kv= 20.3 fps
0.1	14	0.0280	3.40		Shallow Concentrated Flow, Concentrated Flow Paved Kv= 20.3 fps
0.1	23	0.0370	3.90		Shallow Concentrated Flow, Concentrated Flow Paved Kv= 20.3 fps
0.0	13	0.0940	6.22		Shallow Concentrated Flow, Concentrated Flow Paved Kv= 20.3 fps
0.0	13	0.0560	4.80		Shallow Concentrated Flow, Concentrated Flow Paved Kv= 20.3 fps
0.2	30	0.0180	2.72		Shallow Concentrated Flow, Concentrated Flow Paved Kv= 20.3 fps
5.6	176	Total			

Subcatchment C5: Drainage Basin C5

Hydrograph

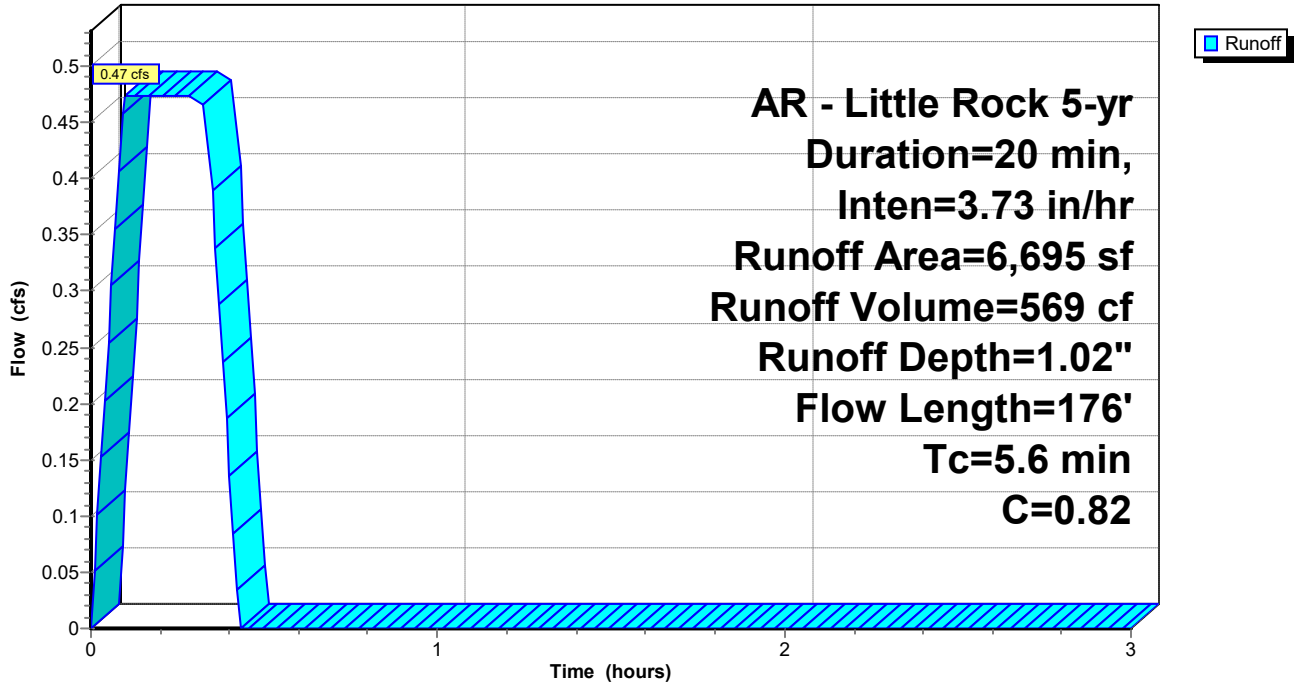

Goddard

Prepared by Phillip Lewis Engineering

HydroCAD® 10.20-5c s/n 12520 © 2023 HydroCAD Software Solutions LLC

AR - Little Rock 5-yr Duration=20 min, Inten=3.73 in/hr

Printed 3/25/2026

Summary for Subcatchment C6: Drainage Basin C6

Runoff = 0.23 cfs @ 0.09 hrs, Volume= 279 cf, Depth= 1.18"
 Routed to Pond CI-C5 : CI - C5

Runoff by Rational method, Rise/Fall=1.0/1.0 xTc, Time Span= 0.00-3.00 hrs, dt= 0.01 hrs
 AR - Little Rock 5-yr Duration=20 min, Inten=3.73 in/hr

Area (sf)	C	Description
0	0.40	Sod Yard
2,835	0.95	Paving, Sidewalks
2,835	0.95	Weighted Average
2,835		100.00% Impervious Area

Tc (min)	Length (feet)	Slope (ft/ft)	Velocity (ft/sec)	Capacity (cfs)	Description
0.3	22	0.0200	1.16		Sheet Flow, Sheet Flow Smooth surfaces n= 0.011 P2= 4.19"
0.2	19	0.0100	2.03		Shallow Concentrated Flow, Concentrated Flow Paved Kv= 20.3 fps
0.1	17	0.0170	2.65		Shallow Concentrated Flow, Concentrated Flow Paved Kv= 20.3 fps
0.1	26	0.0360	3.85		Shallow Concentrated Flow, Concentrated Flow Paved Kv= 20.3 fps
0.1	28	0.0610	5.01		Shallow Concentrated Flow, Concentrated Flow Paved Kv= 20.3 fps
0.1	27	0.0610	5.01		Shallow Concentrated Flow, Concentrated Flow Paved Kv= 20.3 fps
4.1	415		1.69		Direct Entry, Concentrated Flow (Min)
5.0	554	Total			

Subcatchment C6: Drainage Basin C6

Hydrograph

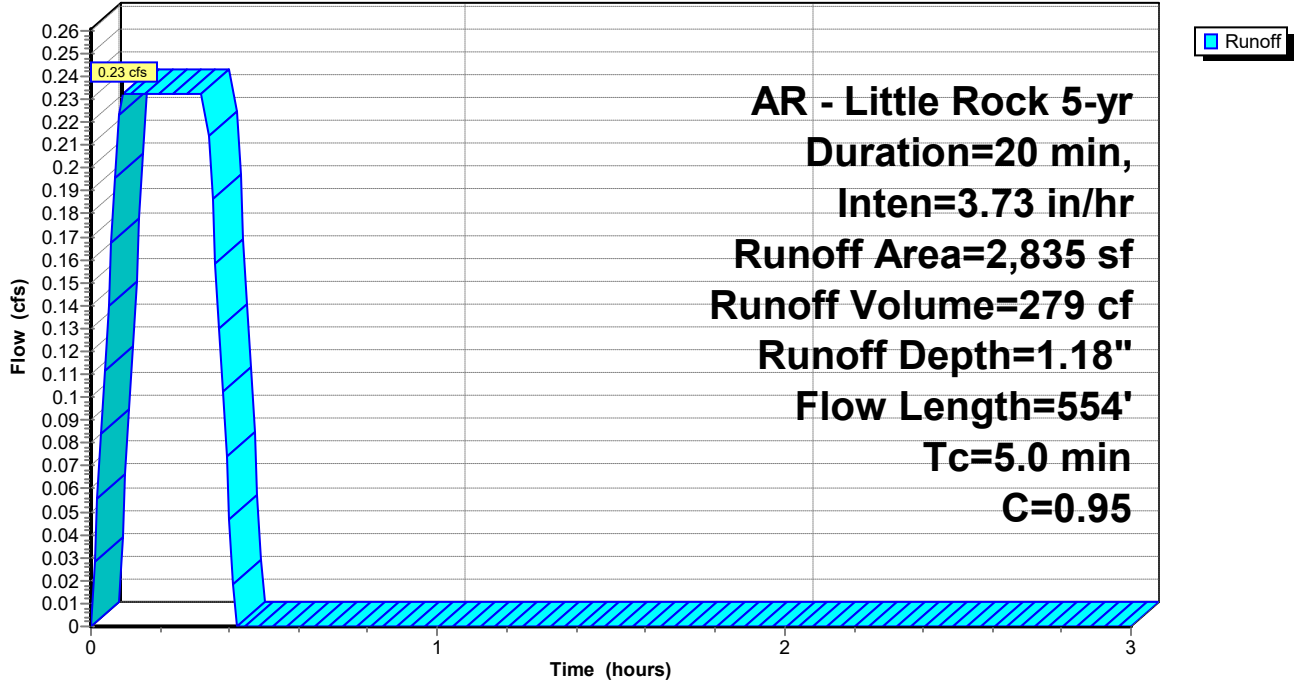

Goddard

Prepared by Phillip Lewis Engineering

HydroCAD® 10.20-5c s/n 12520 © 2023 HydroCAD Software Solutions LLC

AR - Little Rock 5-yr Duration=20 min, Inten=3.73 in/hr

Printed 3/25/2026

Summary for Subcatchment C7: Drainage Basin C7

Runoff = 0.13 cfs @ 0.09 hrs, Volume= 157 cf, Depth= 1.18"
 Routed to Pond CI-D1 : CI - D1

Runoff by Rational method, Rise/Fall=1.0/1.0 xTc, Time Span= 0.00-3.00 hrs, dt= 0.01 hrs
 AR - Little Rock 5-yr Duration=20 min, Inten=3.73 in/hr

Area (sf)	C	Description
0	0.40	Sod Yard
1,597	0.95	Paving, Sidewalks
1,597	0.95	Weighted Average
1,597		100.00% Impervious Area

Tc (min)	Length (feet)	Slope (ft/ft)	Velocity (ft/sec)	Capacity (cfs)	Description
0.3	19	0.0200	1.13		Sheet Flow, Sheet Flow Smooth surfaces n= 0.011 P2= 4.19"
0.1	16	0.0540	4.72		Shallow Concentrated Flow, Concentrated Flow Paved Kv= 20.3 fps
0.3	81	0.0580	4.89		Shallow Concentrated Flow, Concentrated Flow Paved Kv= 20.3 fps
4.3	415		1.61		Direct Entry, Concentrated Flow (Min)
5.0	531	Total			

Subcatchment C7: Drainage Basin C7

Hydrograph

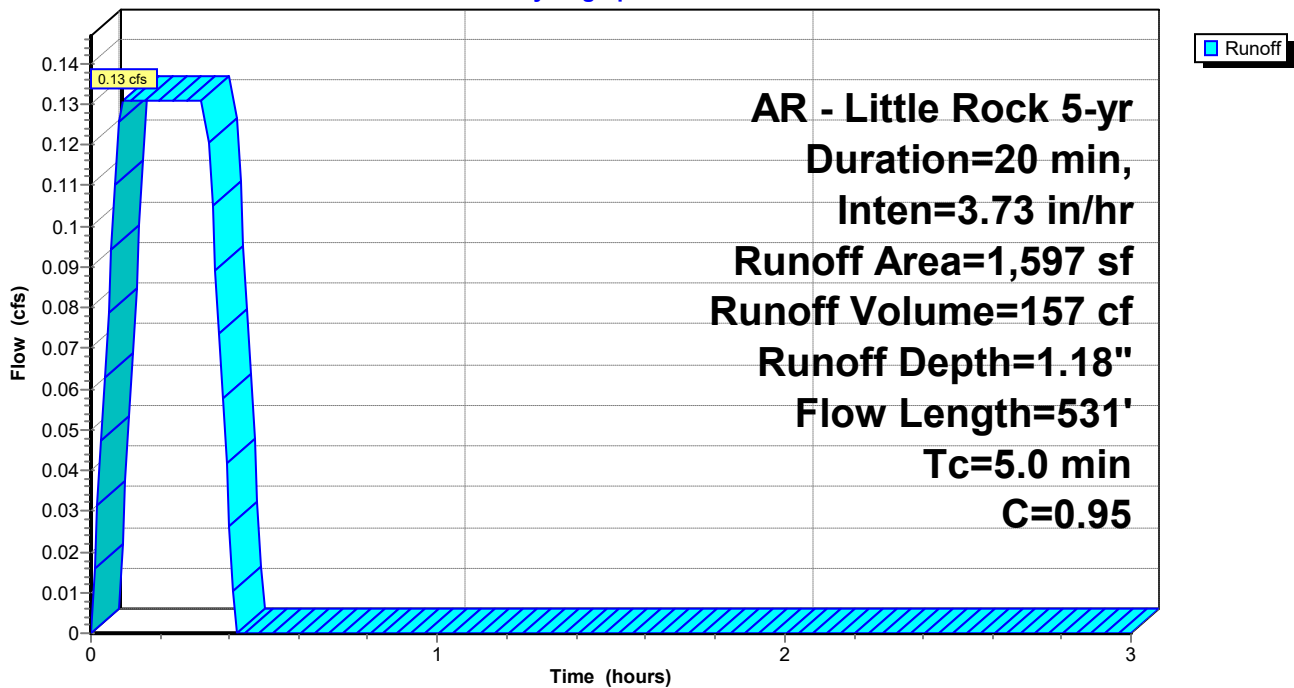

Goddard

Prepared by Phillip Lewis Engineering

HydroCAD® 10.20-5c s/n 12520 © 2023 HydroCAD Software Solutions LLC

AR - Little Rock 5-yr Duration=20 min, Inten=3.73 in/hr

Printed 3/25/2026

Summary for Subcatchment C8: Drainage Basin C8

Runoff = 0.13 cfs @ 0.09 hrs, Volume= 152 cf, Depth= 1.18"
 Routed to Pond CI-D2 : CI - D2

Runoff by Rational method, Rise/Fall=1.0/1.0 xTc, Time Span= 0.00-3.00 hrs, dt= 0.01 hrs
 AR - Little Rock 5-yr Duration=20 min, Inten=3.73 in/hr

Area (sf)	C	Description
0	0.40	Sod Yard
1,548	0.95	Paving, Sidewalks
1,548	0.95	Weighted Average
1,548		100.00% Impervious Area

Tc (min)	Length (feet)	Slope (ft/ft)	Velocity (ft/sec)	Capacity (cfs)	Description
0.3	18	0.0200	1.12		Sheet Flow, Sheet Flow Smooth surfaces n= 0.011 P2= 4.19"
0.3	94	0.0610	5.01		Shallow Concentrated Flow, Concentrated Flow Paved Kv= 20.3 fps
4.4	415		1.57		Direct Entry, Concentrated Flow (Min)
5.0	527	Total			

Subcatchment C8: Drainage Basin C8

Hydrograph

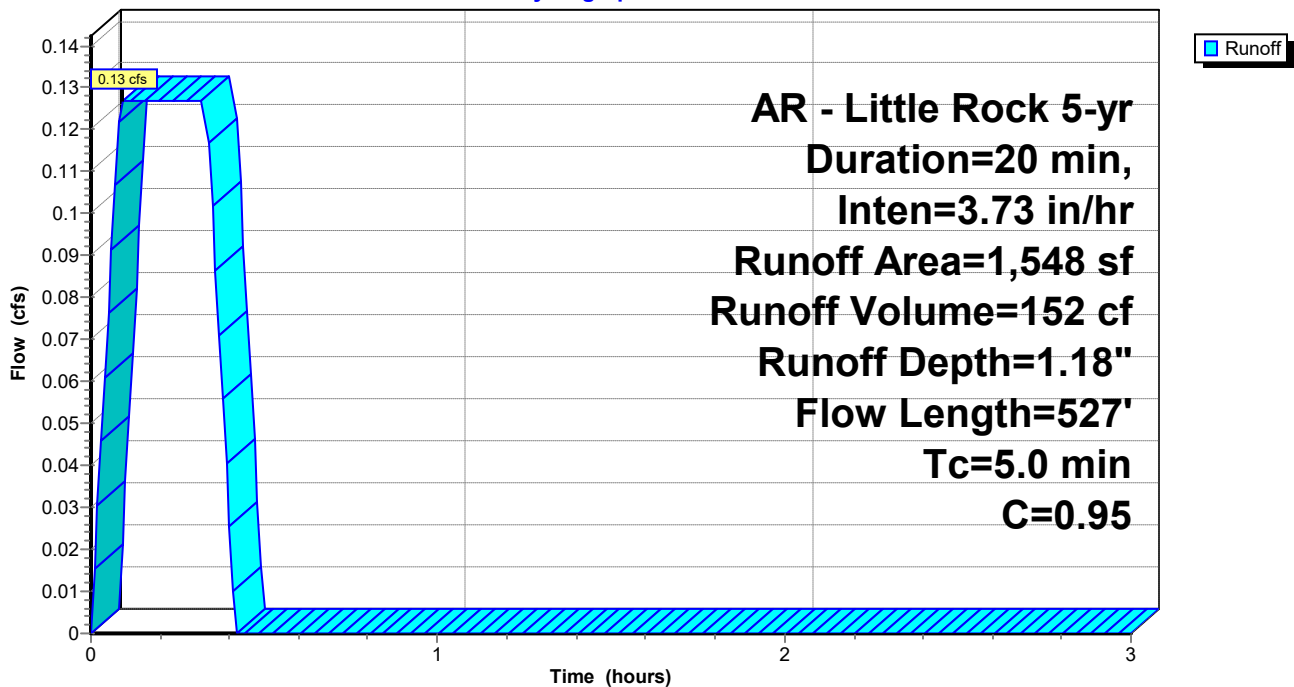

Goddard

Prepared by Phillip Lewis Engineering

HydroCAD® 10.20-5c s/n 12520 © 2023 HydroCAD Software Solutions LLC

AR - Little Rock 5-yr Duration=20 min, Inten=3.73 in/hr

Printed 3/25/2026

Summary for Subcatchment C9: Drainage Basin C9

Runoff = 0.92 cfs @ 0.09 hrs, Volume= 1,103 cf, Depth= 0.96"
 Routed to Pond CI-C6 : CI - C6

Runoff by Rational method, Rise/Fall=1.0/1.0 xTc, Time Span= 0.00-3.00 hrs, dt= 0.01 hrs
 AR - Little Rock 5-yr Duration=20 min, Inten=3.73 in/hr

Area (sf)	C	Description
4,456	0.40	Sod Yard
9,361	0.95	Paving, Sidewalks
13,817	0.77	Weighted Average
4,456		32.25% Pervious Area
9,361		67.75% Impervious Area

Tc (min)	Length (feet)	Slope (ft/ft)	Velocity (ft/sec)	Capacity (cfs)	Description
1.2	100	0.0140	1.36		Sheet Flow, Sheet Flow Smooth surfaces n= 0.011 P2= 4.19"
0.1	13	0.0150	2.49		Shallow Concentrated Flow, Concentrated Flow Paved Kv= 20.3 fps
0.1	23	0.0160	2.57		Shallow Concentrated Flow, Concentrated Flow Paved Kv= 20.3 fps
0.1	7	0.0050	1.44		Shallow Concentrated Flow, Concentrated Flow Paved Kv= 20.3 fps
0.1	8	0.0100	2.03		Shallow Concentrated Flow, Concentrated Flow Paved Kv= 20.3 fps
0.2	41	0.0420	4.16		Shallow Concentrated Flow, Concentrated Flow Paved Kv= 20.3 fps
0.1	41	0.0540	4.72		Shallow Concentrated Flow, Concentrated Flow Paved Kv= 20.3 fps
0.2	61	0.0520	4.63		Shallow Concentrated Flow, Concentrated Flow Paved Kv= 20.3 fps
2.9	415		2.39		Direct Entry, Concentrated Flow (Min)
5.0	709	Total			

Subcatchment C9: Drainage Basin C9

Hydrograph

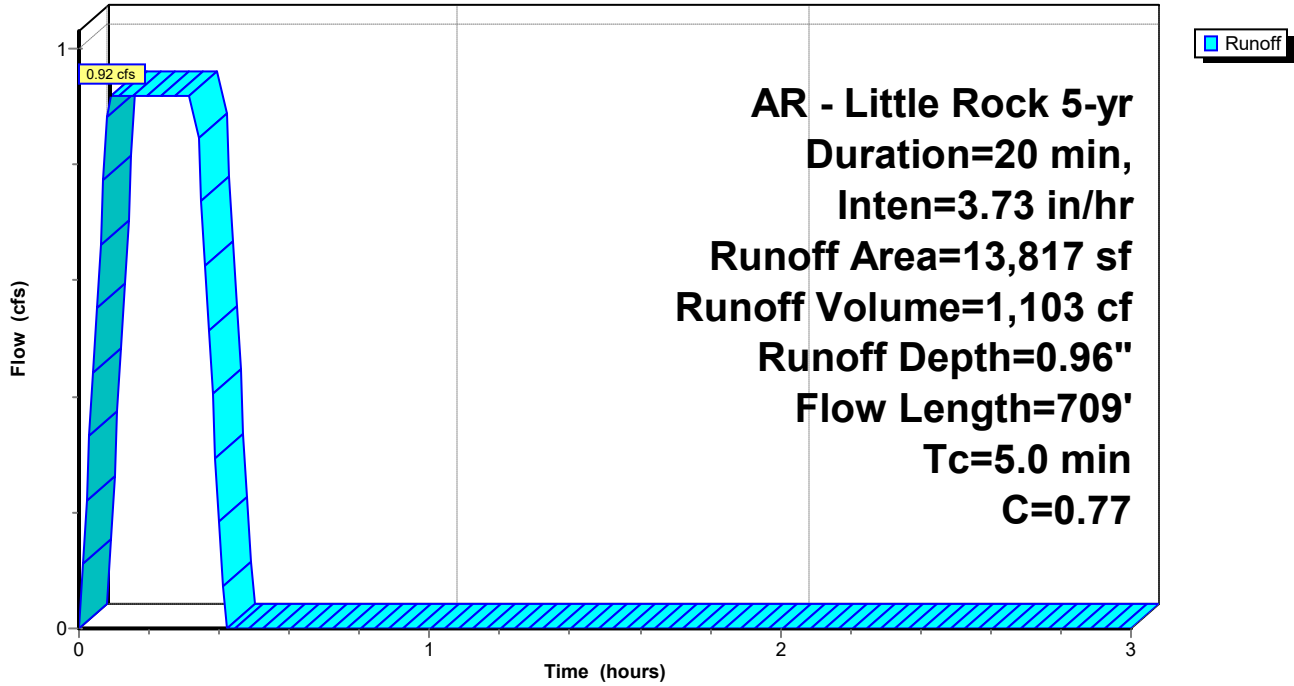

Summary for Pond CI-A1: CI - A1

Inflow Area = 19,493 sf, 74.78% Impervious, Inflow Depth = 1.04" for 5-yr event
Inflow = 1.41 cfs @ 0.09 hrs, Volume= 1,697 cf
Primary = 1.41 cfs @ 0.09 hrs, Volume= 1,697 cf, Atten= 0%, Lag= 0.0 min
Routed to Pond JB-A2 : JB - A2

Routing by Stor-Ind method, Time Span= 0.00-3.00 hrs, dt= 0.01 hrs

Pond CI-A1: CI - A1

Hydrograph

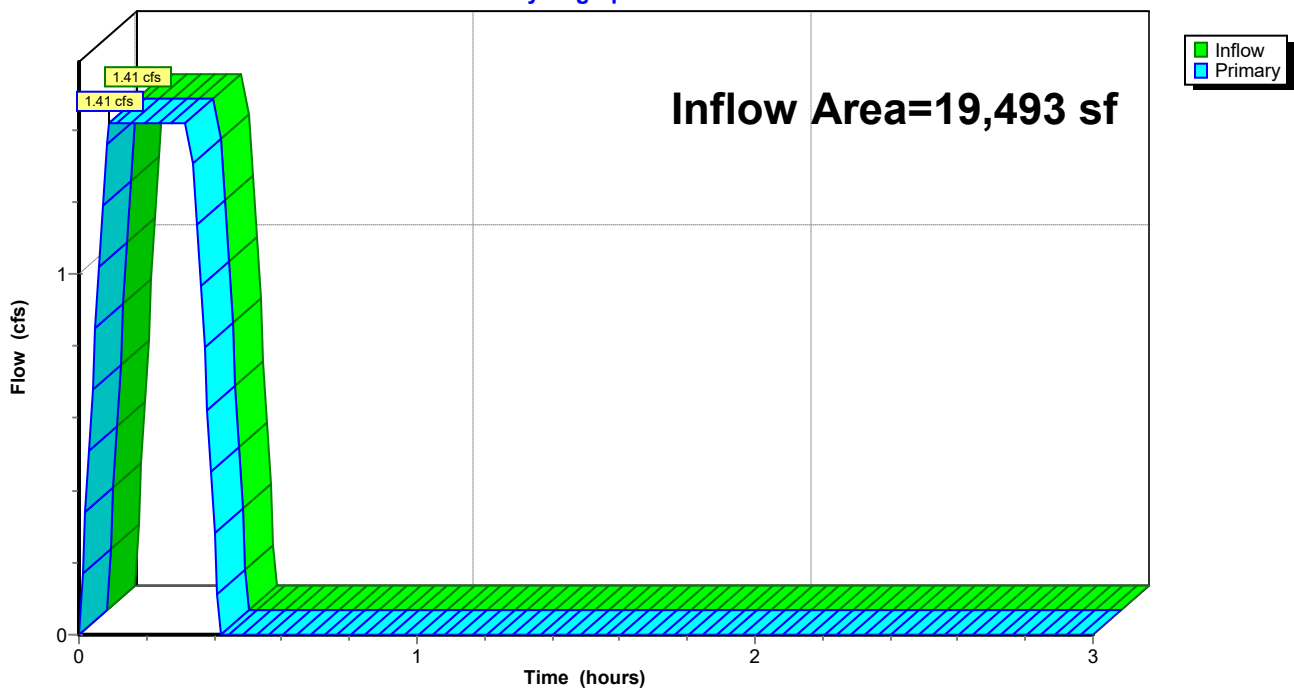

Summary for Pond CI-A3: CI - A3

Inflow Area = 52,824 sf, 61.20% Impervious, Inflow Depth = 0.97" for 5-yr event
Inflow = 3.56 cfs @ 0.17 hrs, Volume= 4,266 cf
Primary = 3.56 cfs @ 0.17 hrs, Volume= 4,266 cf, Atten= 0%, Lag= 0.0 min
Routed to Pond CI-A4 : CI - A4

Routing by Stor-Ind method, Time Span= 0.00-3.00 hrs, dt= 0.01 hrs

Pond CI-A3: CI - A3

Hydrograph

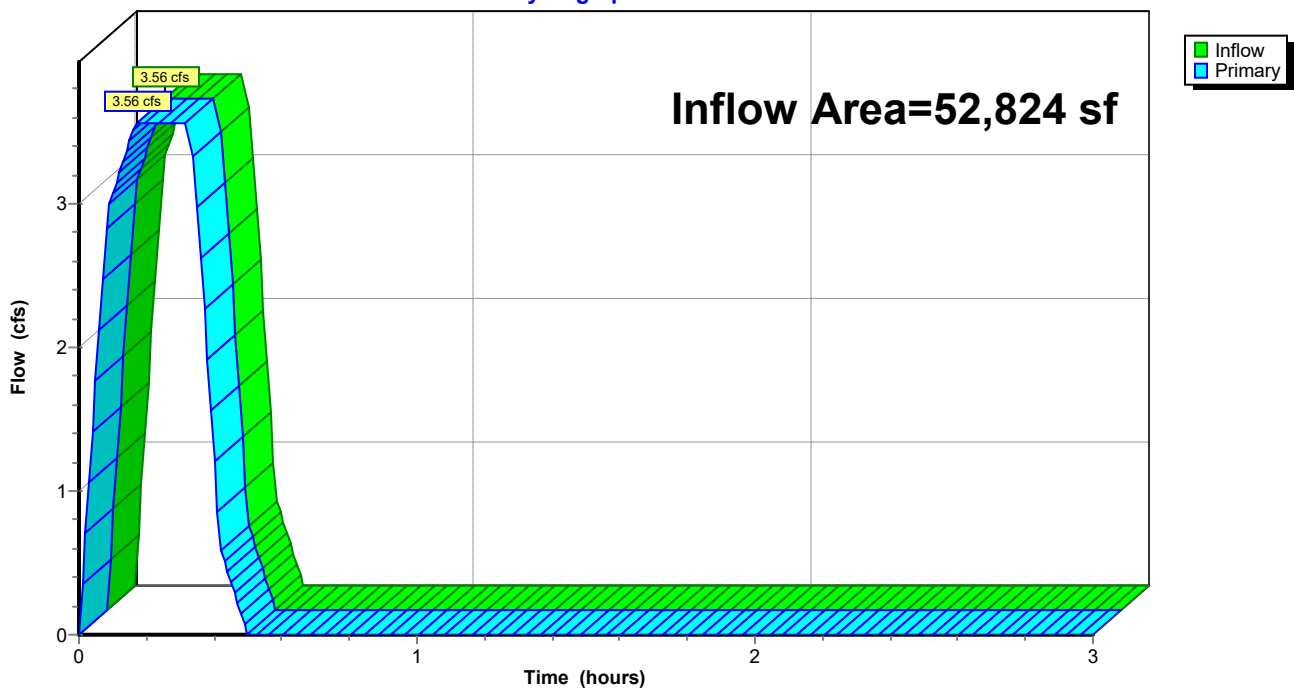

Summary for Pond CI-A4: CI - A4

Inflow Area = 75,210 sf, 60.06% Impervious, Inflow Depth = 0.96" for 5-yr event
Inflow = 5.02 cfs @ 0.24 hrs, Volume= 6,021 cf
Primary = 5.02 cfs @ 0.24 hrs, Volume= 6,021 cf, Atten= 0%, Lag= 0.0 min
Routed to Pond CI-A5 : CI - A5

Routing by Stor-Ind method, Time Span= 0.00-3.00 hrs, dt= 0.01 hrs

Pond CI-A4: CI - A4

Hydrograph

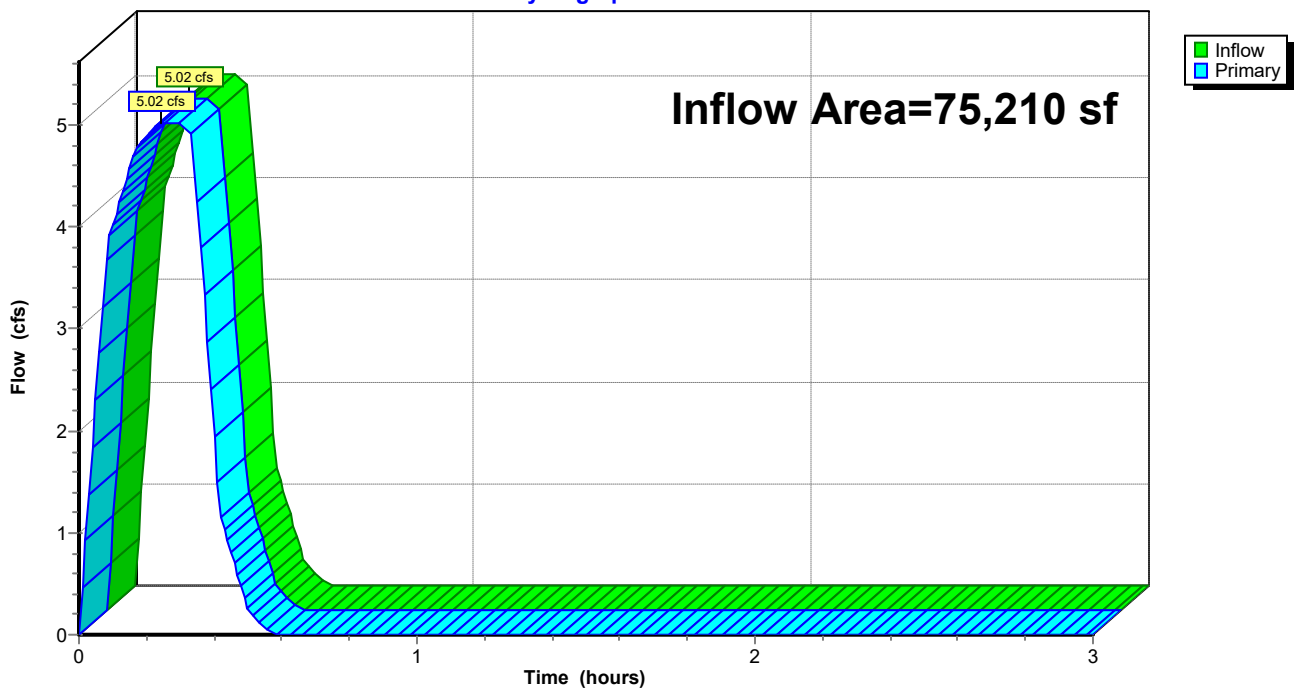

Summary for Pond CI-A5: CI - A5

Inflow Area = 97,235 sf, 62.81% Impervious, Inflow Depth = 0.97" for 5-yr event
Inflow = 6.54 cfs @ 0.27 hrs, Volume= 7,847 cf
Primary = 6.54 cfs @ 0.27 hrs, Volume= 7,847 cf, Atten= 0%, Lag= 0.0 min
Routed to Pond DP : Existing North Detention Pond

Routing by Stor-Ind method, Time Span= 0.00-3.00 hrs, dt= 0.01 hrs

Pond CI-A5: CI - A5

Hydrograph

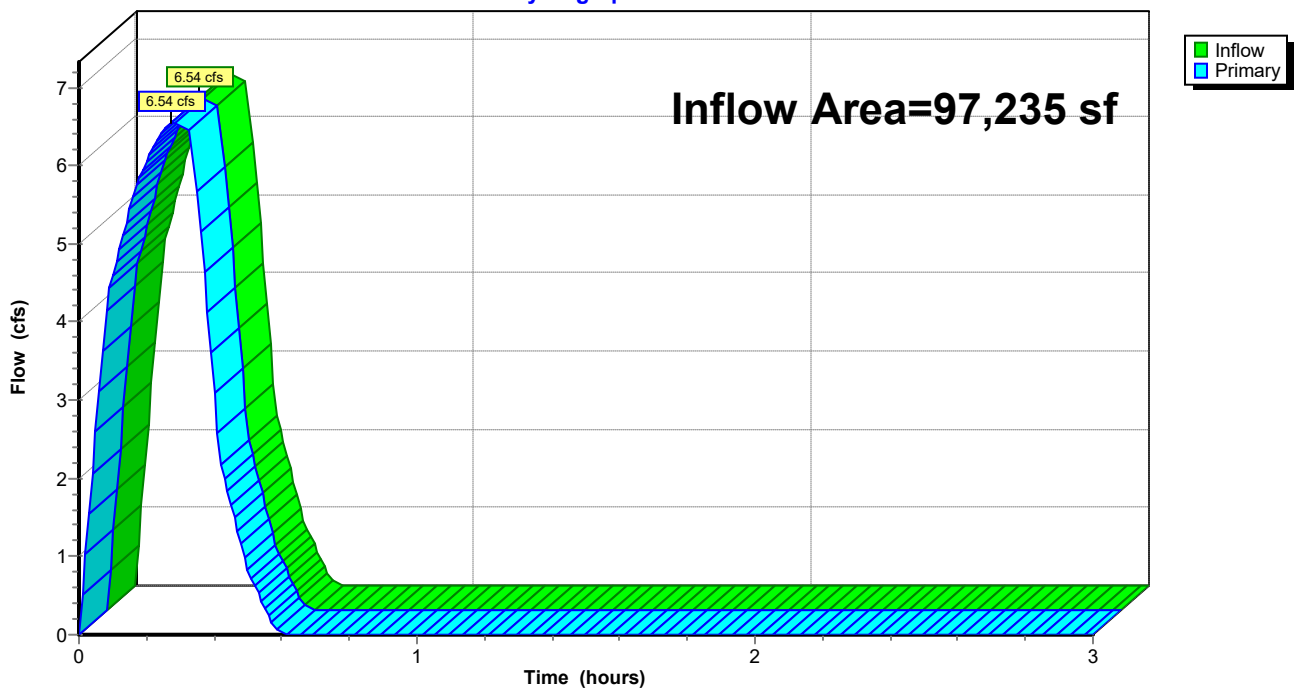

Summary for Pond CI-B2: CI - B2

Inflow Area = 22,169 sf, 29.72% Impervious, Inflow Depth = 0.80" for 5-yr event
Inflow = 1.23 cfs @ 0.17 hrs, Volume= 1,470 cf
Primary = 1.23 cfs @ 0.17 hrs, Volume= 1,470 cf, Atten= 0%, Lag= 0.0 min
Routed to Pond JB-A2 : JB - A2

Routing by Stor-Ind method, Time Span= 0.00-3.00 hrs, dt= 0.01 hrs

Pond CI-B2: CI - B2

Hydrograph

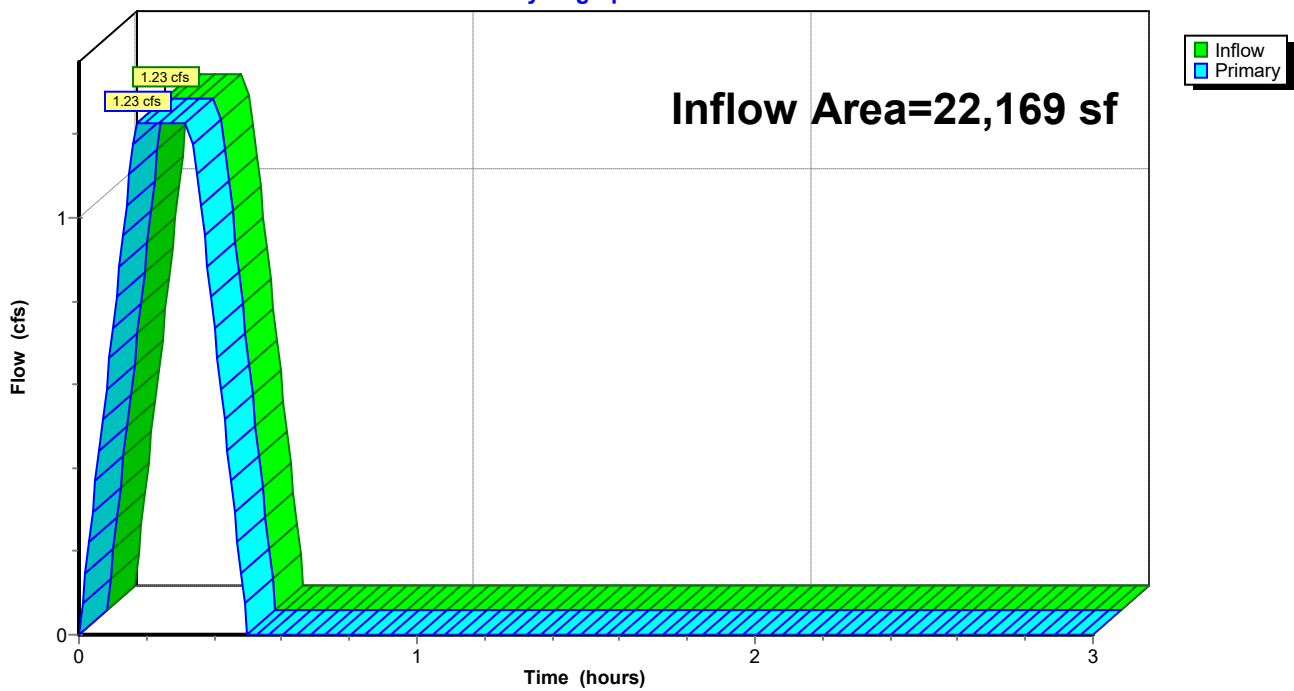

Summary for Pond CI-C1: CI - C1

Inflow Area = 20,337 sf, 69.83% Impervious, Inflow Depth = 0.97" for 5-yr event
Inflow = 1.37 cfs @ 0.09 hrs, Volume= 1,643 cf
Primary = 1.37 cfs @ 0.09 hrs, Volume= 1,643 cf, Atten= 0%, Lag= 0.0 min
Routed to Pond CI-C2 : CI - C2

Routing by Stor-Ind method, Time Span= 0.00-3.00 hrs, dt= 0.01 hrs

Pond CI-C1: CI - C1

Hydrograph

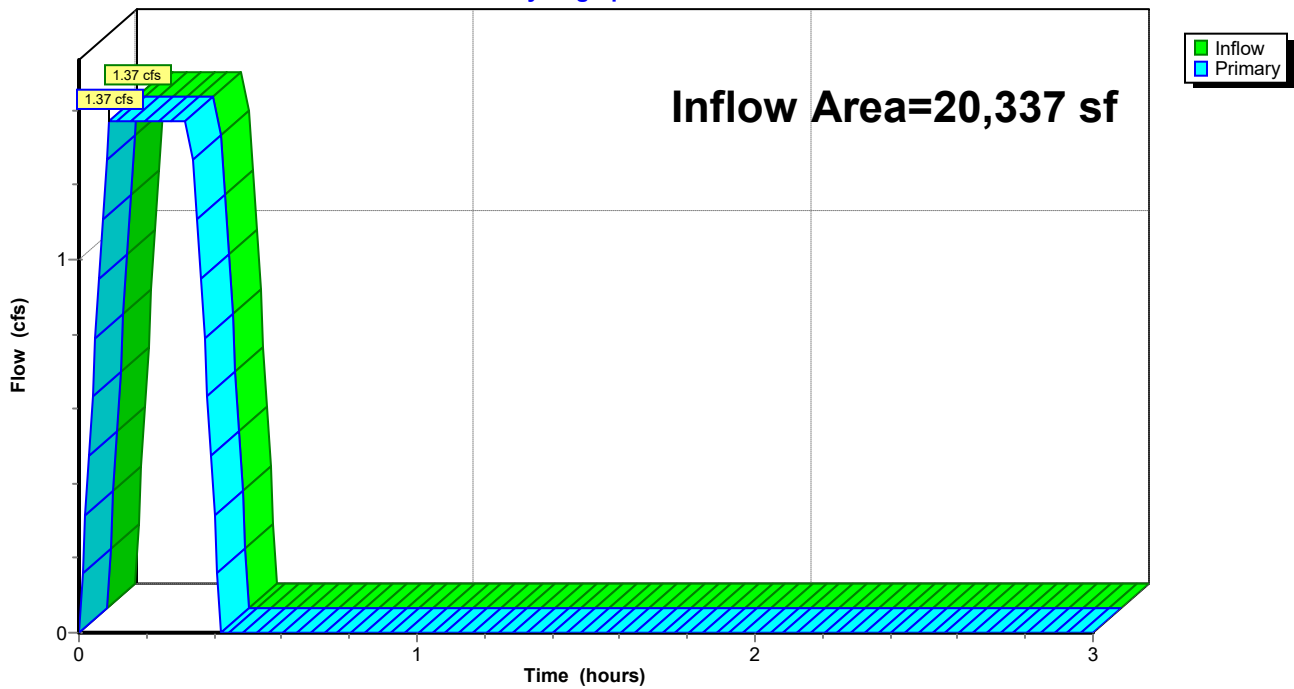

Summary for Pond CI-C2: CI - C2

Inflow Area = 54,676 sf, 67.97% Impervious, Inflow Depth = 0.96" for 5-yr event
Inflow = 3.65 cfs @ 0.09 hrs, Volume= 4,383 cf
Primary = 3.65 cfs @ 0.09 hrs, Volume= 4,383 cf, Atten= 0%, Lag= 0.0 min
Routed to Pond CI-C3 : CI - C3

Routing by Stor-Ind method, Time Span= 0.00-3.00 hrs, dt= 0.01 hrs

Pond CI-C2: CI - C2

Hydrograph

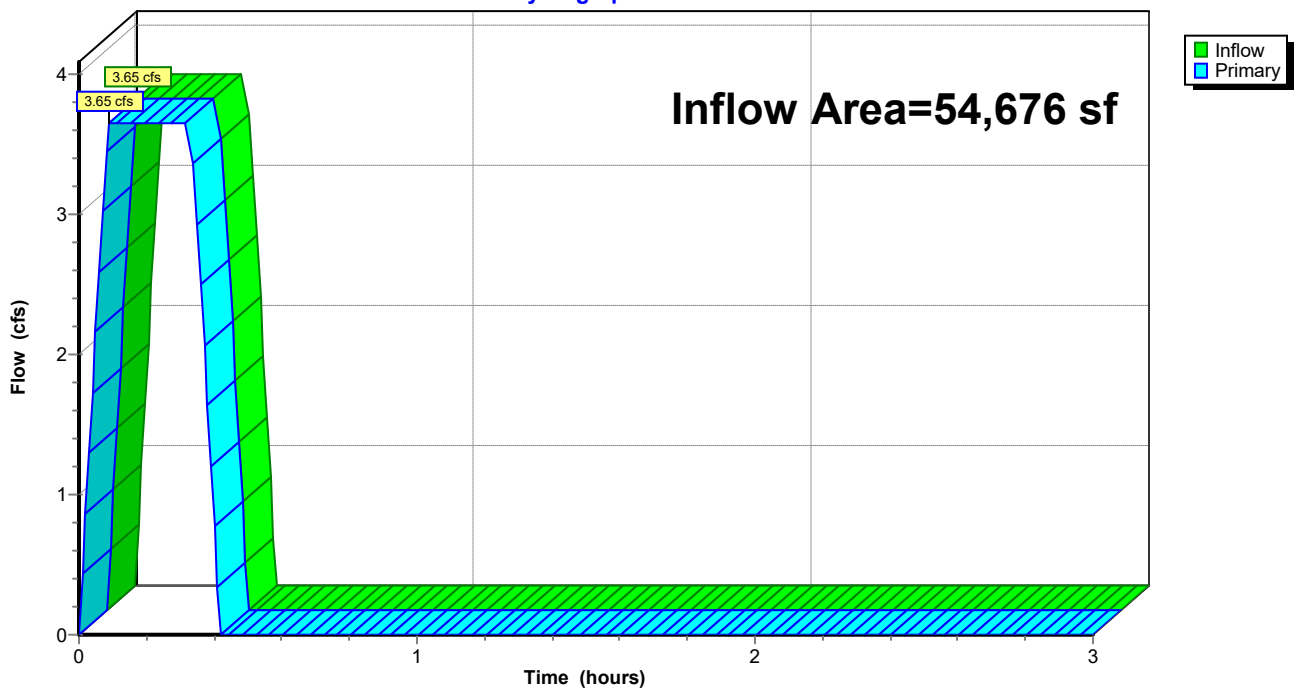

Summary for Pond CI-C3: CI - C3

Inflow Area = 69,531 sf, 63.12% Impervious, Inflow Depth = 0.93" for 5-yr event
Inflow = 4.49 cfs @ 0.09 hrs, Volume= 5,386 cf
Primary = 4.49 cfs @ 0.09 hrs, Volume= 5,386 cf, Atten= 0%, Lag= 0.0 min
Routed to Pond CI-C4 : CI - C4

Routing by Stor-Ind method, Time Span= 0.00-3.00 hrs, dt= 0.01 hrs

Pond CI-C3: CI - C3

Hydrograph

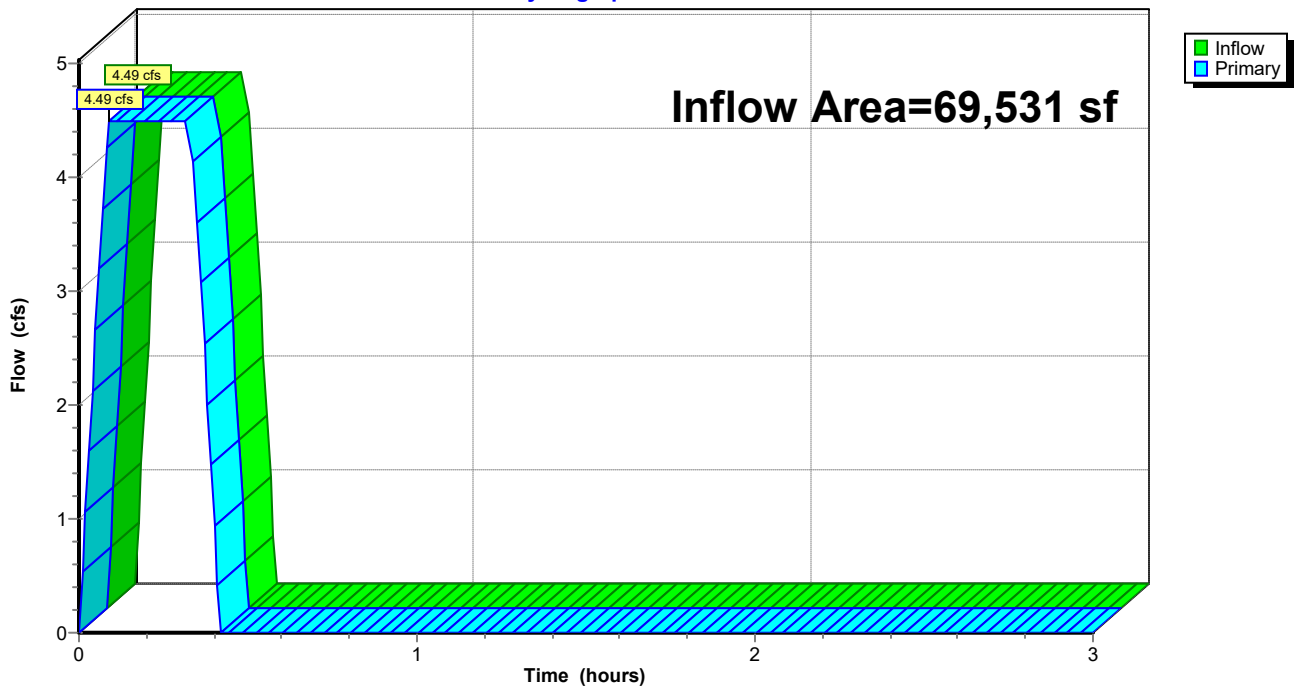

Summary for Pond CI-C4: CI - C4

Inflow Area = 76,226 sf, 64.22% Impervious, Inflow Depth = 0.94" for 5-yr event
Inflow = 4.97 cfs @ 0.10 hrs, Volume= 5,955 cf
Primary = 4.97 cfs @ 0.10 hrs, Volume= 5,955 cf, Atten= 0%, Lag= 0.0 min
Routed to Pond CI-C5 : CI - C5

Routing by Stor-Ind method, Time Span= 0.00-3.00 hrs, dt= 0.01 hrs

Pond CI-C4: CI - C4

Hydrograph

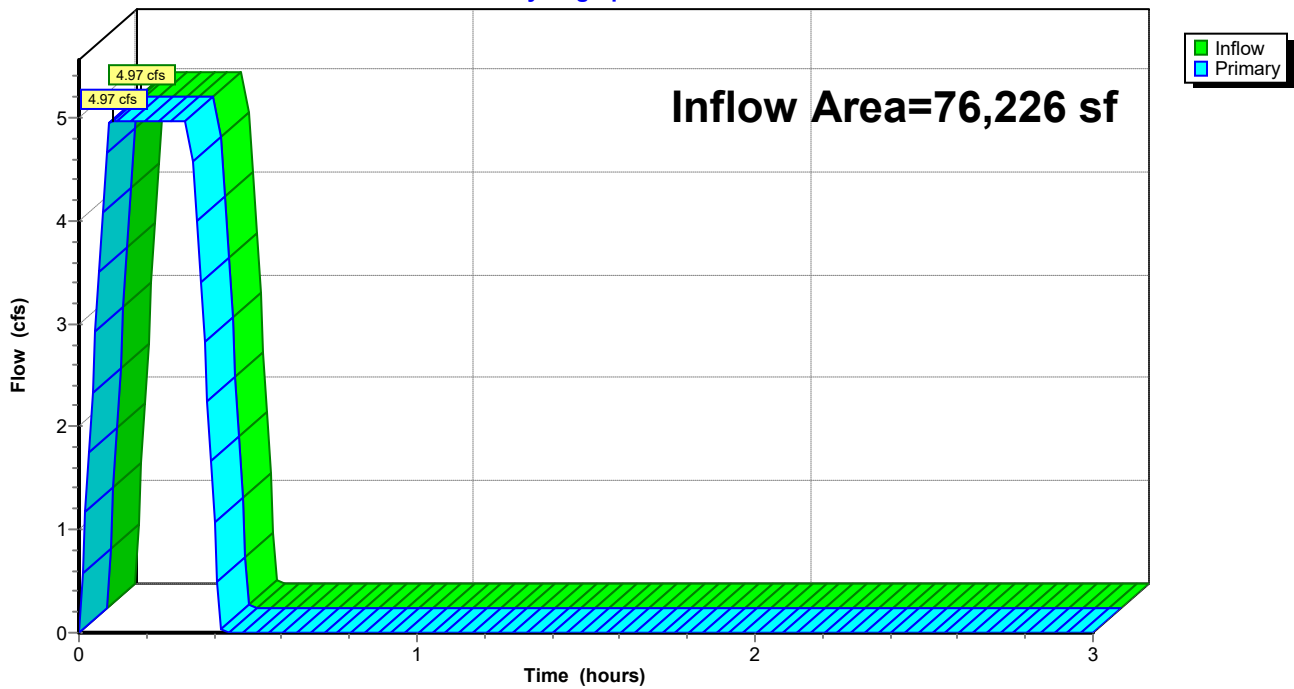

Summary for Pond CI-C5: CI - C5

Inflow Area = 79,061 sf, 65.50% Impervious, Inflow Depth = 0.95" for 5-yr event
Inflow = 5.20 cfs @ 0.10 hrs, Volume= 6,234 cf
Primary = 5.20 cfs @ 0.10 hrs, Volume= 6,234 cf, Atten= 0%, Lag= 0.0 min
Routed to Pond CI-C6 : CI - C6

Routing by Stor-Ind method, Time Span= 0.00-3.00 hrs, dt= 0.01 hrs

Pond CI-C5: CI - C5

Hydrograph

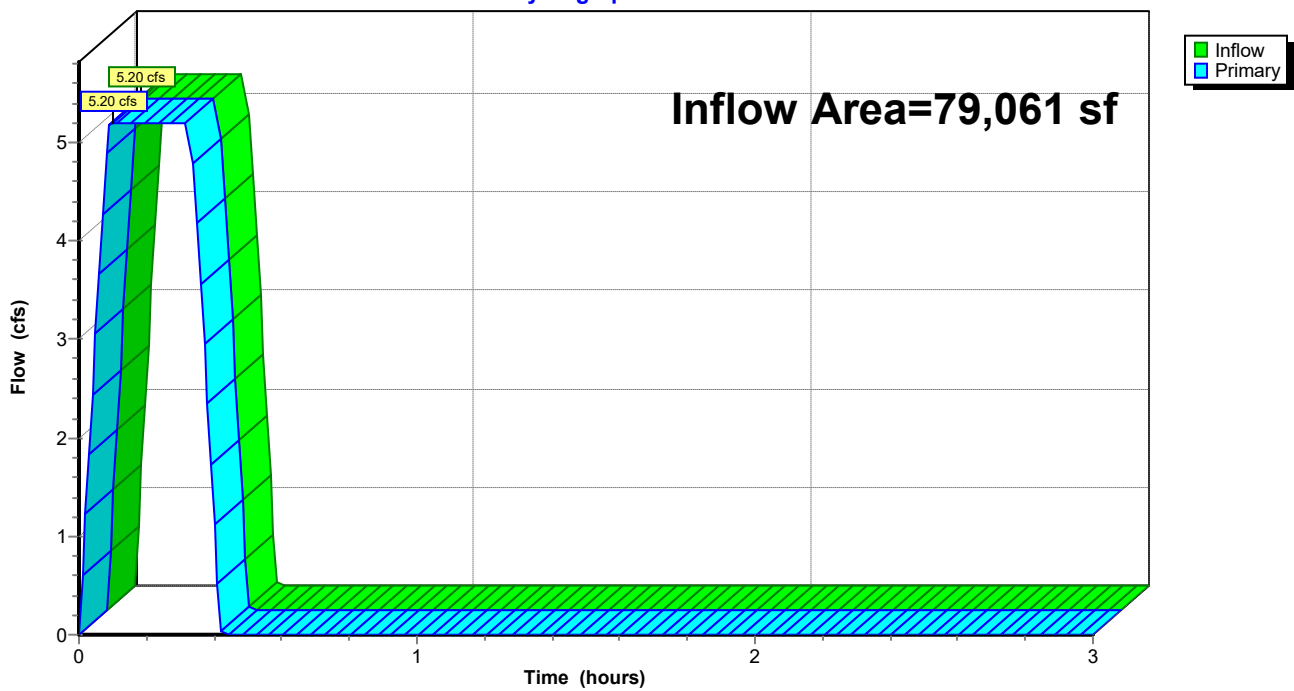

Summary for Pond CI-C6: CI - C6

Inflow Area = 96,023 sf, 66.95% Impervious, Inflow Depth = 0.96" for 5-yr event
Inflow = 6.37 cfs @ 0.10 hrs, Volume= 7,646 cf
Primary = 6.37 cfs @ 0.10 hrs, Volume= 7,646 cf, Atten= 0%, Lag= 0.0 min
Routed to Pond CI-C7 : CI - C7

Routing by Stor-Ind method, Time Span= 0.00-3.00 hrs, dt= 0.01 hrs

Pond CI-C6: CI - C6

Hydrograph

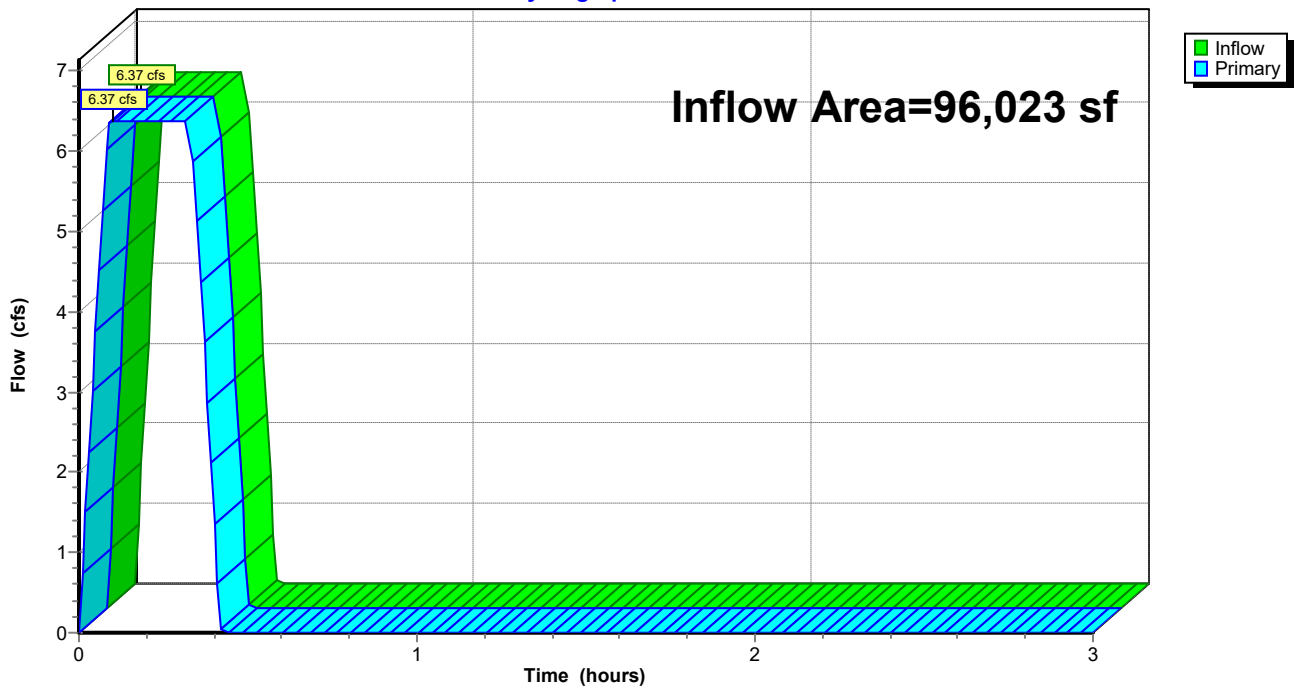

Summary for Pond CI-C7: CI - C7

Inflow Area = 133,272 sf, 67.70% Impervious, Inflow Depth = 0.96" for 5-yr event
Inflow = 8.90 cfs @ 0.10 hrs, Volume= 10,681 cf
Primary = 8.90 cfs @ 0.10 hrs, Volume= 10,681 cf, Atten= 0%, Lag= 0.0 min
Routed to Pond DP : Existing North Detention Pond

Routing by Stor-Ind method, Time Span= 0.00-3.00 hrs, dt= 0.01 hrs

Pond CI-C7: CI - C7

Hydrograph

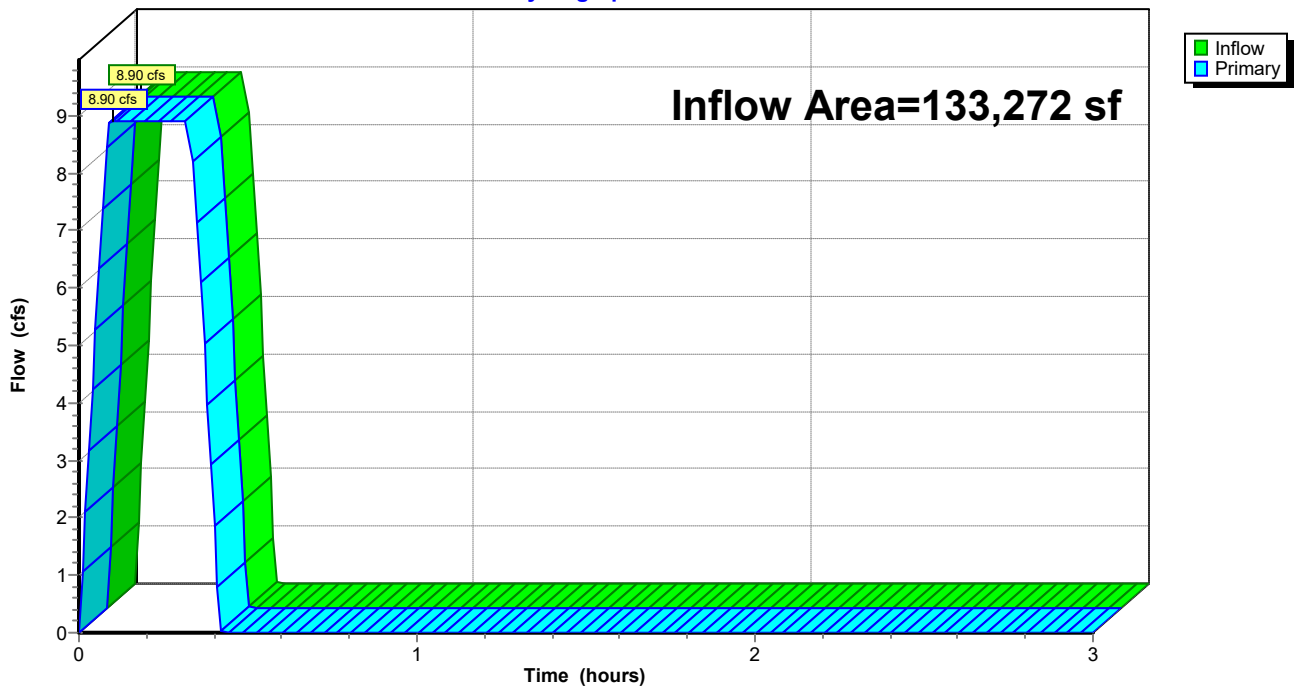

Summary for Pond CI-D1: CI - D1

Inflow Area = 1,597 sf, 100.00% Impervious, Inflow Depth = 1.18" for 5-yr event
Inflow = 0.13 cfs @ 0.09 hrs, Volume= 157 cf
Primary = 0.13 cfs @ 0.09 hrs, Volume= 157 cf, Atten= 0%, Lag= 0.0 min
Routed to Pond CI-D2 : CI - D2

Routing by Stor-Ind method, Time Span= 0.00-3.00 hrs, dt= 0.01 hrs

Pond CI-D1: CI - D1

Hydrograph

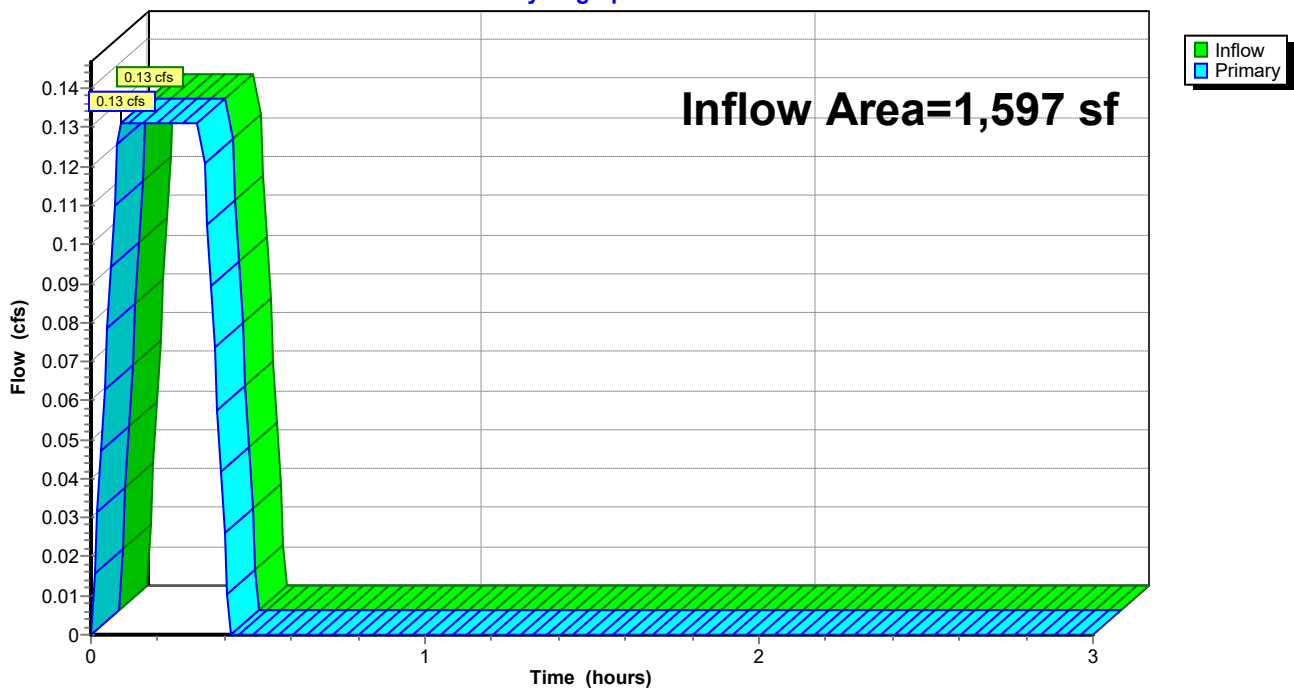

Summary for Pond CI-D2: CI - D2

Inflow Area = 3,145 sf, 100.00% Impervious, Inflow Depth = 1.18" for 5-yr event
Inflow = 0.26 cfs @ 0.09 hrs, Volume= 310 cf
Primary = 0.26 cfs @ 0.09 hrs, Volume= 310 cf, Atten= 0%, Lag= 0.0 min
Routed to Pond CI-C6 : CI - C6

Routing by Stor-Ind method, Time Span= 0.00-3.00 hrs, dt= 0.01 hrs

Pond CI-D2: CI - D2

Hydrograph

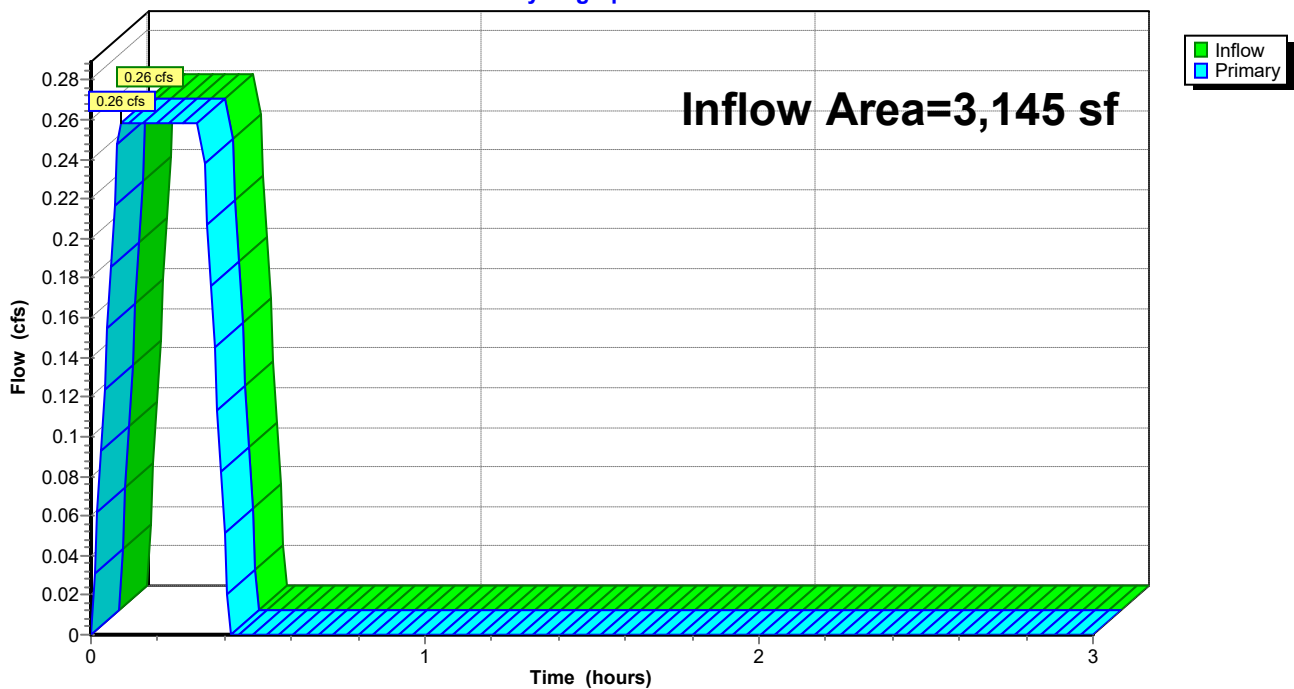

Summary for Pond CI-E1: CI - E1

Inflow Area = 5,408 sf, 77.35% Impervious, Inflow Depth = 1.03" for 5-yr event
Inflow = 0.39 cfs @ 0.09 hrs, Volume= 465 cf
Primary = 0.39 cfs @ 0.09 hrs, Volume= 465 cf, Atten= 0%, Lag= 0.0 min
Routed to Pond CI-E2 : CI - E2

Routing by Stor-Ind method, Time Span= 0.00-3.00 hrs, dt= 0.01 hrs

Pond CI-E1: CI - E1

Hydrograph

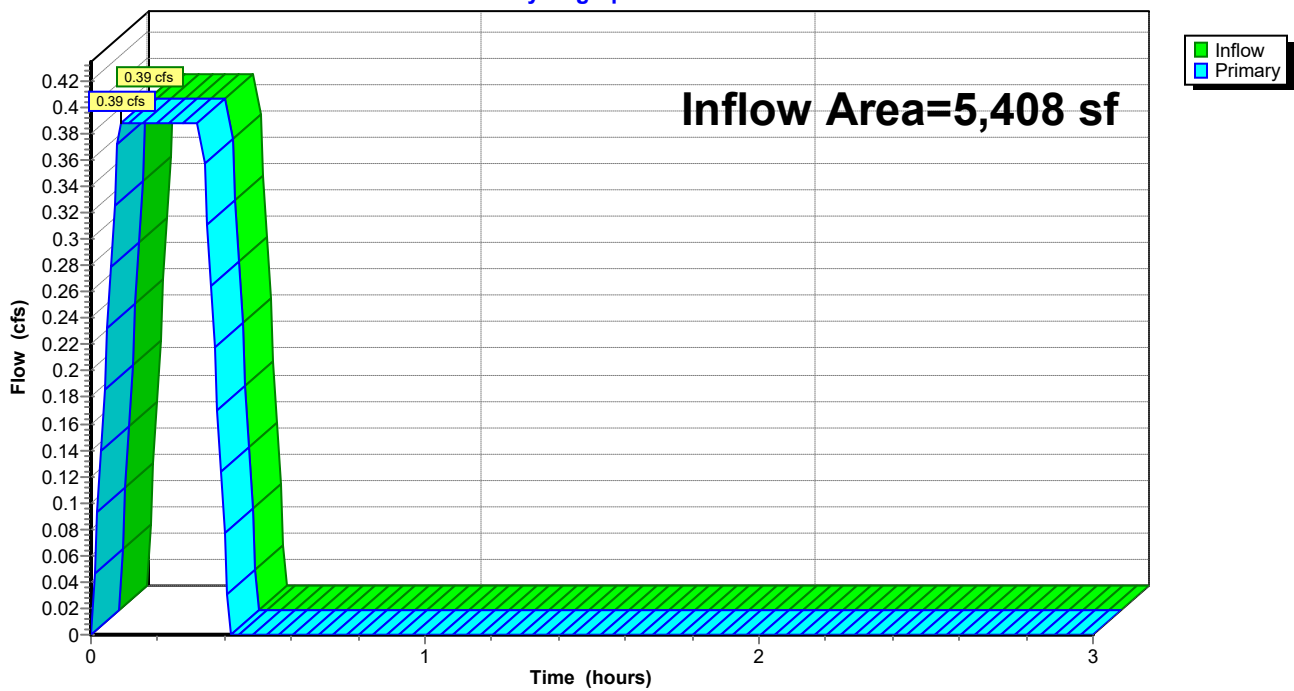

Summary for Pond CI-E2: CI - E2

Inflow Area = 11,591 sf, 64.62% Impervious, Inflow Depth = 0.94" for 5-yr event
Inflow = 0.76 cfs @ 0.09 hrs, Volume= 907 cf
Primary = 0.76 cfs @ 0.09 hrs, Volume= 907 cf, Atten= 0%, Lag= 0.0 min
Routed to Pond CI-C7 : CI - C7

Routing by Stor-Ind method, Time Span= 0.00-3.00 hrs, dt= 0.01 hrs

Pond CI-E2: CI - E2

Hydrograph

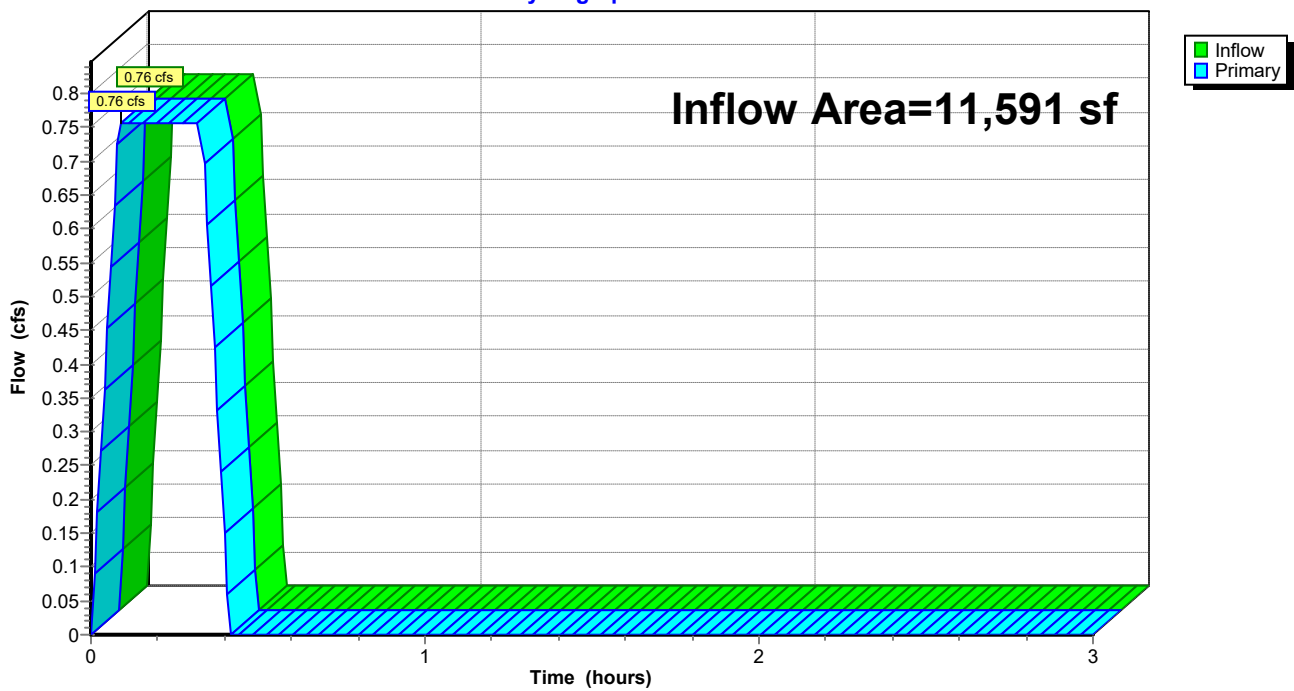

Goddard

AR - Little Rock 5-yr Duration=20 min, Inten=3.73 in/hr

Prepared by Phillip Lewis Engineering

Printed 3/25/2026

HydroCAD® 10.20-5c s/n 12520 © 2023 HydroCAD Software Solutions LLC

Summary for Pond DP: Existing North Detention Pond

Inflow Area = 322,783 sf, 53.09% Impervious, Inflow Depth = 0.87" for 5-yr event
 Inflow = 19.58 cfs @ 0.27 hrs, Volume= 23,486 cf
 Outflow = 9.62 cfs @ 0.38 hrs, Volume= 23,486 cf, Atten= 51%, Lag= 6.9 min
 Primary = 9.62 cfs @ 0.38 hrs, Volume= 23,486 cf
 Routed to Link FINAL : APPROX DISCHARGE

Routing by Stor-Ind method, Time Span= 0.00-3.00 hrs, dt= 0.01 hrs
 Peak Elev= 382.84' @ 0.38 hrs Storage= 13,568 cf

Plug-Flow detention time= 17.2 min calculated for 23,408 cf (100% of inflow)
 Center-of-Mass det. time= 17.3 min (30.8 - 13.5)

Volume	Invert	Avail.Storage	Storage Description
#1	381.17'	72,742 cf	Custom Stage Data Listed below

Elevation (feet)	Inc.Store (cubic-feet)	Cum.Store (cubic-feet)
381.17	0	0
381.50	200	200
382.00	1,825	2,025
382.50	5,265	7,290
383.00	9,300	16,590
383.50	13,733	30,323
384.00	18,578	48,901
384.50	23,841	72,742

Device	Routing	Invert	Outlet Devices
#1	Primary	384.16'	5.0' long Sharp-Crested Rectangular Weir 2 End Contraction(s)
#2	Primary	381.17'	1.7' long Sharp-Crested Rectangular Weir 2 End Contraction(s)

Primary OutFlow Max=9.62 cfs @ 0.38 hrs HW=382.84' (Free Discharge)

1=Sharp-Crested Rectangular Weir (Controls 0.00 cfs)

2=Sharp-Crested Rectangular Weir (Weir Controls 9.62 cfs @ 4.22 fps)

Pond DP: Existing North Detention Pond

Hydrograph

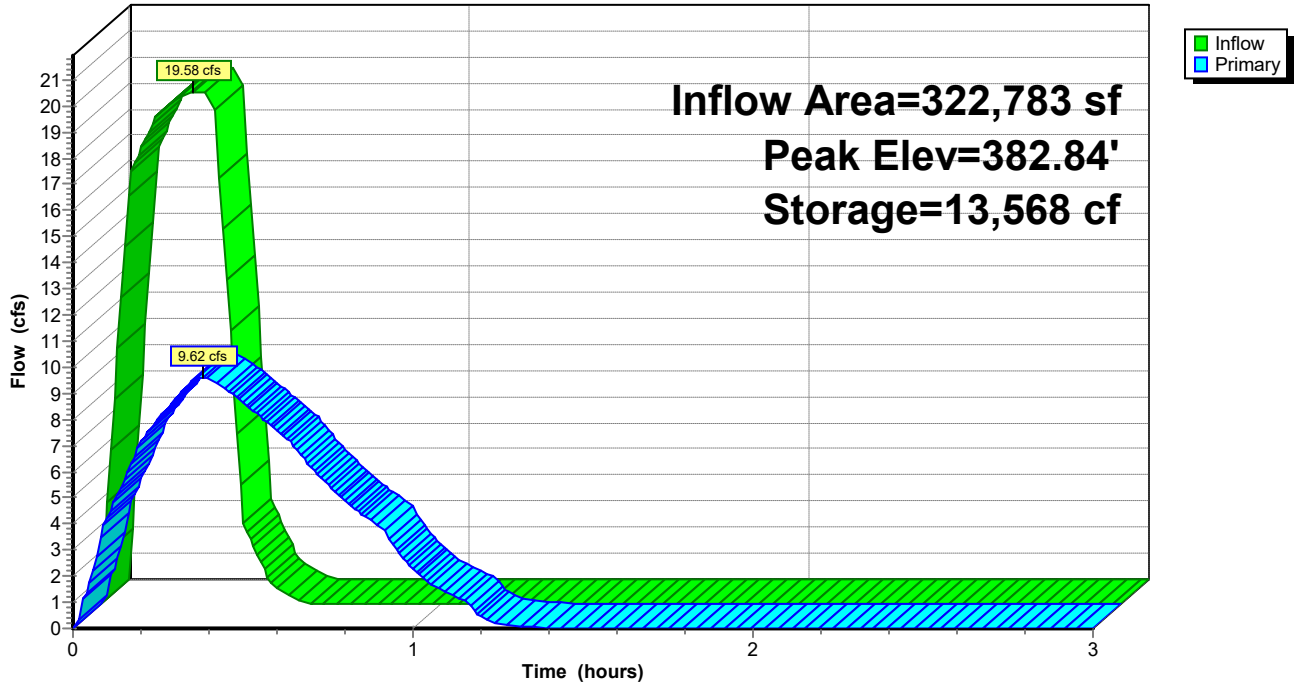

Summary for Pond JB-A2: JB - A2

Inflow Area = 50,937 sf, 59.76% Impervious, Inflow Depth = 0.96" for 5-yr event
Inflow = 3.40 cfs @ 0.17 hrs, Volume= 4,080 cf
Primary = 3.40 cfs @ 0.17 hrs, Volume= 4,080 cf, Atten= 0%, Lag= 0.0 min
Routed to Pond CI-A3 : CI - A3

Routing by Stor-Ind method, Time Span= 0.00-3.00 hrs, dt= 0.01 hrs

Pond JB-A2: JB - A2

Hydrograph

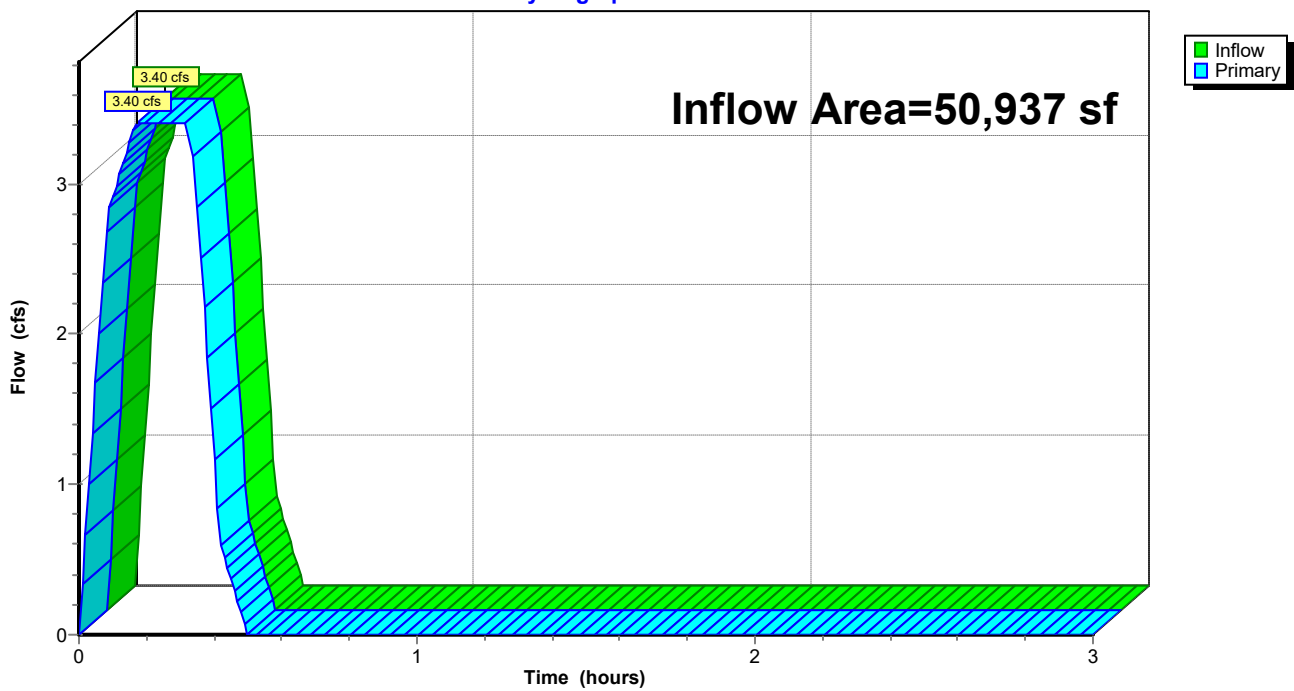

Summary for Link FINAL: APPROX DISCHARGE

Inflow Area = 509,184 sf, 38.62% Impervious, Inflow Depth = 0.80" for 5-yr event
Inflow = 17.90 cfs @ 0.33 hrs, Volume= 33,908 cf
Primary = 17.90 cfs @ 0.33 hrs, Volume= 33,908 cf, Atten= 0%, Lag= 0.0 min

Primary outflow = Inflow, Time Span= 0.00-3.00 hrs, dt= 0.01 hrs

Link FINAL: APPROX DISCHARGE

Hydrograph

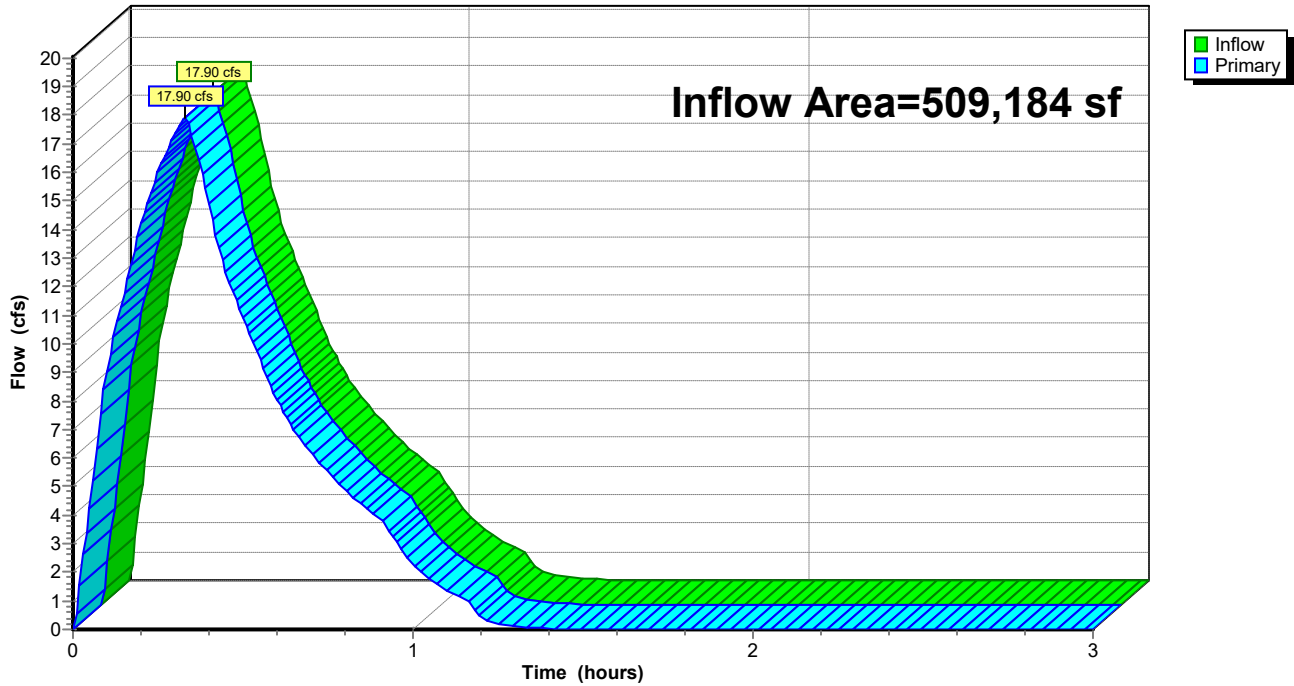

Goddard

Prepared by Phillip Lewis Engineering

HydroCAD® 10.20-5c s/n 12520 © 2023 HydroCAD Software Solutions LLC

AR - Little Rock 10-yr Duration=20 min, Inten=4.22 in/hr

Printed 3/25/2026

Summary for Subcatchment B1: Drainage Basin B1

Runoff = 3.87 cfs @ 0.31 hrs, Volume= 4,644 cf, Depth= 0.75"
 Routed to Link FINAL : APPROX DISCHARGE

Runoff by Rational method, Rise/Fall=1.0/1.0 xTc, Time Span= 0.00-3.00 hrs, dt= 0.01 hrs
 AR - Little Rock 10-yr Duration=20 min, Inten=4.22 in/hr

Area (sf)	C	Description
9,241	0.51	Sod Yard
602	0.95	Paving, Sidewalks
64,924	0.53	Undeveloped
74,767	0.53	Weighted Average
74,165		99.19% Pervious Area
602		0.81% Impervious Area

Tc (min)	Length (feet)	Slope (ft/ft)	Velocity (ft/sec)	Capacity (cfs)	Description
0.1	6	0.0180	0.86		Sheet Flow, Sheet Flow Smooth surfaces n= 0.011 P2= 4.19"
2.6	25	0.1920	0.16		Sheet Flow, Sheet Flow Grass: Bermuda n= 0.410 P2= 4.19"
11.9	75	0.0370	0.11		Sheet Flow, Sheet Flow Grass: Bermuda n= 0.410 P2= 4.19"
0.7	58	0.0370	1.35		Shallow Concentrated Flow, Concentrated Flow Short Grass Pasture Kv= 7.0 fps
1.6	141	0.0420	1.43		Shallow Concentrated Flow, Concentrated Flow Short Grass Pasture Kv= 7.0 fps
0.7	60	0.0400	1.40		Shallow Concentrated Flow, Concentrated Flow Short Grass Pasture Kv= 7.0 fps
0.9	77	0.0420	1.43		Shallow Concentrated Flow, Concentrated Flow Short Grass Pasture Kv= 7.0 fps
18.5	442	Total			

Subcatchment B1: Drainage Basin B1

Hydrograph

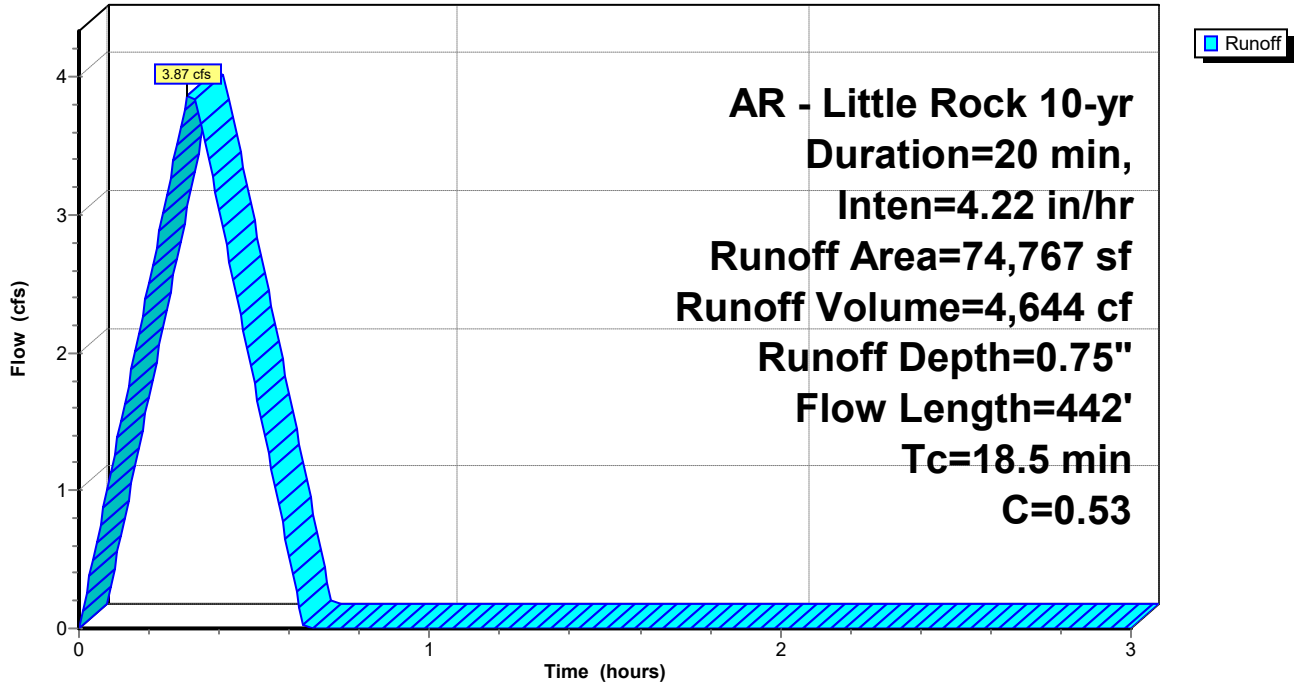

Goddard

Prepared by Phillip Lewis Engineering

HydroCAD® 10.20-5c s/n 12520 © 2023 HydroCAD Software Solutions LLC

AR - Little Rock 10-yr Duration=20 min, Inten=4.22 in/hr

Printed 3/25/2026

Summary for Subcatchment B2: Drainage Basin B2

Runoff = 0.34 cfs @ 0.10 hrs, Volume= 412 cf, Depth= 0.73"
 Routed to Link FINAL : APPROX DISCHARGE

Runoff by Rational method, Rise/Fall=1.0/1.0 xTc, Time Span= 0.00-3.00 hrs, dt= 0.01 hrs
 AR - Little Rock 10-yr Duration=20 min, Inten=4.22 in/hr

Area (sf)	C	Description
6,595	0.51	Sod Yard
167	0.95	Paving, Sidewalks
6,762	0.52	Weighted Average
6,595		97.53% Pervious Area
167		2.47% Impervious Area

Tc (min)	Length (feet)	Slope (ft/ft)	Velocity (ft/sec)	Capacity (cfs)	Description
0.1	6	0.0180	0.86		Sheet Flow, Sheet Flow Smooth surfaces n= 0.011 P2= 4.19"
5.7	55	0.1240	0.16		Sheet Flow, Sheet Flow Grass: Bermuda n= 0.410 P2= 4.19"
5.8	61	Total			

Subcatchment B2: Drainage Basin B2

Hydrograph

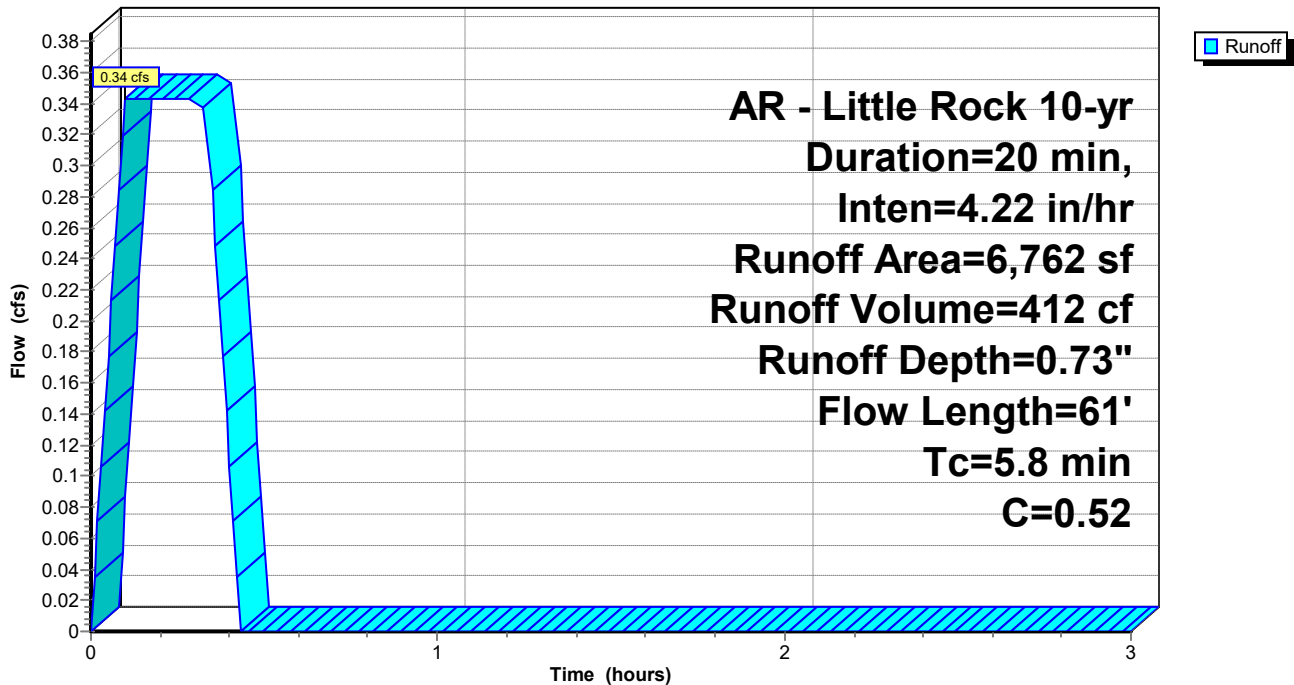

Goddard

Prepared by Phillip Lewis Engineering

HydroCAD® 10.20-5c s/n 12520 © 2023 HydroCAD Software Solutions LLC

AR - Little Rock 10-yr Duration=20 min, Inten=4.22 in/hr

Printed 3/25/2026

Summary for Subcatchment B3: Drainage Basin B3

Runoff = 2.28 cfs @ 0.26 hrs, Volume= 2,730 cf, Depth= 0.98"
 Routed to Link FINAL : APPROX DISCHARGE

Runoff by Rational method, Rise/Fall=1.0/1.0 xTc, Time Span= 0.00-3.00 hrs, dt= 0.01 hrs
 AR - Little Rock 10-yr Duration=20 min, Inten=4.22 in/hr

Area (sf)	C	Description
18,730	0.51	Sod Yard
14,559	0.95	Paving, Sidewalks
33,289	0.70	Weighted Average
18,730		56.26% Pervious Area
14,559		43.74% Impervious Area

Tc (min)	Length (feet)	Slope (ft/ft)	Velocity (ft/sec)	Capacity (cfs)	Description
4.9	47	0.1300	0.16		Sheet Flow, Sheet Flow Grass: Bermuda n= 0.410 P2= 4.19"
6.9	53	0.0730	0.13		Sheet Flow, Sheet Flow Grass: Bermuda n= 0.410 P2= 4.19"
0.0	11	0.0940	4.60		Shallow Concentrated Flow, Concentrated Flow Grassed Waterway Kv= 15.0 fps
0.4	53	0.0120	2.22		Shallow Concentrated Flow, Concentrated Flow Paved Kv= 20.3 fps
0.5	59	0.0100	2.03		Shallow Concentrated Flow, Concentrated Flow Paved Kv= 20.3 fps
0.5	47	0.0070	1.70		Shallow Concentrated Flow, Concentrated Flow Paved Kv= 20.3 fps
0.5	56	0.0070	1.70		Shallow Concentrated Flow, Concentrated Flow Paved Kv= 20.3 fps
0.2	38	0.0160	2.57		Shallow Concentrated Flow, Concentrated Flow Paved Kv= 20.3 fps
0.2	30	0.0190	2.80		Shallow Concentrated Flow, Concentrated Flow Paved Kv= 20.3 fps
1.3	216	0.0190	2.80		Shallow Concentrated Flow, Concentrated Flow Paved Kv= 20.3 fps
15.4	610	Total			

Subcatchment B3: Drainage Basin B3

Hydrograph

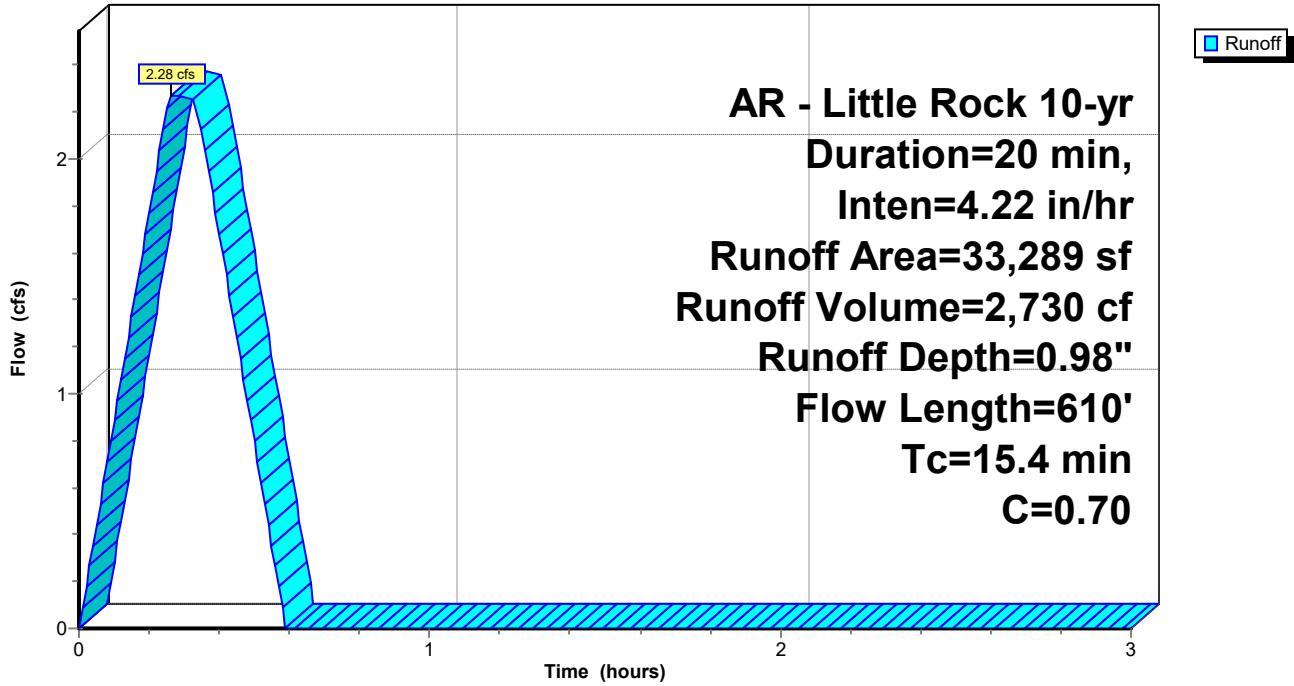

Goddard

Prepared by Phillip Lewis Engineering

HydroCAD® 10.20-5c s/n 12520 © 2023 HydroCAD Software Solutions LLC

AR - Little Rock 10-yr Duration=20 min, Inten=4.22 in/hr

Printed 3/25/2026

Summary for Subcatchment B4: Drainage Basin B4

Runoff = 1.60 cfs @ 0.09 hrs, Volume= 1,918 cf, Depth= 1.18"
 Routed to Pond CI-A1 : CI - A1

Runoff by Rational method, Rise/Fall=1.0/1.0 xTc, Time Span= 0.00-3.00 hrs, dt= 0.01 hrs
 AR - Little Rock 10-yr Duration=20 min, Inten=4.22 in/hr

Area (sf)	C	Description
4,916	0.51	Sod Yard
14,577	0.95	Paving, Sidewalks
19,493	0.84	Weighted Average
4,916		25.22% Pervious Area
14,577		74.78% Impervious Area

Tc (min)	Length (feet)	Slope (ft/ft)	Velocity (ft/sec)	Capacity (cfs)	Description
0.4	31	0.0230	1.32		Sheet Flow, Sheet Flow Smooth surfaces n= 0.011 P2= 4.19"
0.2	18	0.0250	1.22		Sheet Flow, Sheet Flow Smooth surfaces n= 0.011 P2= 4.19"
0.3	28	0.0450	1.69		Sheet Flow, Sheet Flow Smooth surfaces n= 0.011 P2= 4.19"
0.4	72	0.0250	3.21		Shallow Concentrated Flow, Concentrated Flow Paved Kv= 20.3 fps
0.1	18	0.0170	2.65		Shallow Concentrated Flow, Concentrated Flow Paved Kv= 20.3 fps
0.3	51	0.0170	2.65		Shallow Concentrated Flow, Concentrated Flow Paved Kv= 20.3 fps
0.1	16	0.0170	2.65		Shallow Concentrated Flow, Concentrated Flow Paved Kv= 20.3 fps
0.0	8	0.0430	4.21		Shallow Concentrated Flow, Concentrated Flow Paved Kv= 20.3 fps
0.0	7	0.0580	4.89		Shallow Concentrated Flow, Concentrated Flow Paved Kv= 20.3 fps
3.2					Direct Entry, Overland Concentrated Flow (Min)
5.0	249	Total			

Subcatchment B4: Drainage Basin B4

Hydrograph

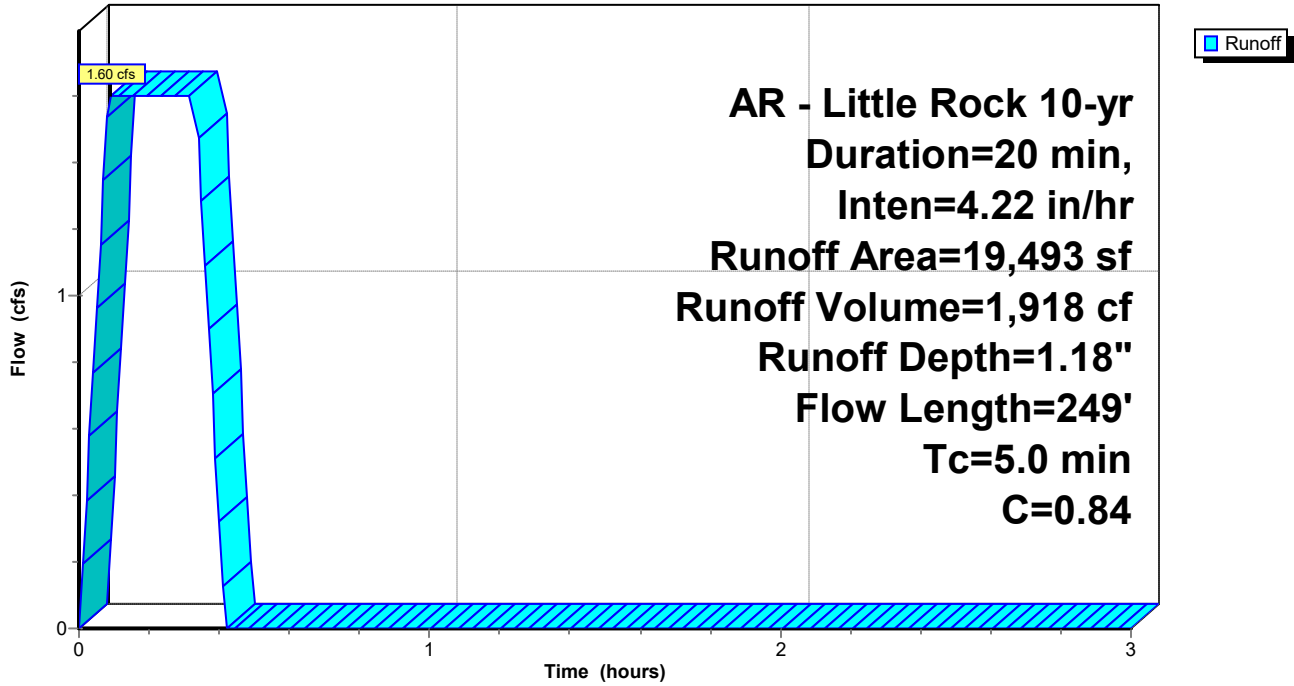

Summary for Subcatchment B5: Drainage Basin B5

Runoff = 0.86 cfs @ 0.09 hrs, Volume= 1,032 cf, Depth= 1.34"
 Routed to Pond JB-A2 : JB - A2

Runoff by Rational method, Rise/Fall=1.0/1.0 xTc, Time Span= 0.00-3.00 hrs, dt= 0.01 hrs
 AR - Little Rock 10-yr Duration=20 min, Inten=4.22 in/hr

Area (sf)	C	Description
9,275	0.95	Roof
9,275		100.00% Impervious Area

Tc (min)	Length (feet)	Slope (ft/ft)	Velocity (ft/sec)	Capacity (cfs)	Description
5.0					Direct Entry, Concentrated Flow (Min)

Subcatchment B5: Drainage Basin B5

Hydrograph

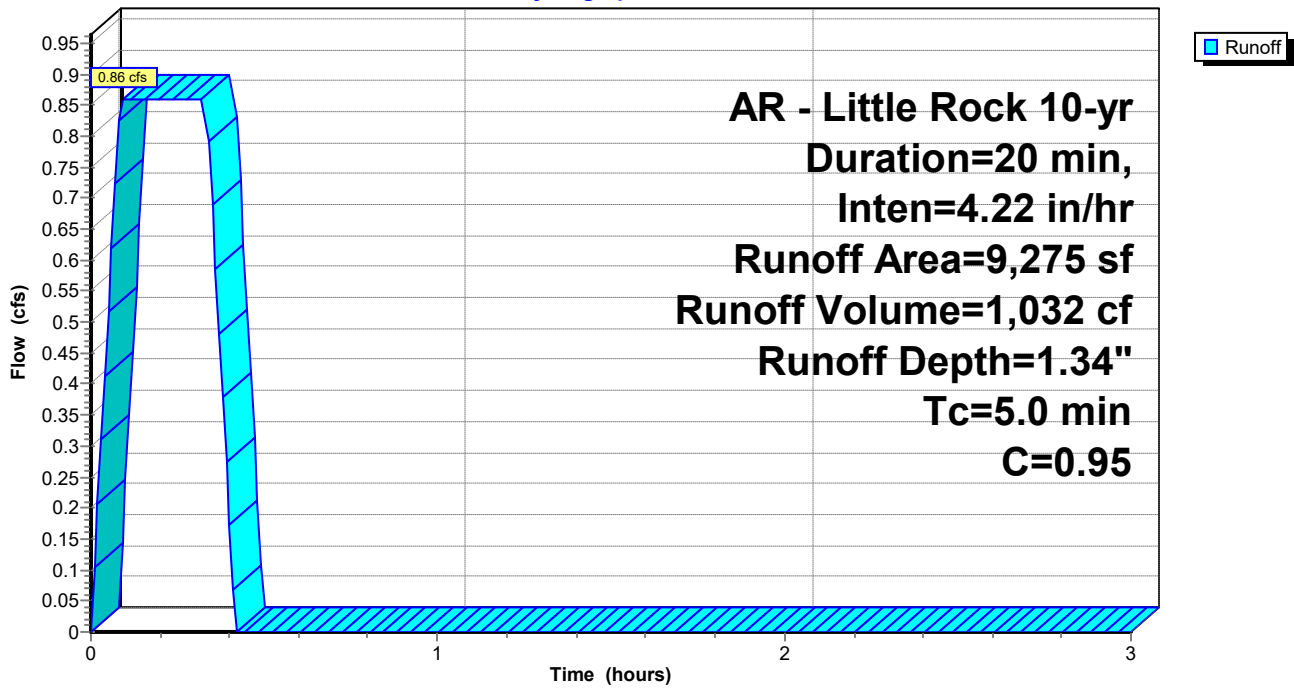

Goddard

Prepared by Phillip Lewis Engineering

HydroCAD® 10.20-5c s/n 12520 © 2023 HydroCAD Software Solutions LLC

AR - Little Rock 10-yr Duration=20 min, Inten=4.22 in/hr

Printed 3/25/2026

Summary for Subcatchment B6: Drainage Basin B6

Runoff = 0.18 cfs @ 0.09 hrs, Volume= 210 cf, Depth= 1.34"
 Routed to Pond CI-A3 : CI - A3

Runoff by Rational method, Rise/Fall=1.0/1.0 xTc, Time Span= 0.00-3.00 hrs, dt= 0.01 hrs
 AR - Little Rock 10-yr Duration=20 min, Inten=4.22 in/hr

Area (sf)	C	Description
0	0.51	Sod Yard
1,887	0.95	Paving, Sidewalks
1,887	0.95	Weighted Average
1,887		100.00% Impervious Area

Tc (min)	Length (feet)	Slope (ft/ft)	Velocity (ft/sec)	Capacity (cfs)	Description
0.4	31	0.0230	1.32		Sheet Flow, Sheet Flow Smooth surfaces n= 0.011 P2= 4.19"
0.2	18	0.0250	1.22		Sheet Flow, Sheet Flow Smooth surfaces n= 0.011 P2= 4.19"
0.4	30	0.0240	1.33		Sheet Flow, Sheet Flow Smooth surfaces n= 0.011 P2= 4.19"
0.0	13	0.0860	5.95		Shallow Concentrated Flow, Concentrated Flow Paved Kv= 20.3 fps
4.0	415		1.73		Direct Entry, Overland Concentrated Flow (Min)
5.0	507	Total			

Subcatchment B6: Drainage Basin B6

Hydrograph

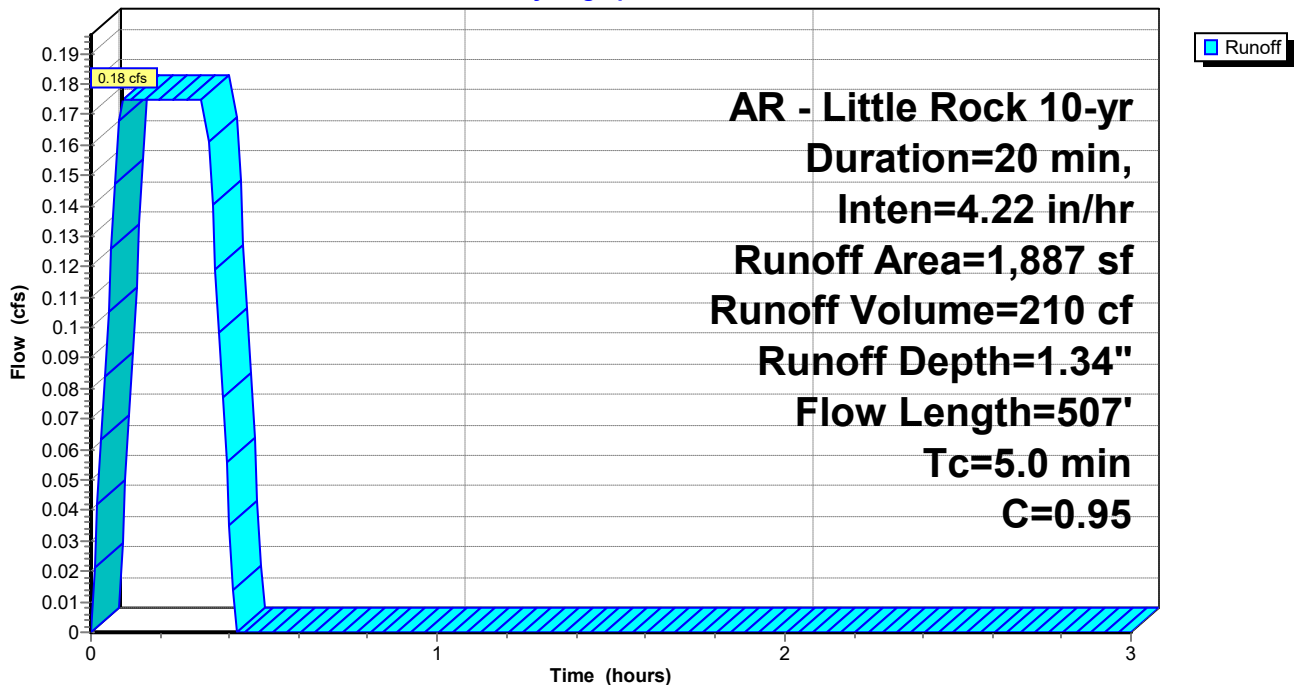

Goddard

Prepared by Phillip Lewis Engineering

HydroCAD® 10.20-5c s/n 12520 © 2023 HydroCAD Software Solutions LLC

AR - Little Rock 10-yr Duration=20 min, Inten=4.22 in/hr

Printed 3/25/2026

Summary for Subcatchment B7: Drainage Basin B7

Runoff = 1.39 cfs @ 0.17 hrs, Volume= 1,662 cf, Depth= 0.90"
 Routed to Pond CI-B2 : CI - B2

Runoff by Rational method, Rise/Fall=1.0/1.0 xTc, Time Span= 0.00-3.00 hrs, dt= 0.01 hrs
 AR - Little Rock 10-yr Duration=20 min, Inten=4.22 in/hr

Area (sf)	C	Description
15,580	0.51	Sod Yard
6,589	0.95	Paving, Sidewalks
22,169	0.64	Weighted Average
15,580		70.28% Pervious Area
6,589		29.72% Impervious Area

Tc (min)	Length (feet)	Slope (ft/ft)	Velocity (ft/sec)	Capacity (cfs)	Description
0.2	10	0.0150	0.89		Sheet Flow, Sheet Flow Smooth surfaces n= 0.011 P2= 4.19"
9.1	93	0.0150	0.17		Sheet Flow, Sheet Flow Grass: Short n= 0.150 P2= 4.19"
0.4	40	0.0110	1.57		Shallow Concentrated Flow, Concentrated Flow Grassed Waterway Kv= 15.0 fps
0.3	33	0.0190	2.07		Shallow Concentrated Flow, Concentrated Flow Grassed Waterway Kv= 15.0 fps
0.0	6	0.0180	2.72		Shallow Concentrated Flow, Concentrated Flow Paved Kv= 20.3 fps
10.0	182	Total			

Subcatchment B7: Drainage Basin B7

Hydrograph

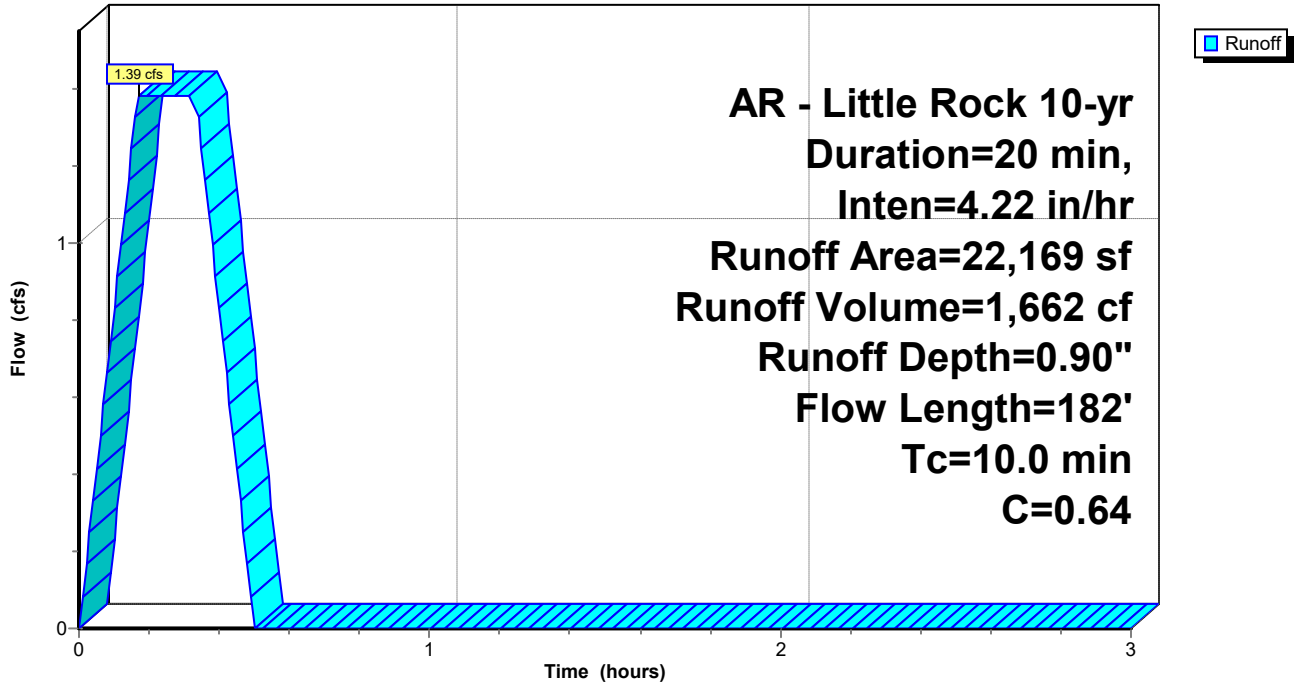

Goddard

Prepared by Phillip Lewis Engineering

HydroCAD® 10.20-5c s/n 12520 © 2023 HydroCAD Software Solutions LLC

AR - Little Rock 10-yr Duration=20 min, Inten=4.22 in/hr

Printed 3/25/2026

Summary for Subcatchment B8: Drainage Basin B8

Runoff = 1.00 cfs @ 0.24 hrs, Volume= 1,201 cf, Depth= 1.00"
 Routed to Pond CI-A4 : CI - A4

Runoff by Rational method, Rise/Fall=1.0/1.0 xTc, Time Span= 0.00-3.00 hrs, dt= 0.01 hrs
 AR - Little Rock 10-yr Duration=20 min, Inten=4.22 in/hr

Area (sf)	C	Description
7,982	0.51	Sod Yard
6,458	0.95	Paving, Sidewalks
14,440	0.71	Weighted Average
7,982		55.28% Pervious Area
6,458		44.72% Impervious Area

Tc (min)	Length (feet)	Slope (ft/ft)	Velocity (ft/sec)	Capacity (cfs)	Description
10.4	79	0.0570	0.13		Sheet Flow, Sheet Flow Grass: Bermuda n= 0.410 P2= 4.19"
3.5	21	0.0620	0.10		Sheet Flow, Sheet Flow Grass: Bermuda n= 0.410 P2= 4.19"
0.0	9	0.0620	3.73		Shallow Concentrated Flow, Concentrated Flow Grassed Waterway Kv= 15.0 fps
0.1	18	0.1080	4.93		Shallow Concentrated Flow, Concentrated Flow Grassed Waterway Kv= 15.0 fps
14.0	127	Total			

Subcatchment B8: Drainage Basin B8

Hydrograph

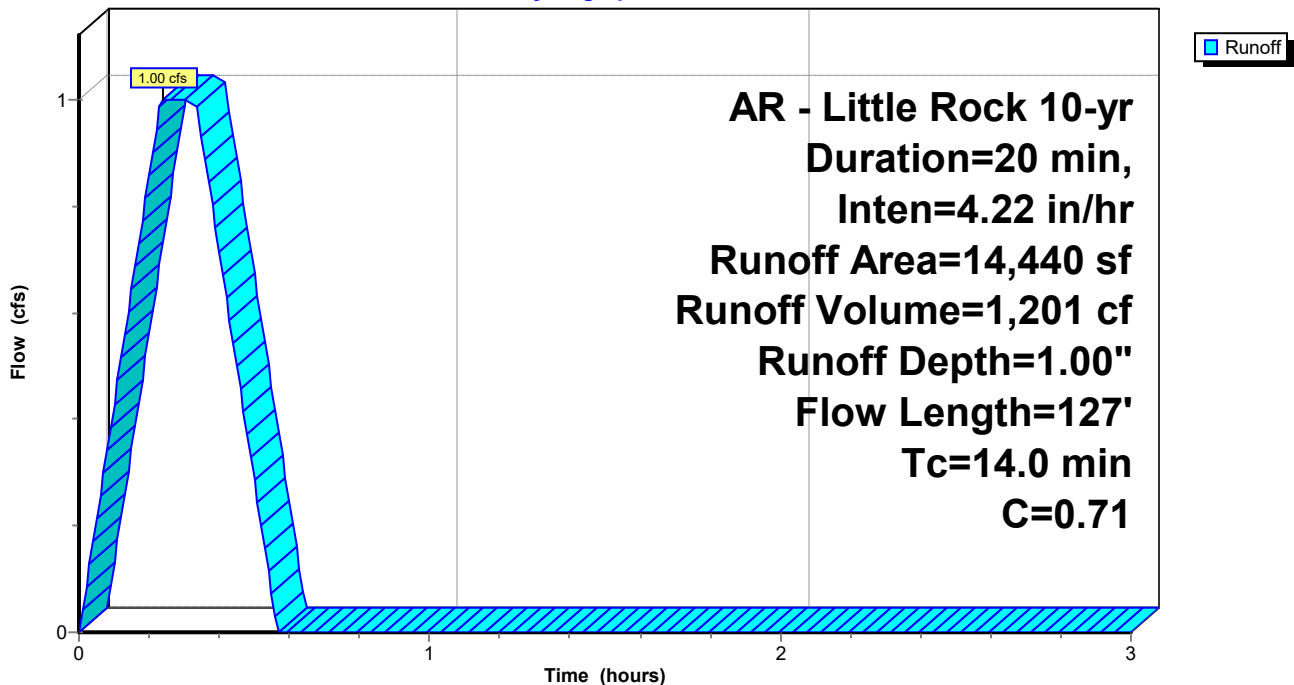

Goddard

Prepared by Phillip Lewis Engineering

HydroCAD® 10.20-5c s/n 12520 © 2023 HydroCAD Software Solutions LLC

AR - Little Rock 10-yr Duration=20 min, Inten=4.22 in/hr

Printed 3/25/2026

Summary for Subcatchment C1: Drainage Basin C1

Runoff = 1.55 cfs @ 0.09 hrs, Volume= 1,858 cf, Depth= 1.10"
 Routed to Pond CI-C1 : CI - C1

Runoff by Rational method, Rise/Fall=1.0/1.0 xTc, Time Span= 0.00-3.00 hrs, dt= 0.01 hrs
 AR - Little Rock 10-yr Duration=20 min, Inten=4.22 in/hr

Area (sf)	C	Description
6,135	0.40	Sod Yard
14,202	0.95	Paving, Sidewalks
20,337	0.78	Weighted Average
6,135		30.17% Pervious Area
14,202		69.83% Impervious Area

Tc (min)	Length (feet)	Slope (ft/ft)	Velocity (ft/sec)	Capacity (cfs)	Description
4.8	32	0.0660	0.11		Sheet Flow, Sheet Flow Grass: Bermuda n= 0.410 P2= 4.19"
0.4	102	0.0470	4.40		Shallow Concentrated Flow, Concentrated Flow Paved Kv= 20.3 fps
5.2	134	Total			

Subcatchment C1: Drainage Basin C1

Hydrograph

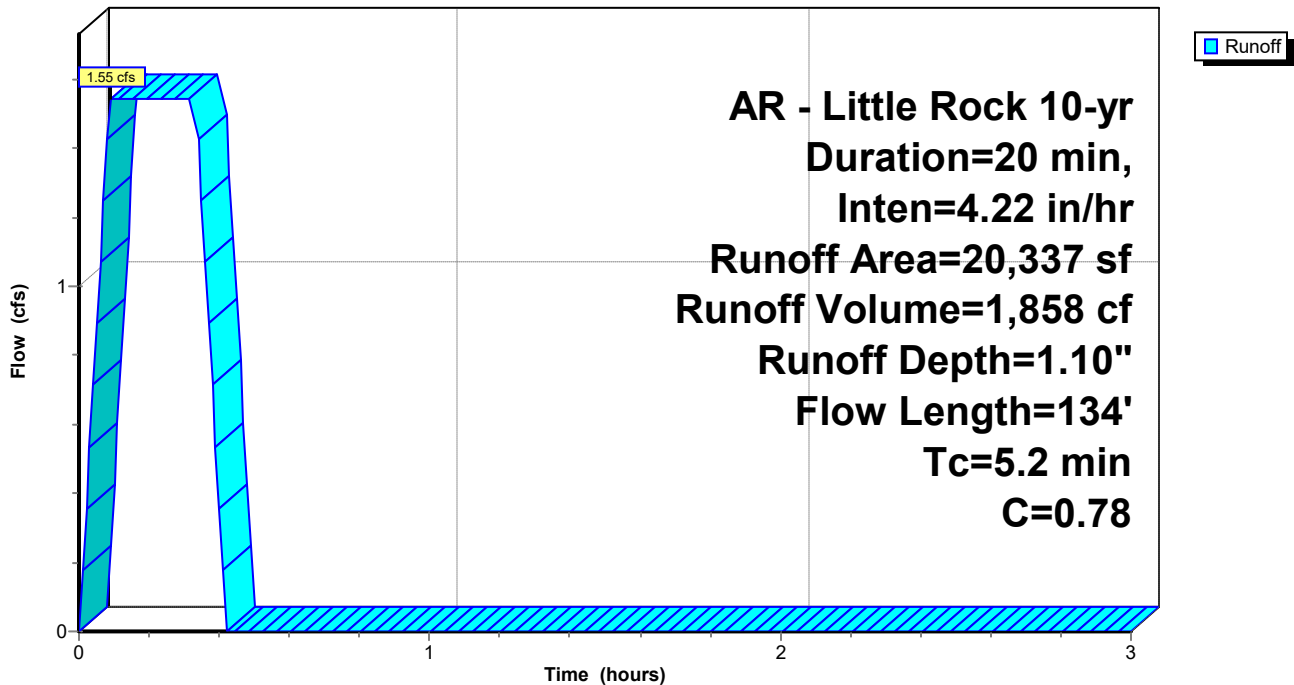

Goddard

Prepared by Phillip Lewis Engineering

HydroCAD® 10.20-5c s/n 12520 © 2023 HydroCAD Software Solutions LLC

AR - Little Rock 10-yr Duration=20 min, Inten=4.22 in/hr

Printed 3/25/2026

Summary for Subcatchment C10: Drainage Basin C10

Runoff = 0.44 cfs @ 0.09 hrs, Volume= 526 cf, Depth= 1.17"
 Routed to Pond CI-E1 : CI - E1

Runoff by Rational method, Rise/Fall=1.0/1.0 xTc, Time Span= 0.00-3.00 hrs, dt= 0.01 hrs
 AR - Little Rock 10-yr Duration=20 min, Inten=4.22 in/hr

Area (sf)	C	Description
1,225	0.40	Sod Yard
4,183	0.95	Paving, Sidewalks
5,408	0.83	Weighted Average
1,225		22.65% Pervious Area
4,183		77.35% Impervious Area

Tc (min)	Length (feet)	Slope (ft/ft)	Velocity (ft/sec)	Capacity (cfs)	Description
0.3	18	0.0200	1.12		Sheet Flow, Sheet Flow Smooth surfaces n= 0.011 P2= 4.19"
0.2	29	0.0210	2.94		Shallow Concentrated Flow, Concentrated Flow Paved Kv= 20.3 fps
0.1	23	0.0320	3.63		Shallow Concentrated Flow, Concentrated Flow Paved Kv= 20.3 fps
0.2	36	0.0320	3.63		Shallow Concentrated Flow, Concentrated Flow Paved Kv= 20.3 fps
0.2	48	0.0330	3.69		Shallow Concentrated Flow, Concentrated Flow Paved Kv= 20.3 fps
0.1	13	0.0350	3.80		Shallow Concentrated Flow, Concentrated Flow Paved Kv= 20.3 fps
3.9	415		1.77		Direct Entry, Concentrated Flow (Min)
5.0	582	Total			

Subcatchment C10: Drainage Basin C10

Hydrograph

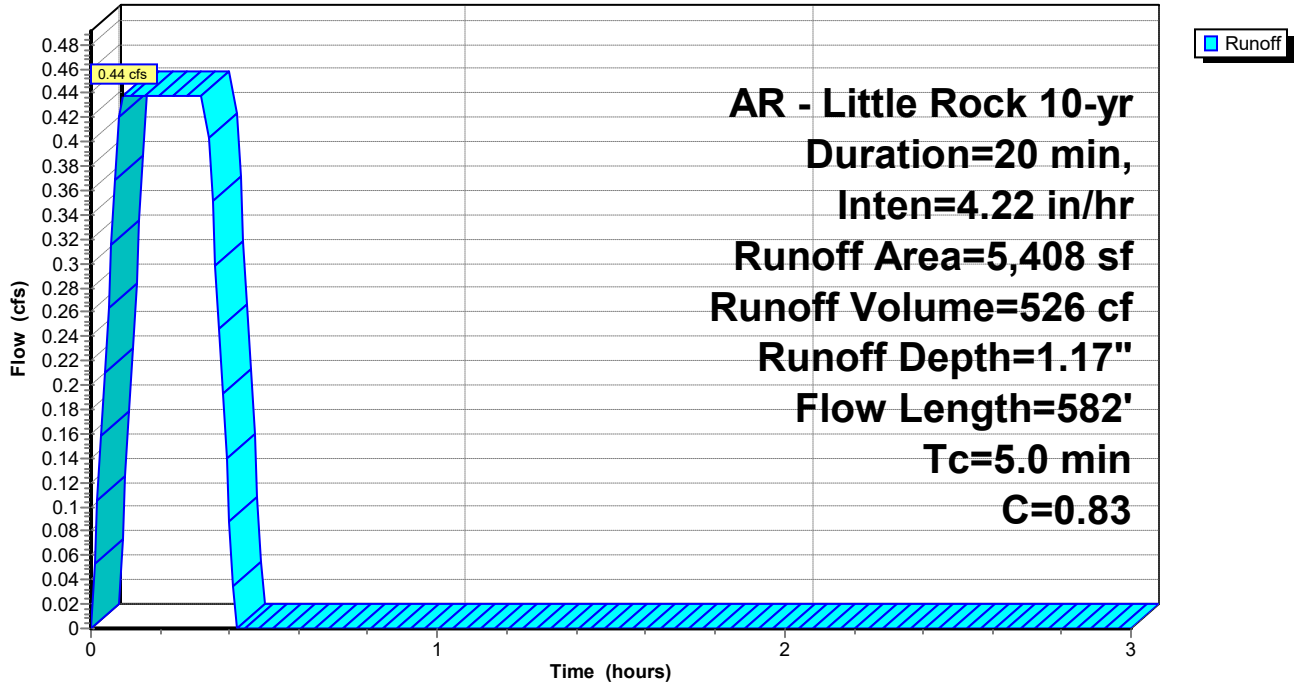

Goddard

Prepared by Phillip Lewis Engineering

HydroCAD® 10.20-5c s/n 12520 © 2023 HydroCAD Software Solutions LLC

AR - Little Rock 10-yr Duration=20 min, Inten=4.22 in/hr

Printed 3/25/2026

Summary for Subcatchment C11: Drainage Basin C11

Runoff = 0.42 cfs @ 0.09 hrs, Volume= 500 cf, Depth= 0.97"
 Routed to Pond CI-E2 : CI - E2

Runoff by Rational method, Rise/Fall=1.0/1.0 xTc, Time Span= 0.00-3.00 hrs, dt= 0.01 hrs
 AR - Little Rock 10-yr Duration=20 min, Inten=4.22 in/hr

Area (sf)	C	Description
2,876	0.40	Sod Yard
3,307	0.95	Paving, Sidewalks
6,183	0.69	Weighted Average
2,876		46.51% Pervious Area
3,307		53.49% Impervious Area

Tc (min)	Length (feet)	Slope (ft/ft)	Velocity (ft/sec)	Capacity (cfs)	Description
0.3	25	0.0200	1.19		Sheet Flow, Sheet Flow Smooth surfaces n= 0.011 P2= 4.19"
0.1	33	0.0620	5.05		Shallow Concentrated Flow, Concentrated Flow Paved Kv= 20.3 fps
0.1	29	0.0540	4.72		Shallow Concentrated Flow, Concentrated Flow Paved Kv= 20.3 fps
0.2	47	0.0410	4.11		Shallow Concentrated Flow, Concentrated Flow Paved Kv= 20.3 fps
0.2	47	0.0390	4.01		Shallow Concentrated Flow, Concentrated Flow Paved Kv= 20.3 fps
0.1	37	0.0420	4.16		Shallow Concentrated Flow, Concentrated Flow Paved Kv= 20.3 fps
4.0	415		1.73		Direct Entry, Concentrated Flow (Min)
5.0	633	Total			

Subcatchment C11: Drainage Basin C11

Hydrograph

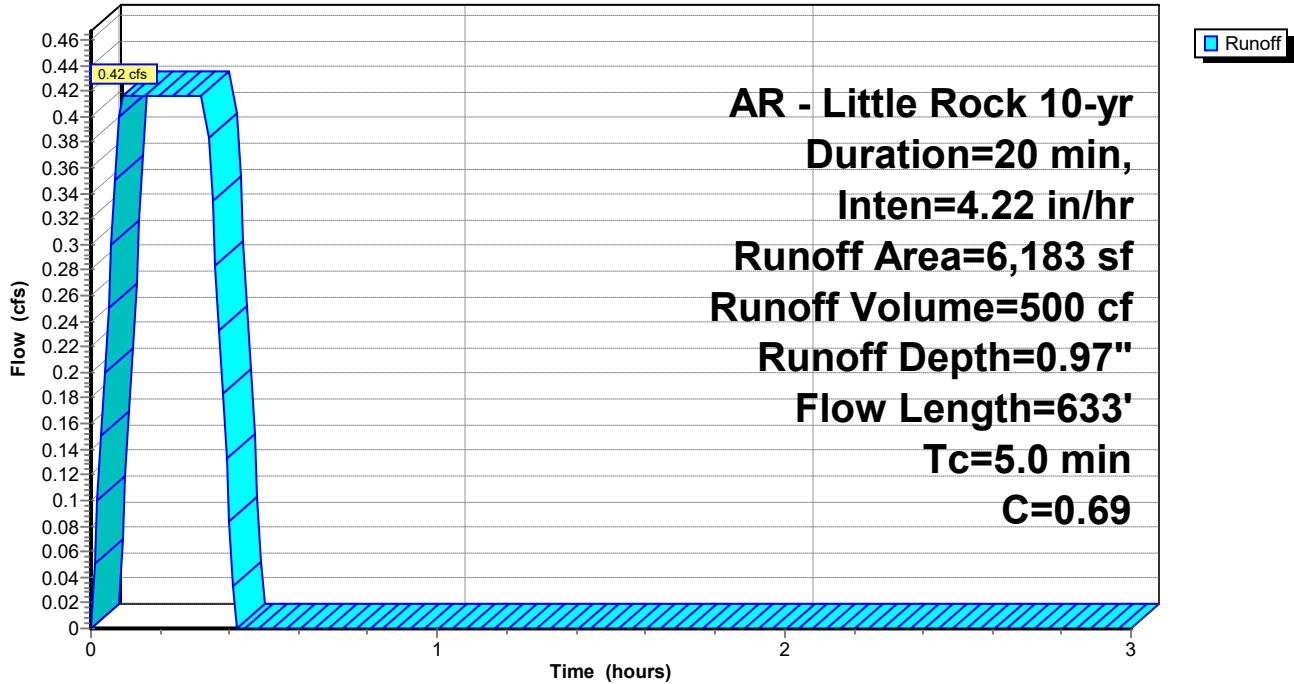

Goddard

Prepared by Phillip Lewis Engineering

HydroCAD® 10.20-5c s/n 12520 © 2023 HydroCAD Software Solutions LLC

AR - Little Rock 10-yr Duration=20 min, Inten=4.22 in/hr

Printed 3/25/2026

Summary for Subcatchment C12: Drainage Basin C12

Runoff = 2.00 cfs @ 0.09 hrs, Volume= 2,405 cf, Depth= 1.12"
 Routed to Pond CI-C7 : CI - C7

Runoff by Rational method, Rise/Fall=1.0/1.0 xTc, Time Span= 0.00-3.00 hrs, dt= 0.01 hrs
 AR - Little Rock 10-yr Duration=20 min, Inten=4.22 in/hr

Area (sf)	C	Description
7,218	0.40	Sod Yard
18,440	0.95	Paving, Sidewalks
25,658	0.80	Weighted Average
7,218		28.13% Pervious Area
18,440		71.87% Impervious Area

Tc (min)	Length (feet)	Slope (ft/ft)	Velocity (ft/sec)	Capacity (cfs)	Description
0.3	24	0.0360	1.50		Sheet Flow, Sheet Flow Smooth surfaces n= 0.011 P2= 4.19"
0.1	5	0.0190	0.85		Sheet Flow, Sheet Flow Smooth surfaces n= 0.011 P2= 4.19"
0.2	21	0.0100	2.03		Shallow Concentrated Flow, Concentrated Flow Paved Kv= 20.3 fps
0.9	49	0.0020	0.91		Shallow Concentrated Flow, Concentrated Flow Paved Kv= 20.3 fps
0.4	96	0.0330	3.69		Shallow Concentrated Flow, Concentrated Flow Paved Kv= 20.3 fps
0.3	94	0.0570	4.85		Shallow Concentrated Flow, Concentrated Flow Paved Kv= 20.3 fps
0.1	28	0.0560	4.80		Shallow Concentrated Flow, Concentrated Flow Paved Kv= 20.3 fps
0.1	25	0.0450	4.31		Shallow Concentrated Flow, Concentrated Flow Paved Kv= 20.3 fps
0.1	31	0.0410	4.11		Shallow Concentrated Flow, Concentrated Flow Paved Kv= 20.3 fps
0.1	39	0.0490	4.49		Shallow Concentrated Flow, Concentrated Flow Paved Kv= 20.3 fps
0.1	36	0.0460	4.35		Shallow Concentrated Flow, Concentrated Flow Paved Kv= 20.3 fps
0.0	11	0.0470	4.40		Shallow Concentrated Flow, Concentrated Flow Paved Kv= 20.3 fps
0.0	6	0.0440	4.26		Shallow Concentrated Flow, Concentrated Flow Paved Kv= 20.3 fps
2.3	415		3.01		Direct Entry, Concentrated Flow (Min)
5.0	880	Total			

Subcatchment C12: Drainage Basin C12

Hydrograph

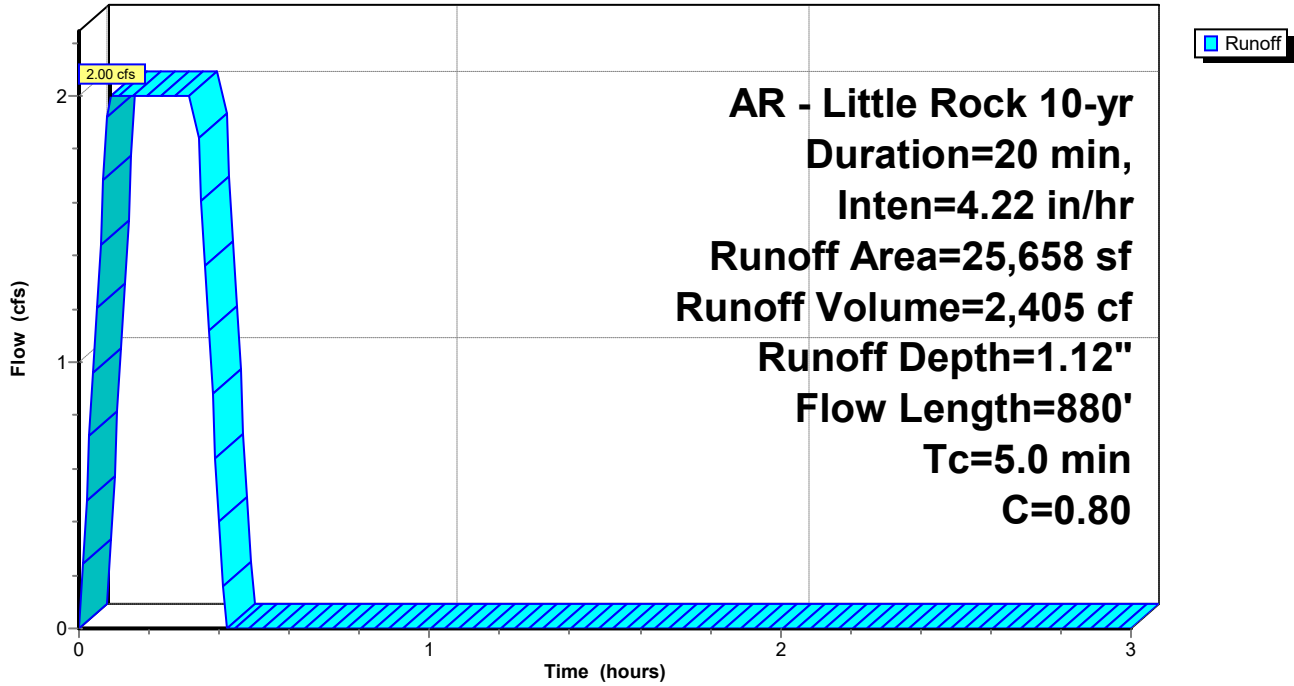

Goddard

Prepared by Phillip Lewis Engineering

HydroCAD® 10.20-5c s/n 12520 © 2023 HydroCAD Software Solutions LLC

AR - Little Rock 10-yr Duration=20 min, Inten=4.22 in/hr

Printed 3/25/2026

Summary for Subcatchment C13: Drainage Basin C13

Runoff = 0.65 cfs @ 0.09 hrs, Volume= 782 cf, Depth= 1.18"
 Routed to Pond CI-A4 : CI - A4

Runoff by Rational method, Rise/Fall=1.0/1.0 xTc, Time Span= 0.00-3.00 hrs, dt= 0.01 hrs
 AR - Little Rock 10-yr Duration=20 min, Inten=4.22 in/hr

Area (sf)	C	Description
1,558	0.40	Sod Yard
6,388	0.95	Paving, Sidewalks
7,946	0.84	Weighted Average
1,558		19.61% Pervious Area
6,388		80.39% Impervious Area

Tc (min)	Length (feet)	Slope (ft/ft)	Velocity (ft/sec)	Capacity (cfs)	Description
0.3	19	0.0200	1.13		Sheet Flow, Sheet Flow Smooth surfaces n= 0.011 P2= 4.19"
0.3	75	0.0340	3.74		Shallow Concentrated Flow, Concentrated Flow Paved Kv= 20.3 fps
0.2	52	0.0410	4.11		Shallow Concentrated Flow, Concentrated Flow Paved Kv= 20.3 fps
0.1	29	0.0470	4.40		Shallow Concentrated Flow, Concentrated Flow Paved Kv= 20.3 fps
0.1	42	0.0730	5.48		Shallow Concentrated Flow, Concentrated Flow Paved Kv= 20.3 fps
0.2	74	0.0750	5.56		Shallow Concentrated Flow, Concentrated Flow Paved Kv= 20.3 fps
0.1	26	0.0710	5.41		Shallow Concentrated Flow, Concentrated Flow Paved Kv= 20.3 fps
0.1	32	0.0570	4.85		Shallow Concentrated Flow, Concentrated Flow Paved Kv= 20.3 fps
0.0	13	0.0470	4.40		Shallow Concentrated Flow, Concentrated Flow Paved Kv= 20.3 fps
3.6	415		1.92		Direct Entry, Overland Concentrated Flow (Min)
5.0	777	Total			

Subcatchment C13: Drainage Basin C13

Hydrograph

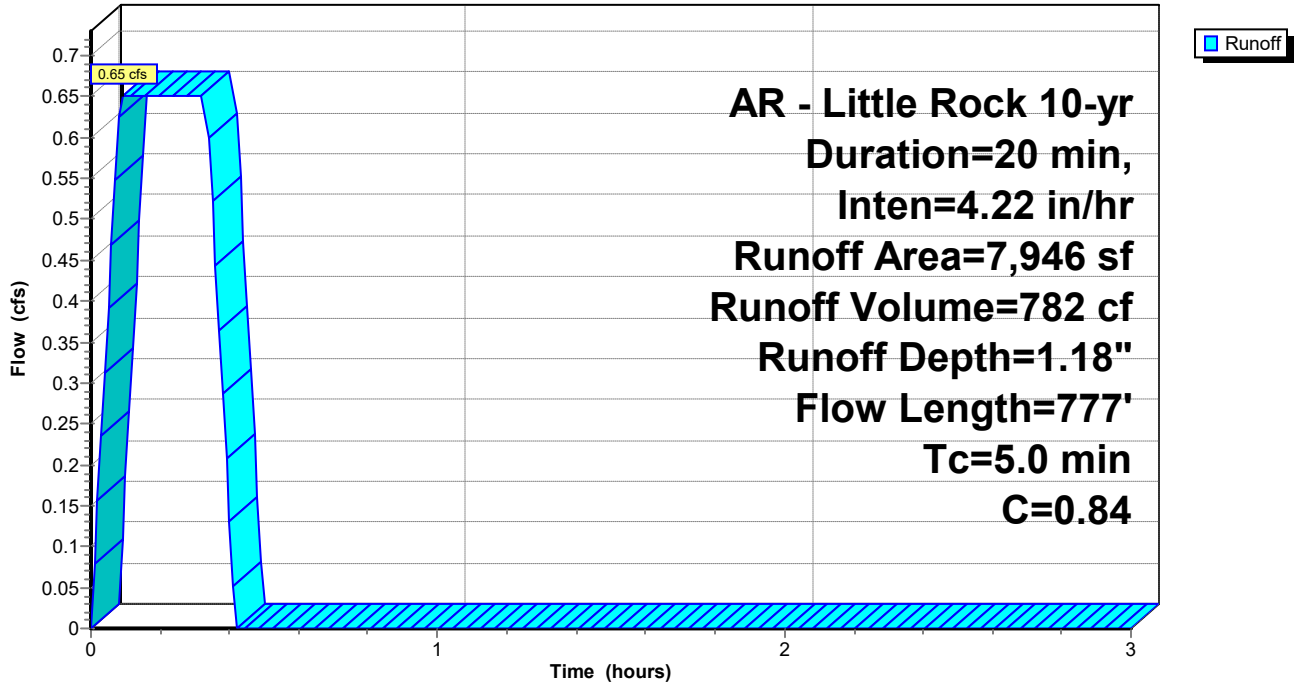

Goddard

Prepared by Phillip Lewis Engineering

HydroCAD® 10.20-5c s/n 12520 © 2023 HydroCAD Software Solutions LLC

AR - Little Rock 10-yr Duration=20 min, Inten=4.22 in/hr

Printed 3/25/2026

Summary for Subcatchment C14: Drainage Basin C14

Runoff = 1.72 cfs @ 0.27 hrs, Volume= 2,065 cf, Depth= 1.12"
 Routed to Pond CI-A5 : CI - A5

Runoff by Rational method, Rise/Fall=1.0/1.0 xTc, Time Span= 0.00-3.00 hrs, dt= 0.01 hrs
 AR - Little Rock 10-yr Duration=20 min, Inten=4.22 in/hr

Area (sf)	C	Description
6,127	0.40	Sod Yard
15,898	0.95	Paving, Sidewalks
22,025	0.80	Weighted Average
6,127		27.82% Pervious Area
15,898		72.18% Impervious Area

Tc (min)	Length (feet)	Slope (ft/ft)	Velocity (ft/sec)	Capacity (cfs)	Description
1.5	5	0.0310	0.06		Sheet Flow, Sheet Flow
					Grass: Bermuda n= 0.410 P2= 4.19"
9.2	45	0.0250	0.08		Sheet Flow, Sheet Flow
					Grass: Bermuda n= 0.410 P2= 4.19"
3.8	41	0.1940	0.18		Sheet Flow, Sheet Flow
					Grass: Bermuda n= 0.410 P2= 4.19"
0.1	6	0.0100	0.68		Sheet Flow, Sheet Flow
					Smooth surfaces n= 0.011 P2= 4.19"
0.1	51	0.0870	5.99		Shallow Concentrated Flow, Concentrated Flow
					Paved Kv= 20.3 fps
0.2	52	0.0310	3.57		Shallow Concentrated Flow, Concentrated Flow
					Paved Kv= 20.3 fps
0.1	18	0.0270	3.34		Shallow Concentrated Flow, Concentrated Flow
					Paved Kv= 20.3 fps
0.1	20	0.0400	4.06		Shallow Concentrated Flow, Concentrated Flow
					Paved Kv= 20.3 fps
0.1	34	0.0410	4.11		Shallow Concentrated Flow, Concentrated Flow
					Paved Kv= 20.3 fps
0.2	46	0.0470	4.40		Shallow Concentrated Flow, Concentrated Flow
					Paved Kv= 20.3 fps
0.1	36	0.0580	4.89		Shallow Concentrated Flow, Concentrated Flow
					Paved Kv= 20.3 fps
0.2	58	0.0690	5.33		Shallow Concentrated Flow, Concentrated Flow
					Paved Kv= 20.3 fps
0.1	49	0.0840	5.88		Shallow Concentrated Flow, Concentrated Flow
					Paved Kv= 20.3 fps
0.1	31	0.0690	5.33		Shallow Concentrated Flow, Concentrated Flow
					Paved Kv= 20.3 fps
15.9	492	Total			

Subcatchment C14: Drainage Basin C14

Hydrograph

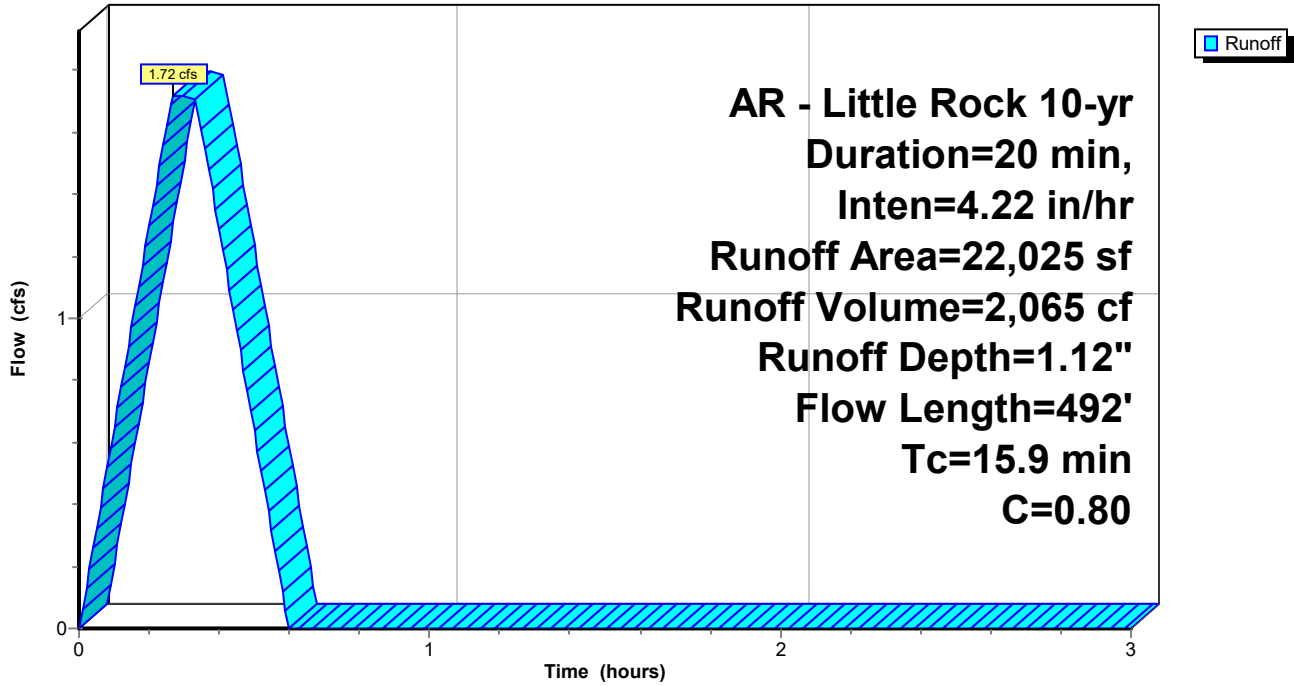

Summary for Subcatchment C15: Drainage Basin C15

Runoff = 1.25 cfs @ 0.09 hrs, Volume= 1,497 cf, Depth= 1.34"

Routed to Pond DP : Existing North Detention Pond

Runoff by Rational method, Rise/Fall=1.0/1.0 xTc, Time Span= 0.00-3.00 hrs, dt= 0.01 hrs

AR - Little Rock 10-yr Duration=20 min, Inten=4.22 in/hr

Area (sf)	C	Description
0	0.40	Sod Yard
13,450	0.95	Paving, Sidewalks
13,450	0.95	Weighted Average
13,450		100.00% Impervious Area

Tc (min)	Length (feet)	Slope (ft/ft)	Velocity (ft/sec)	Capacity (cfs)	Description
5.0	415		1.38		Direct Entry, Overland Concentrated Flow (Min)

Subcatchment C15: Drainage Basin C15

Hydrograph

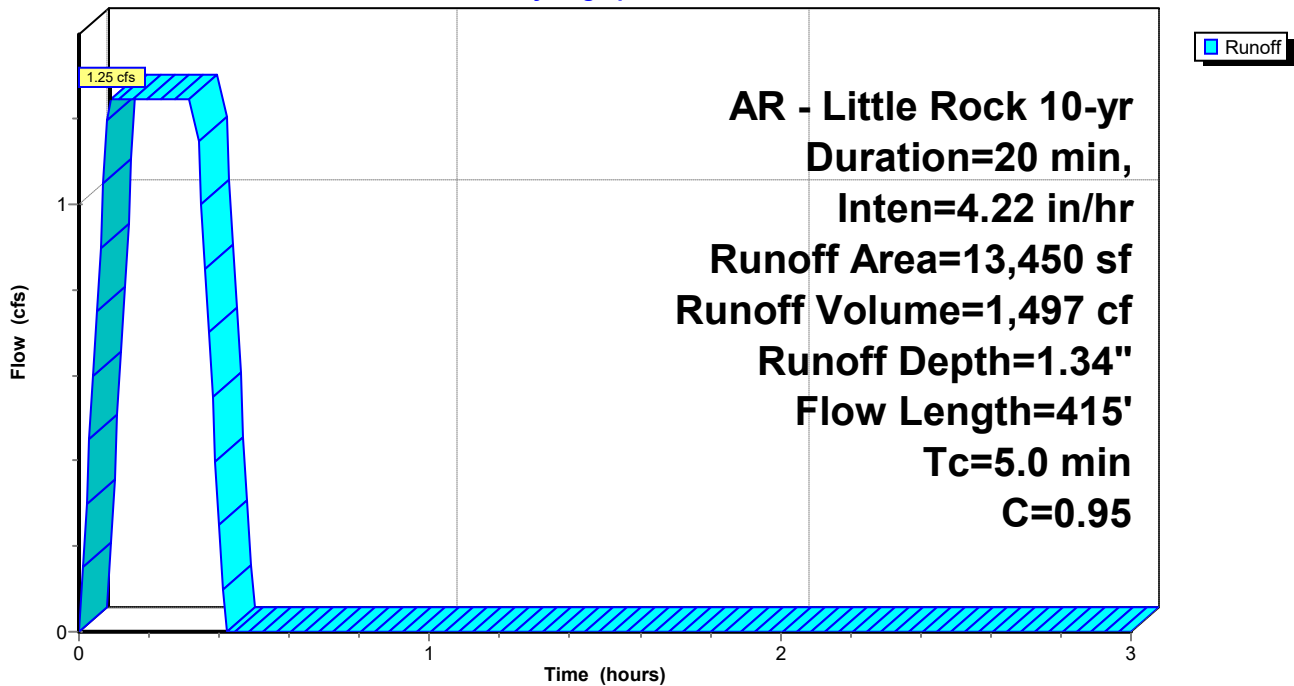

Goddard

Prepared by Phillip Lewis Engineering

HydroCAD® 10.20-5c s/n 12520 © 2023 HydroCAD Software Solutions LLC

AR - Little Rock 10-yr Duration=20 min, Inten=4.22 in/hr

Printed 3/25/2026

Summary for Subcatchment C16: Drainage Basin C16

Runoff = 1.21 cfs @ 0.09 hrs, Volume= 1,448 cf, Depth= 0.79"

Routed to Pond DP : Existing North Detention Pond

Runoff by Rational method, Rise/Fall=1.0/1.0 xTc, Time Span= 0.00-3.00 hrs, dt= 0.01 hrs

AR - Little Rock 10-yr Duration=20 min, Inten=4.22 in/hr

Area (sf)	C	Description
15,465	0.40	Sod Yard
6,612	0.95	Paving, Sidewalks
22,077	0.56	Weighted Average
15,465		70.05% Pervious Area
6,612		29.95% Impervious Area

Tc (min)	Length (feet)	Slope (ft/ft)	Velocity (ft/sec)	Capacity (cfs)	Description
0.4	26	0.0190	1.18		Sheet Flow, Sheet Flow
					Smooth surfaces n= 0.011 P2= 4.19"
0.1	5	0.0100	0.66		Sheet Flow, Sheet Flow
					Smooth surfaces n= 0.011 P2= 4.19"
0.4	51	0.0500	1.98		Sheet Flow, Sheet Flow
					Smooth surfaces n= 0.011 P2= 4.19"
0.1	12	0.1540	2.33		Sheet Flow, Sheet Flow
					Smooth surfaces n= 0.011 P2= 4.19"
0.1	50	0.1330	7.40		Shallow Concentrated Flow, Concentrated Flow
					Paved Kv= 20.3 fps
0.1	50	0.1170	6.94		Shallow Concentrated Flow, Concentrated Flow
					Paved Kv= 20.3 fps
0.2	46	0.0430	4.21		Shallow Concentrated Flow, Concentrated Flow
					Paved Kv= 20.3 fps
0.3	59	0.0370	3.90		Shallow Concentrated Flow, Concentrated Flow
					Paved Kv= 20.3 fps
3.3	415		2.10		Direct Entry, Overland Concentrated Flow (Min)
5.0	714	Total			

Subcatchment C16: Drainage Basin C16

Hydrograph

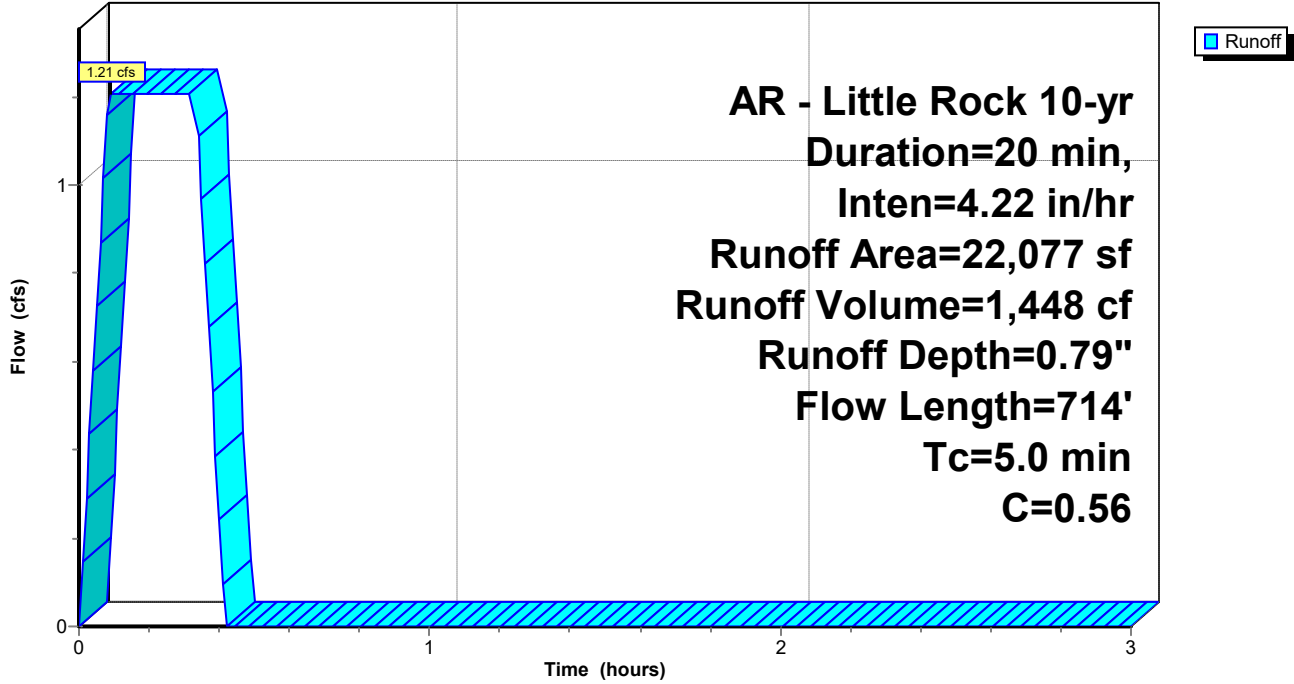

Goddard

Prepared by Phillip Lewis Engineering

HydroCAD® 10.20-5c s/n 12520 © 2023 HydroCAD Software Solutions LLC

AR - Little Rock 10-yr Duration=20 min, Inten=4.22 in/hr

Printed 3/25/2026

Summary for Subcatchment C17: Drainage Basin C17

Runoff = 2.22 cfs @ 0.16 hrs, Volume= 2,660 cf, Depth= 0.56"

Routed to Pond DP : Existing North Detention Pond

Runoff by Rational method, Rise/Fall=1.0/1.0 xTc, Time Span= 0.00-3.00 hrs, dt= 0.01 hrs

AR - Little Rock 10-yr Duration=20 min, Inten=4.22 in/hr

Area (sf)	C	Description
56,749	0.40	Sod Yard
0	0.95	Paving, Sidewalks
56,749	0.40	Weighted Average
56,749		100.00% Pervious Area

Tc (min)	Length (feet)	Slope (ft/ft)	Velocity (ft/sec)	Capacity (cfs)	Description
4.8	43	0.0410	0.15		Sheet Flow, Sheet Flow Grass: Dense n= 0.240 P2= 4.19"
3.9	43	0.0690	0.19		Sheet Flow, Sheet Flow Grass: Dense n= 0.240 P2= 4.19"
0.1	41	0.0980	4.70		Shallow Concentrated Flow, Concentrated Flow Grassed Waterway Kv= 15.0 fps
0.3	61	0.0730	4.05		Shallow Concentrated Flow, Concentrated Flow Grassed Waterway Kv= 15.0 fps
0.2	46	0.0570	3.58		Shallow Concentrated Flow, Concentrated Flow Grassed Waterway Kv= 15.0 fps
0.3	64	0.0450	3.18		Shallow Concentrated Flow, Concentrated Flow Grassed Waterway Kv= 15.0 fps
9.6	298	Total			

Subcatchment C17: Drainage Basin C17

Hydrograph

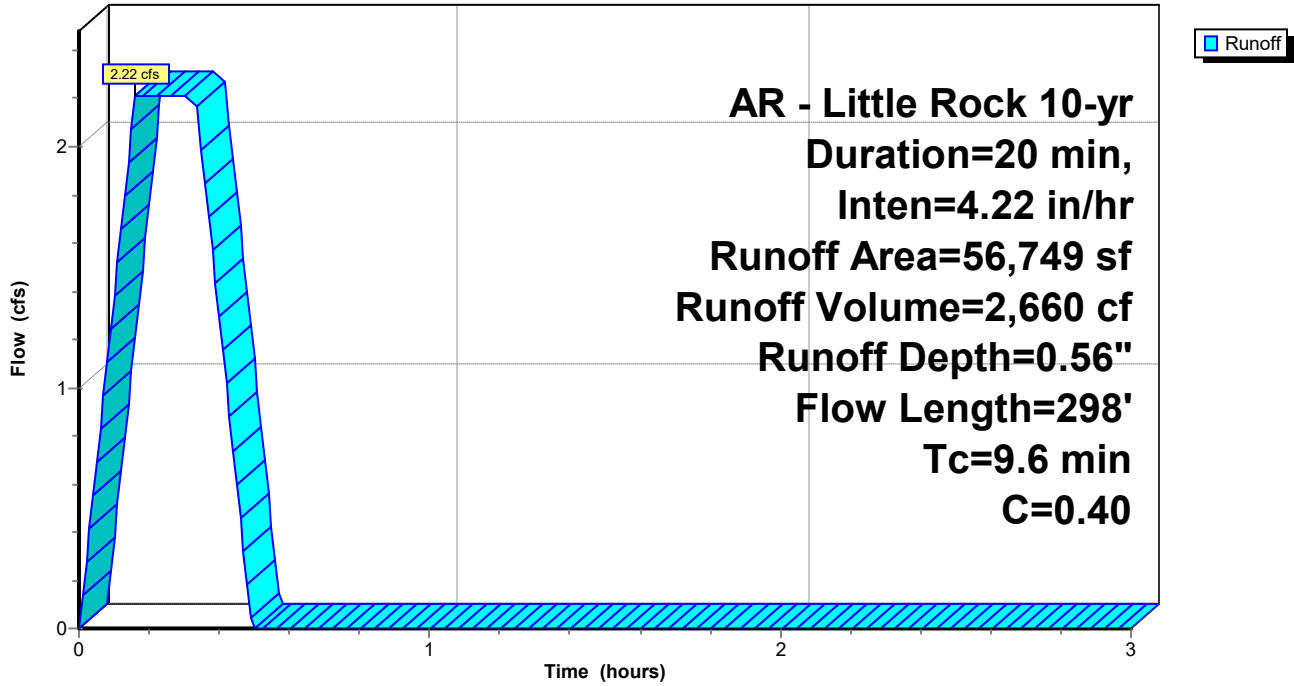

Goddard

Prepared by Phillip Lewis Engineering

HydroCAD® 10.20-5c s/n 12520 © 2023 HydroCAD Software Solutions LLC

AR - Little Rock 10-yr Duration=20 min, Inten=4.22 in/hr

Printed 3/25/2026

Summary for Subcatchment C18: Drainage Basin C18

Runoff = 1.42 cfs @ 0.09 hrs, Volume= 1,708 cf, Depth= 0.90"

Routed to Link FINAL : APPROX DISCHARGE

Runoff by Rational method, Rise/Fall=1.0/1.0 xTc, Time Span= 0.00-3.00 hrs, dt= 0.01 hrs

AR - Little Rock 10-yr Duration=20 min, Inten=4.22 in/hr

Area (sf)	C	Description
12,812	0.40	Sod Yard
9,973	0.95	Paving, Sidewalks
22,785	0.64	Weighted Average
12,812		56.23% Pervious Area
9,973		43.77% Impervious Area

Tc (min)	Length (feet)	Slope (ft/ft)	Velocity (ft/sec)	Capacity (cfs)	Description
0.6	5	0.2980	0.14		Sheet Flow, Sheet Flow Grass: Bermuda n= 0.410 P2= 4.19"
0.2	12	0.0130	0.87		Sheet Flow, Sheet Flow Smooth surfaces n= 0.011 P2= 4.19"
3.3	8	0.0100	0.04		Sheet Flow, Sheet Flow Grass: Bermuda n= 0.410 P2= 4.19"
0.5	80	0.0210	2.94		Shallow Concentrated Flow, Concentrated Flow Paved Kv= 20.3 fps
0.4	415		17.29		Direct Entry, Concentrated Flow (Min)
5.0	520	Total			

Subcatchment C18: Drainage Basin C18

Hydrograph

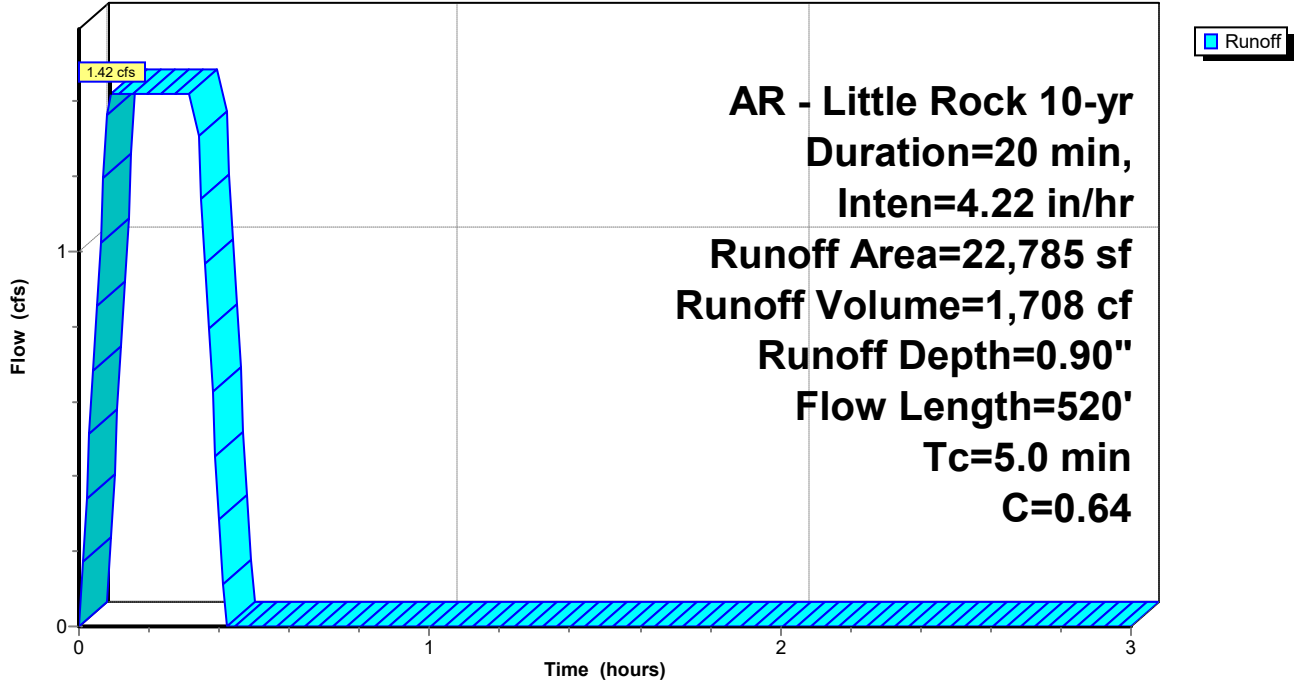

Goddard

Prepared by Phillip Lewis Engineering

HydroCAD® 10.20-5c s/n 12520 © 2023 HydroCAD Software Solutions LLC

AR - Little Rock 10-yr Duration=20 min, Inten=4.22 in/hr

Printed 3/25/2026

Summary for Subcatchment C19: Drainage Basin C19

Runoff = 0.70 cfs @ 0.12 hrs, Volume= 844 cf, Depth= 0.56"

Routed to Link FINAL : APPROX DISCHARGE

Runoff by Rational method, Rise/Fall=1.0/1.0 xTc, Time Span= 0.00-3.00 hrs, dt= 0.01 hrs

AR - Little Rock 10-yr Duration=20 min, Inten=4.22 in/hr

Area (sf)	C	Description
18,009	0.40	Sod Yard
0	0.95	Paving, Sidewalks
18,009	0.40	Weighted Average
18,009		100.00% Pervious Area

Tc (min)	Length (feet)	Slope (ft/ft)	Velocity (ft/sec)	Capacity (cfs)	Description
2.7	34	0.1110	0.21		Sheet Flow, Sheet Flow
					Grass: Dense n= 0.240 P2= 4.19"
3.3	66	0.2450	0.34		Sheet Flow, Sheet Flow
					Grass: Dense n= 0.240 P2= 4.19"
0.0	9	0.2450	7.42		Shallow Concentrated Flow, Concentrated Flow
					Grassed Waterway Kv= 15.0 fps
0.5	106	0.0610	3.70		Shallow Concentrated Flow, Concentrated Flow
					Grassed Waterway Kv= 15.0 fps
0.2	46	0.0800	4.24		Shallow Concentrated Flow, Concentrated Flow
					Grassed Waterway Kv= 15.0 fps
0.1	41	0.0960	4.65		Shallow Concentrated Flow, Concentrated Flow
					Grassed Waterway Kv= 15.0 fps
0.3	66	0.0680	3.91		Shallow Concentrated Flow, Concentrated Flow
					Grassed Waterway Kv= 15.0 fps
0.1	19	0.1070	4.91		Shallow Concentrated Flow, Concentrated Flow
					Grassed Waterway Kv= 15.0 fps
0.0	6	0.0750	4.11		Shallow Concentrated Flow, Concentrated Flow
					Grassed Waterway Kv= 15.0 fps
7.2	393	Total			

Subcatchment C19: Drainage Basin C19

Hydrograph

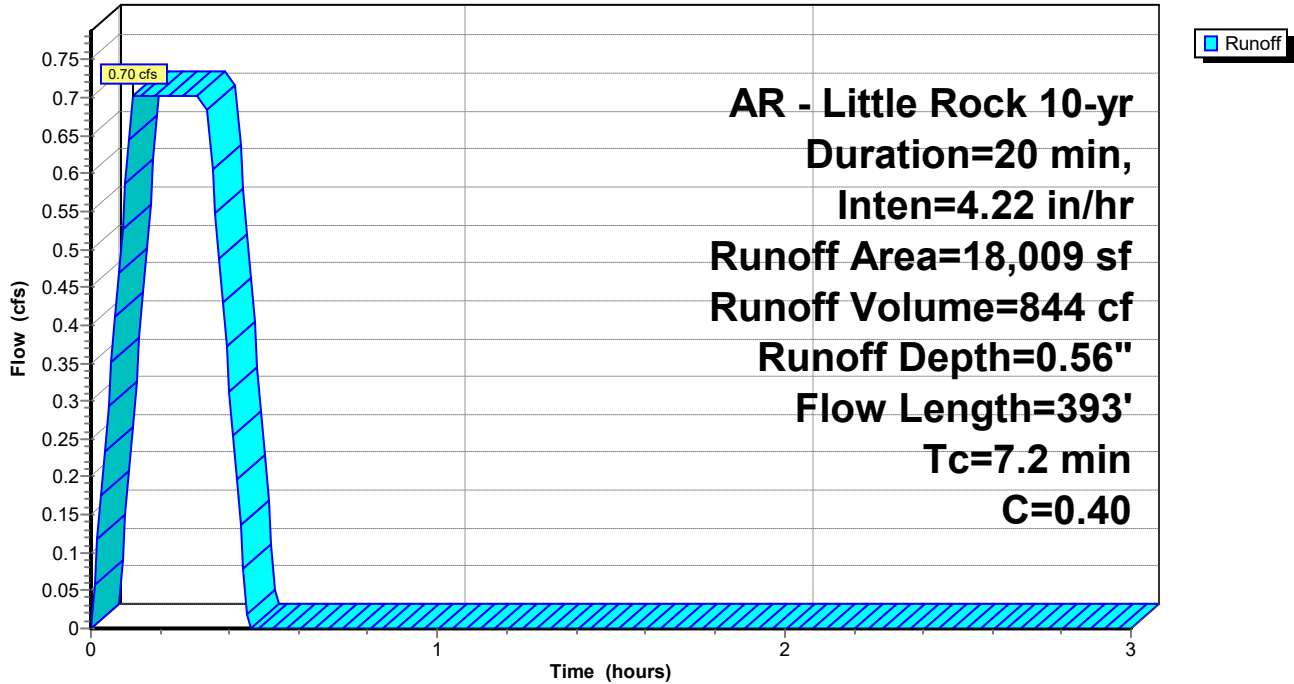

Goddard

Prepared by Phillip Lewis Engineering

HydroCAD® 10.20-5c s/n 12520 © 2023 HydroCAD Software Solutions LLC

AR - Little Rock 10-yr Duration=20 min, Inten=4.22 in/hr

Printed 3/25/2026

Summary for Subcatchment C2: Drainage Basin C2

Runoff = 2.58 cfs @ 0.09 hrs, Volume= 3,098 cf, Depth= 1.08"
 Routed to Pond CI-C2 : CI - C2

Runoff by Rational method, Rise/Fall=1.0/1.0 xTc, Time Span= 0.00-3.00 hrs, dt= 0.01 hrs
 AR - Little Rock 10-yr Duration=20 min, Inten=4.22 in/hr

Area (sf)	C	Description
11,376	0.40	Sod Yard
22,963	0.95	Roof, Paving, Sidewalks
34,339	0.77	Weighted Average
11,376		33.13% Pervious Area
22,963		66.87% Impervious Area

Tc (min)	Length (feet)	Slope (ft/ft)	Velocity (ft/sec)	Capacity (cfs)	Description
0.3	20	0.0200	1.14		Sheet Flow, Sheet Flow Smooth surfaces n= 0.011 P2= 4.19"
0.4	74	0.0240	3.14		Shallow Concentrated Flow, Concentrated Flow Paved Kv= 20.3 fps
0.1	17	0.0710	5.41		Shallow Concentrated Flow, Concentrated Flow Paved Kv= 20.3 fps
0.1	21	0.0610	5.01		Shallow Concentrated Flow, Concentrated Flow Paved Kv= 20.3 fps
0.6	148	0.0380	3.96		Shallow Concentrated Flow, Concentrated Flow Paved Kv= 20.3 fps
3.5	415		1.98		Direct Entry, Concentrated Flow (Min)
5.0	695	Total			

Subcatchment C2: Drainage Basin C2

Hydrograph

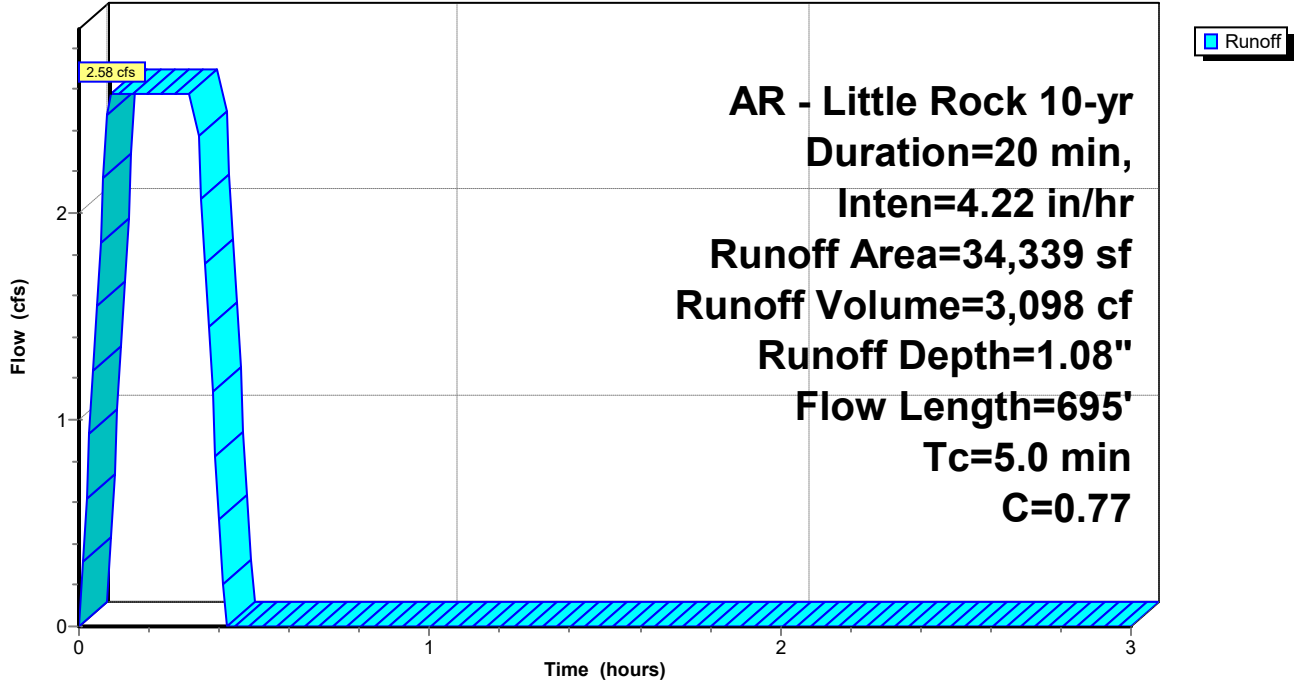

Goddard

Prepared by Phillip Lewis Engineering

HydroCAD® 10.20-5c s/n 12520 © 2023 HydroCAD Software Solutions LLC

AR - Little Rock 10-yr Duration=20 min, Inten=4.22 in/hr

Printed 3/25/2026

Summary for Subcatchment C20: Drainage Basin C20

Runoff = 1.20 cfs @ 0.14 hrs, Volume= 1,443 cf, Depth= 0.56"
 Routed to Link FINAL : APPROX DISCHARGE

Runoff by Rational method, Rise/Fall=1.0/1.0 xTc, Time Span= 0.00-3.00 hrs, dt= 0.01 hrs
 AR - Little Rock 10-yr Duration=20 min, Inten=4.22 in/hr

Area (sf)	C	Description
30,789	0.40	Sod Yard
0	0.95	Paving, Sidewalks
30,789	0.40	Weighted Average
30,789		100.00% Pervious Area

Tc (min)	Length (feet)	Slope (ft/ft)	Velocity (ft/sec)	Capacity (cfs)	Description
3.0	45	0.1430	0.25		Sheet Flow, Sheet Flow Grass: Dense n= 0.240 P2= 4.19"
4.5	55	0.0780	0.20		Sheet Flow, Sheet Flow Grass: Dense n= 0.240 P2= 4.19"
0.1	37	0.0780	4.19		Shallow Concentrated Flow, Concentrated Flow Grassed Waterway Kv= 15.0 fps
0.3	68	0.0710	4.00		Shallow Concentrated Flow, Concentrated Flow Grassed Waterway Kv= 15.0 fps
7.9	205	Total			

Subcatchment C20: Drainage Basin C20

Hydrograph

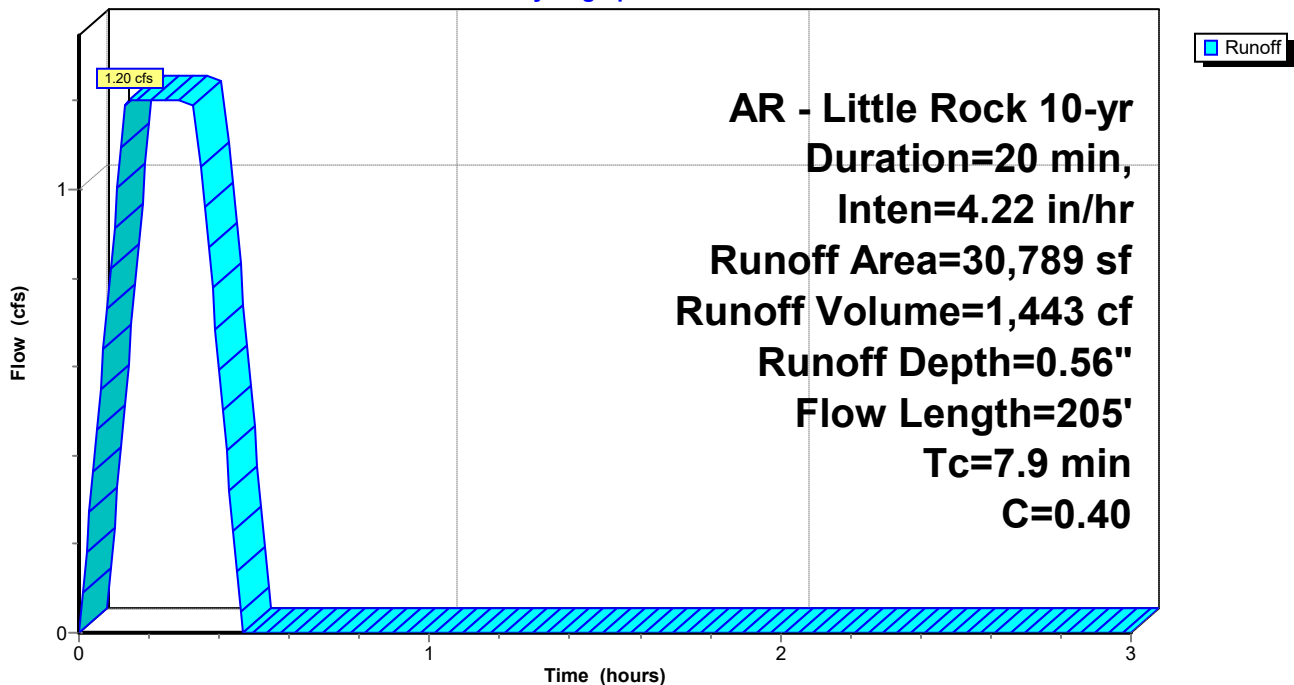

Goddard

Prepared by Phillip Lewis Engineering

HydroCAD® 10.20-5c s/n 12520 © 2023 HydroCAD Software Solutions LLC

AR - Little Rock 10-yr Duration=20 min, Inten=4.22 in/hr

Printed 3/25/2026

Summary for Subcatchment C3: Drainage Basin C3

Runoff = 0.32 cfs @ 0.09 hrs, Volume= 387 cf, Depth= 1.34"
 Routed to Pond CI-C3 : CI - C3

Runoff by Rational method, Rise/Fall=1.0/1.0 xTc, Time Span= 0.00-3.00 hrs, dt= 0.01 hrs
 AR - Little Rock 10-yr Duration=20 min, Inten=4.22 in/hr

Area (sf)	C	Description
0	0.40	Sod Yard
3,480	0.95	Paving, Sidewalks
3,480	0.95	Weighted Average
3,480		100.00% Impervious Area

Tc (min)	Length (feet)	Slope (ft/ft)	Velocity (ft/sec)	Capacity (cfs)	Description
0.3	22	0.0200	1.16		Sheet Flow, Sheet Flow Smooth surfaces n= 0.011 P2= 4.19"
0.0	10	0.0340	3.74		Shallow Concentrated Flow, Concentrated Flow Paved Kv= 20.3 fps
0.1	18	0.0390	4.01		Shallow Concentrated Flow, Concentrated Flow Paved Kv= 20.3 fps
0.6	147	0.0380	3.96		Shallow Concentrated Flow, Concentrated Flow Paved Kv= 20.3 fps
4.0	415		1.73		Direct Entry, Concentrated Flow (Min)
5.0	612	Total			

Subcatchment C3: Drainage Basin C3

Hydrograph

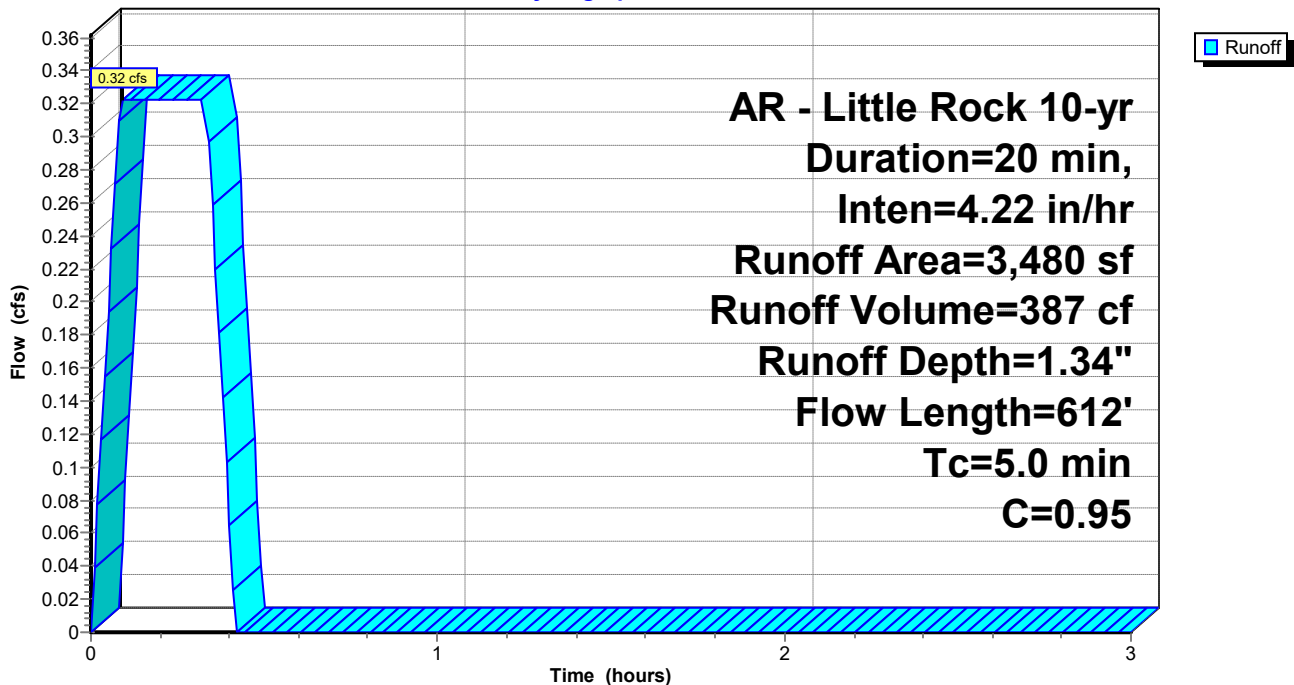

Goddard

Prepared by Phillip Lewis Engineering

HydroCAD® 10.20-5c s/n 12520 © 2023 HydroCAD Software Solutions LLC

AR - Little Rock 10-yr Duration=20 min, Inten=4.22 in/hr

Printed 3/25/2026

Summary for Subcatchment C4: Drainage Basin C4

Runoff = 0.62 cfs @ 0.09 hrs, Volume= 746 cf, Depth= 0.79"
 Routed to Pond CI-C3 : CI - C3

Runoff by Rational method, Rise/Fall=1.0/1.0 xTc, Time Span= 0.00-3.00 hrs, dt= 0.01 hrs
 AR - Little Rock 10-yr Duration=20 min, Inten=4.22 in/hr

Area (sf)	C	Description
8,130	0.40	Sod Yard
3,245	0.95	Paving, Sidewalks
11,375	0.56	Weighted Average
8,130		71.47% Pervious Area
3,245		28.53% Impervious Area

Tc (min)	Length (feet)	Slope (ft/ft)	Velocity (ft/sec)	Capacity (cfs)	Description
5.0	415		1.38		Direct Entry, Concentrated Flow (Min)

Subcatchment C4: Drainage Basin C4

Hydrograph

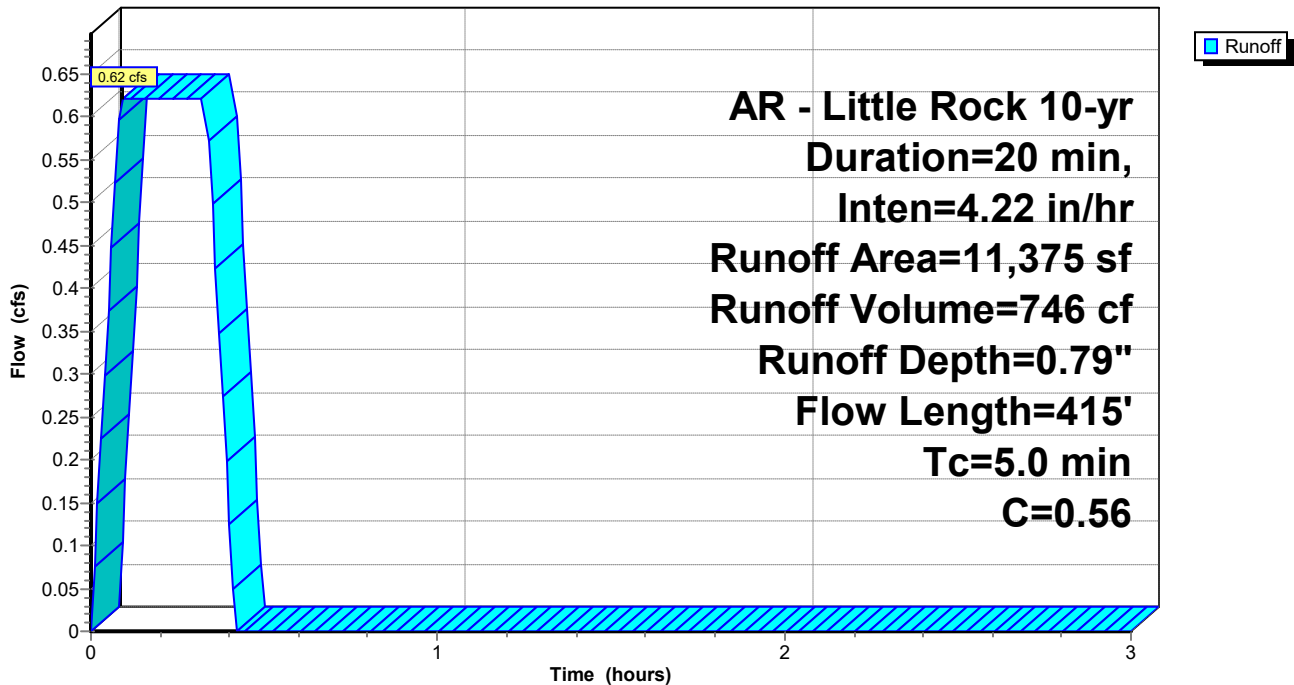

Goddard

Prepared by Phillip Lewis Engineering

HydroCAD® 10.20-5c s/n 12520 © 2023 HydroCAD Software Solutions LLC

AR - Little Rock 10-yr Duration=20 min, Inten=4.22 in/hr

Printed 3/25/2026

Summary for Subcatchment C5: Drainage Basin C5

Runoff = 0.54 cfs @ 0.10 hrs, Volume= 643 cf, Depth= 1.15"
 Routed to Pond CI-C4 : CI - C4

Runoff by Rational method, Rise/Fall=1.0/1.0 xTc, Time Span= 0.00-3.00 hrs, dt= 0.01 hrs
 AR - Little Rock 10-yr Duration=20 min, Inten=4.22 in/hr

Area (sf)	C	Description
1,634	0.40	Sod Yard
5,061	0.95	Paving, Sidewalks
6,695	0.82	Weighted Average
1,634		24.41% Pervious Area
5,061		75.59% Impervious Area

Tc (min)	Length (feet)	Slope (ft/ft)	Velocity (ft/sec)	Capacity (cfs)	Description
0.6	5	0.2990	0.14		Sheet Flow, Sheet Flow Grass: Bermuda n= 0.410 P2= 4.19"
0.2	12	0.0130	0.87		Sheet Flow, Sheet Flow Smooth surfaces n= 0.011 P2= 4.19"
3.9	8	0.0070	0.03		Sheet Flow, Sheet Flow Grass: Bermuda n= 0.410 P2= 4.19"
0.5	58	0.0080	1.82		Shallow Concentrated Flow, Concentrated Flow Paved Kv= 20.3 fps
0.1	14	0.0280	3.40		Shallow Concentrated Flow, Concentrated Flow Paved Kv= 20.3 fps
0.1	23	0.0370	3.90		Shallow Concentrated Flow, Concentrated Flow Paved Kv= 20.3 fps
0.0	13	0.0940	6.22		Shallow Concentrated Flow, Concentrated Flow Paved Kv= 20.3 fps
0.0	13	0.0560	4.80		Shallow Concentrated Flow, Concentrated Flow Paved Kv= 20.3 fps
0.2	30	0.0180	2.72		Shallow Concentrated Flow, Concentrated Flow Paved Kv= 20.3 fps
5.6	176	Total			

Subcatchment C5: Drainage Basin C5

Hydrograph

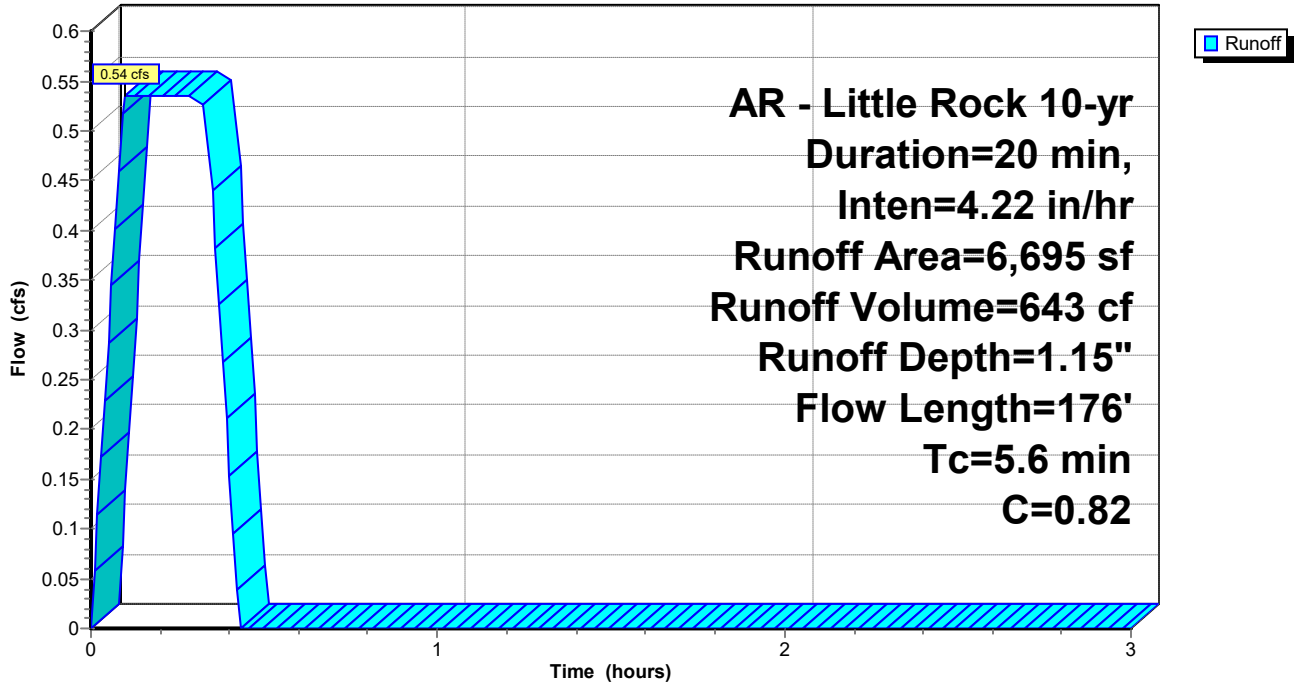

Goddard

Prepared by Phillip Lewis Engineering

HydroCAD® 10.20-5c s/n 12520 © 2023 HydroCAD Software Solutions LLC

AR - Little Rock 10-yr Duration=20 min, Inten=4.22 in/hr

Printed 3/25/2026

Summary for Subcatchment C6: Drainage Basin C6

Runoff = 0.26 cfs @ 0.09 hrs, Volume= 316 cf, Depth= 1.34"
 Routed to Pond CI-C5 : CI - C5

Runoff by Rational method, Rise/Fall=1.0/1.0 xTc, Time Span= 0.00-3.00 hrs, dt= 0.01 hrs
 AR - Little Rock 10-yr Duration=20 min, Inten=4.22 in/hr

Area (sf)	C	Description
0	0.40	Sod Yard
2,835	0.95	Paving, Sidewalks
2,835	0.95	Weighted Average
2,835		100.00% Impervious Area

Tc (min)	Length (feet)	Slope (ft/ft)	Velocity (ft/sec)	Capacity (cfs)	Description
0.3	22	0.0200	1.16		Sheet Flow, Sheet Flow Smooth surfaces n= 0.011 P2= 4.19"
0.2	19	0.0100	2.03		Shallow Concentrated Flow, Concentrated Flow Paved Kv= 20.3 fps
0.1	17	0.0170	2.65		Shallow Concentrated Flow, Concentrated Flow Paved Kv= 20.3 fps
0.1	26	0.0360	3.85		Shallow Concentrated Flow, Concentrated Flow Paved Kv= 20.3 fps
0.1	28	0.0610	5.01		Shallow Concentrated Flow, Concentrated Flow Paved Kv= 20.3 fps
0.1	27	0.0610	5.01		Shallow Concentrated Flow, Concentrated Flow Paved Kv= 20.3 fps
4.1	415		1.69		Direct Entry, Concentrated Flow (Min)
5.0	554	Total			

Subcatchment C6: Drainage Basin C6

Hydrograph



Goddard

Prepared by Phillip Lewis Engineering

HydroCAD® 10.20-5c s/n 12520 © 2023 HydroCAD Software Solutions LLC

AR - Little Rock 10-yr Duration=20 min, Inten=4.22 in/hr

Printed 3/25/2026

Summary for Subcatchment C7: Drainage Basin C7

Runoff = 0.15 cfs @ 0.09 hrs, Volume= 178 cf, Depth= 1.34"
 Routed to Pond CI-D1 : CI - D1

Runoff by Rational method, Rise/Fall=1.0/1.0 xTc, Time Span= 0.00-3.00 hrs, dt= 0.01 hrs
 AR - Little Rock 10-yr Duration=20 min, Inten=4.22 in/hr

Area (sf)	C	Description
0	0.40	Sod Yard
1,597	0.95	Paving, Sidewalks
1,597	0.95	Weighted Average
1,597		100.00% Impervious Area

Tc (min)	Length (feet)	Slope (ft/ft)	Velocity (ft/sec)	Capacity (cfs)	Description
0.3	19	0.0200	1.13		Sheet Flow, Sheet Flow Smooth surfaces n= 0.011 P2= 4.19"
0.1	16	0.0540	4.72		Shallow Concentrated Flow, Concentrated Flow Paved Kv= 20.3 fps
0.3	81	0.0580	4.89		Shallow Concentrated Flow, Concentrated Flow Paved Kv= 20.3 fps
4.3	415		1.61		Direct Entry, Concentrated Flow (Min)
5.0	531	Total			

Subcatchment C7: Drainage Basin C7

Hydrograph

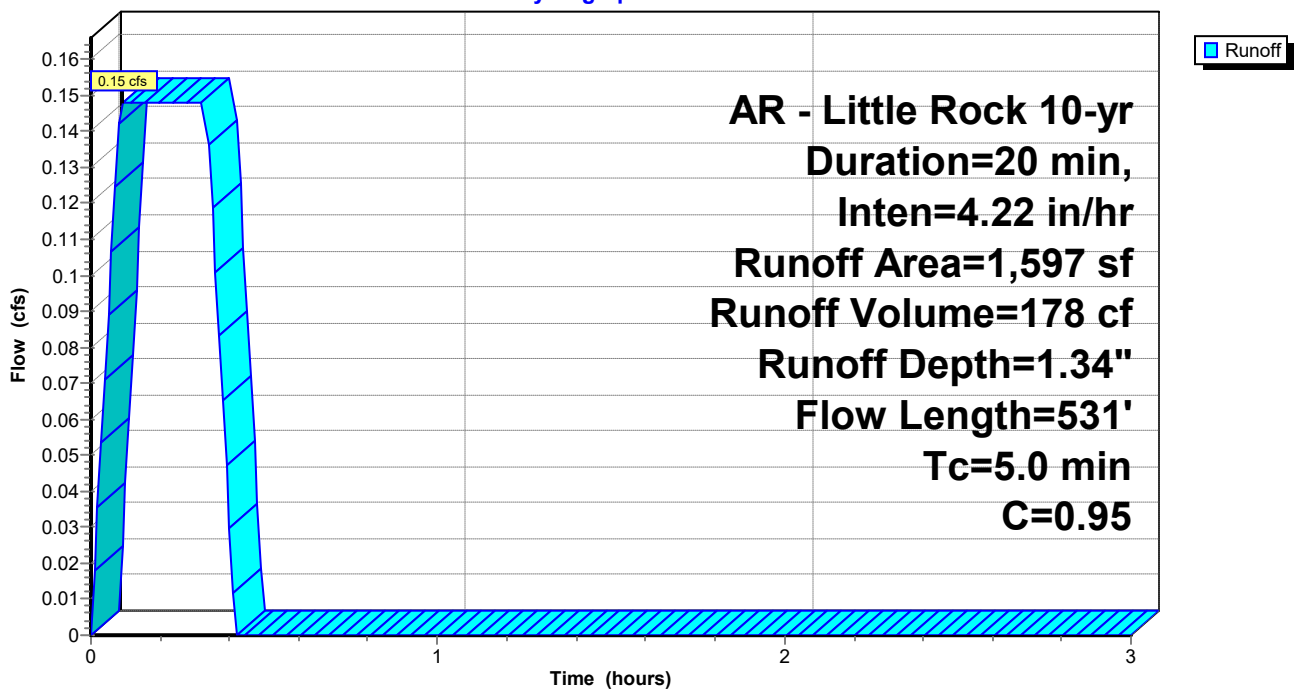

Summary for Subcatchment C8: Drainage Basin C8

Runoff = 0.14 cfs @ 0.09 hrs, Volume= 172 cf, Depth= 1.34"
 Routed to Pond CI-D2 : CI - D2

Runoff by Rational method, Rise/Fall=1.0/1.0 xTc, Time Span= 0.00-3.00 hrs, dt= 0.01 hrs
 AR - Little Rock 10-yr Duration=20 min, Inten=4.22 in/hr

Area (sf)	C	Description
0	0.40	Sod Yard
1,548	0.95	Paving, Sidewalks
1,548	0.95	Weighted Average
1,548		100.00% Impervious Area

Tc (min)	Length (feet)	Slope (ft/ft)	Velocity (ft/sec)	Capacity (cfs)	Description
0.3	18	0.0200	1.12		Sheet Flow, Sheet Flow Smooth surfaces n= 0.011 P2= 4.19"
0.3	94	0.0610	5.01		Shallow Concentrated Flow, Concentrated Flow Paved Kv= 20.3 fps
4.4	415		1.57		Direct Entry, Concentrated Flow (Min)
5.0	527	Total			

Subcatchment C8: Drainage Basin C8

Hydrograph

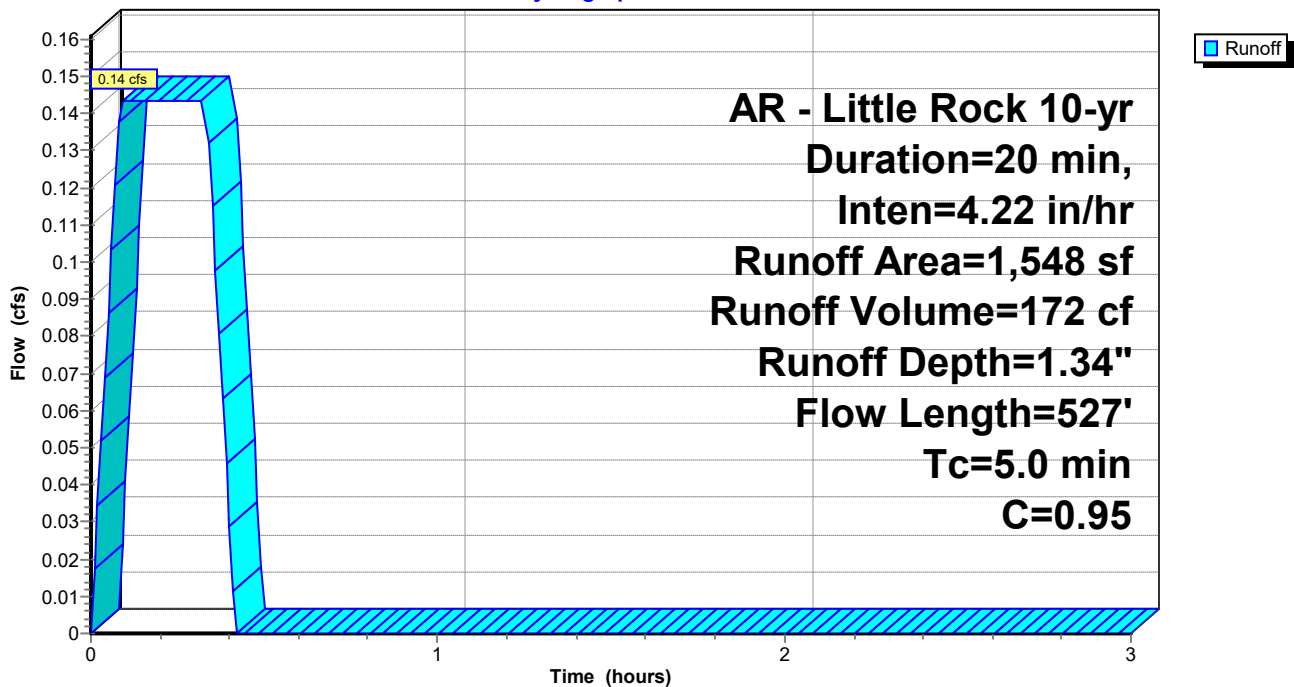

Goddard

Prepared by Phillip Lewis Engineering

HydroCAD® 10.20-5c s/n 12520 © 2023 HydroCAD Software Solutions LLC

AR - Little Rock 10-yr Duration=20 min, Inten=4.22 in/hr

Printed 3/25/2026

Summary for Subcatchment C9: Drainage Basin C9

Runoff = 1.04 cfs @ 0.09 hrs, Volume= 1,246 cf, Depth= 1.08"
 Routed to Pond CI-C6 : CI - C6

Runoff by Rational method, Rise/Fall=1.0/1.0 xTc, Time Span= 0.00-3.00 hrs, dt= 0.01 hrs
 AR - Little Rock 10-yr Duration=20 min, Inten=4.22 in/hr

Area (sf)	C	Description
4,456	0.40	Sod Yard
9,361	0.95	Paving, Sidewalks
13,817	0.77	Weighted Average
4,456		32.25% Pervious Area
9,361		67.75% Impervious Area

Tc (min)	Length (feet)	Slope (ft/ft)	Velocity (ft/sec)	Capacity (cfs)	Description
1.2	100	0.0140	1.36		Sheet Flow, Sheet Flow Smooth surfaces n= 0.011 P2= 4.19"
0.1	13	0.0150	2.49		Shallow Concentrated Flow, Concentrated Flow Paved Kv= 20.3 fps
0.1	23	0.0160	2.57		Shallow Concentrated Flow, Concentrated Flow Paved Kv= 20.3 fps
0.1	7	0.0050	1.44		Shallow Concentrated Flow, Concentrated Flow Paved Kv= 20.3 fps
0.1	8	0.0100	2.03		Shallow Concentrated Flow, Concentrated Flow Paved Kv= 20.3 fps
0.2	41	0.0420	4.16		Shallow Concentrated Flow, Concentrated Flow Paved Kv= 20.3 fps
0.1	41	0.0540	4.72		Shallow Concentrated Flow, Concentrated Flow Paved Kv= 20.3 fps
0.2	61	0.0520	4.63		Shallow Concentrated Flow, Concentrated Flow Paved Kv= 20.3 fps
2.9	415		2.39		Direct Entry, Concentrated Flow (Min)
5.0	709	Total			

Subcatchment C9: Drainage Basin C9

Hydrograph

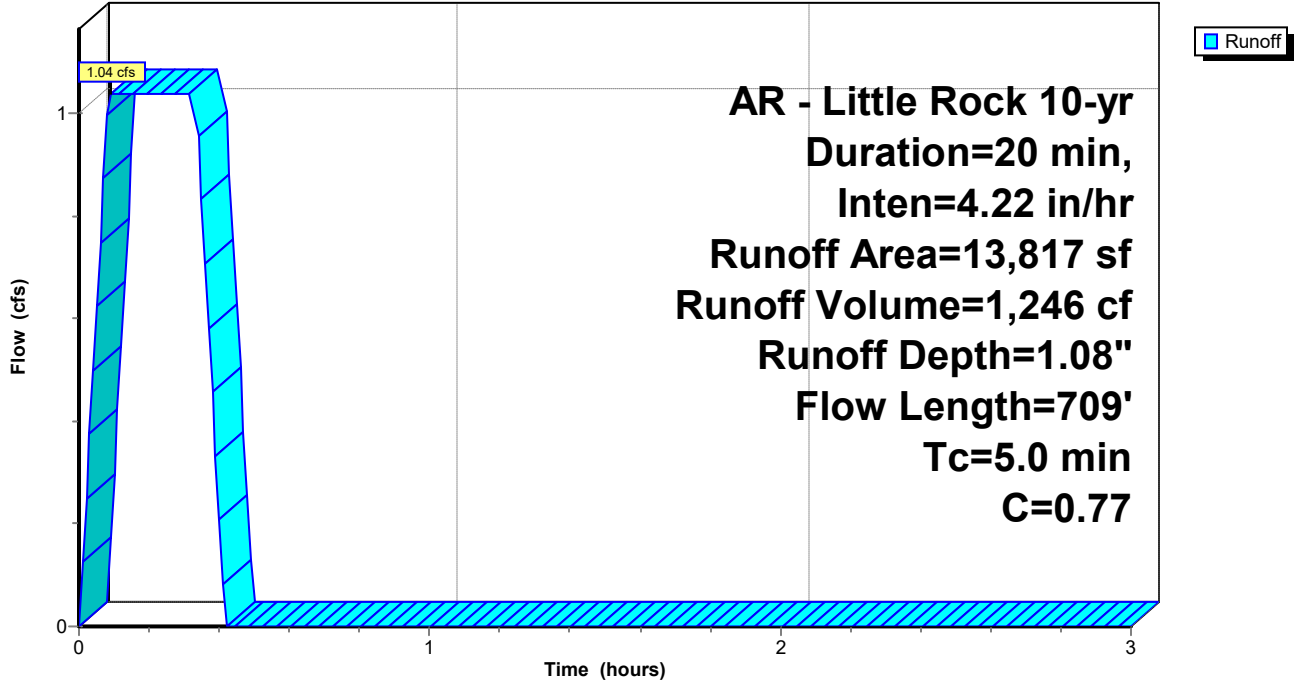

Summary for Pond CI-A1: CI - A1

Inflow Area = 19,493 sf, 74.78% Impervious, Inflow Depth = 1.18" for 10-yr event
Inflow = 1.60 cfs @ 0.09 hrs, Volume= 1,918 cf
Primary = 1.60 cfs @ 0.09 hrs, Volume= 1,918 cf, Atten= 0%, Lag= 0.0 min
Routed to Pond JB-A2 : JB - A2

Routing by Stor-Ind method, Time Span= 0.00-3.00 hrs, dt= 0.01 hrs

Pond CI-A1: CI - A1

Hydrograph

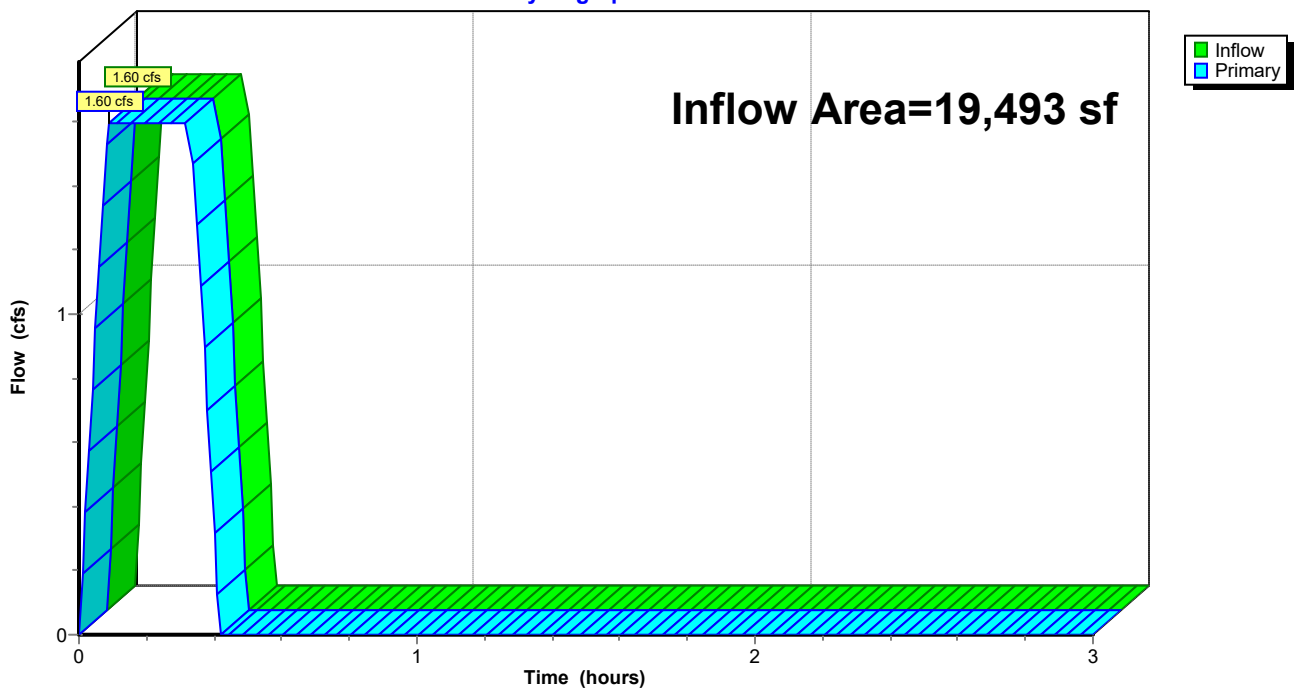

Summary for Pond CI-A3: CI - A3

Inflow Area = 52,824 sf, 61.20% Impervious, Inflow Depth = 1.10" for 10-yr event
Inflow = 4.02 cfs @ 0.17 hrs, Volume= 4,823 cf
Primary = 4.02 cfs @ 0.17 hrs, Volume= 4,823 cf, Atten= 0%, Lag= 0.0 min
Routed to Pond CI-A4 : CI - A4

Routing by Stor-Ind method, Time Span= 0.00-3.00 hrs, dt= 0.01 hrs

Pond CI-A3: CI - A3

Hydrograph

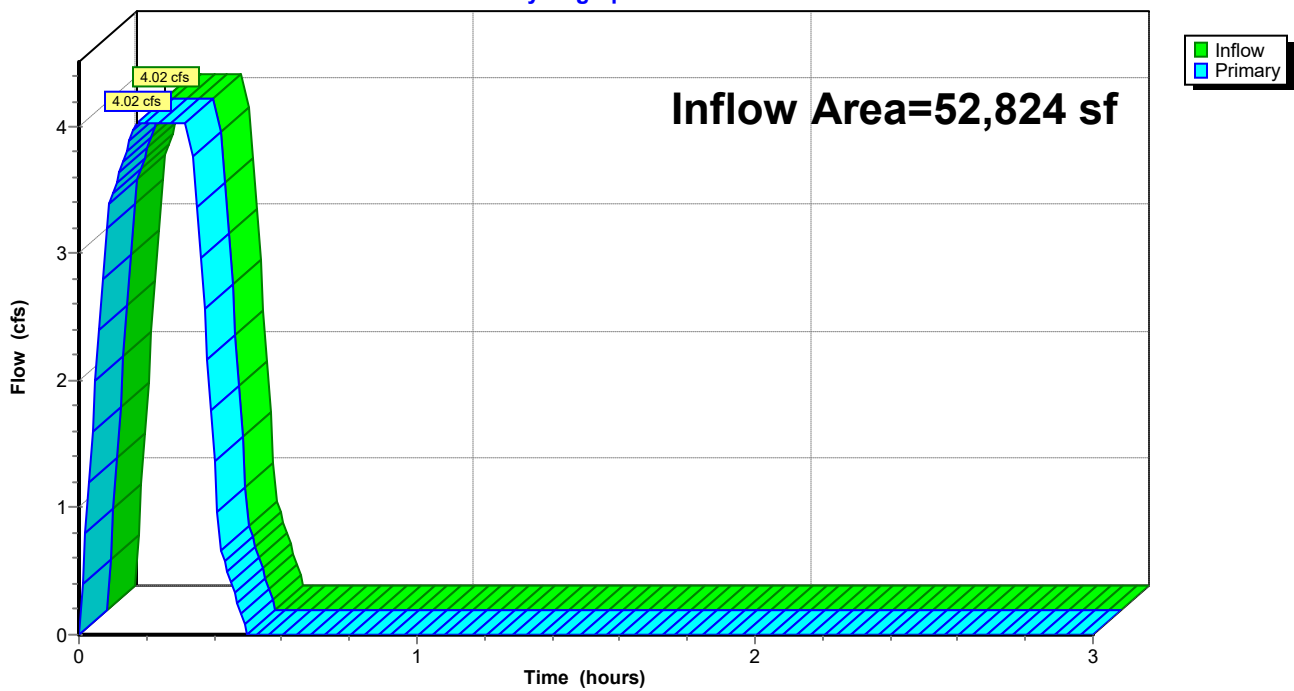

Summary for Pond CI-A4: CI - A4

Inflow Area = 75,210 sf, 60.06% Impervious, Inflow Depth = 1.09" for 10-yr event
Inflow = 5.67 cfs @ 0.24 hrs, Volume= 6,806 cf
Primary = 5.67 cfs @ 0.24 hrs, Volume= 6,806 cf, Atten= 0%, Lag= 0.0 min
Routed to Pond CI-A5 : CI - A5

Routing by Stor-Ind method, Time Span= 0.00-3.00 hrs, dt= 0.01 hrs

Pond CI-A4: CI - A4

Hydrograph

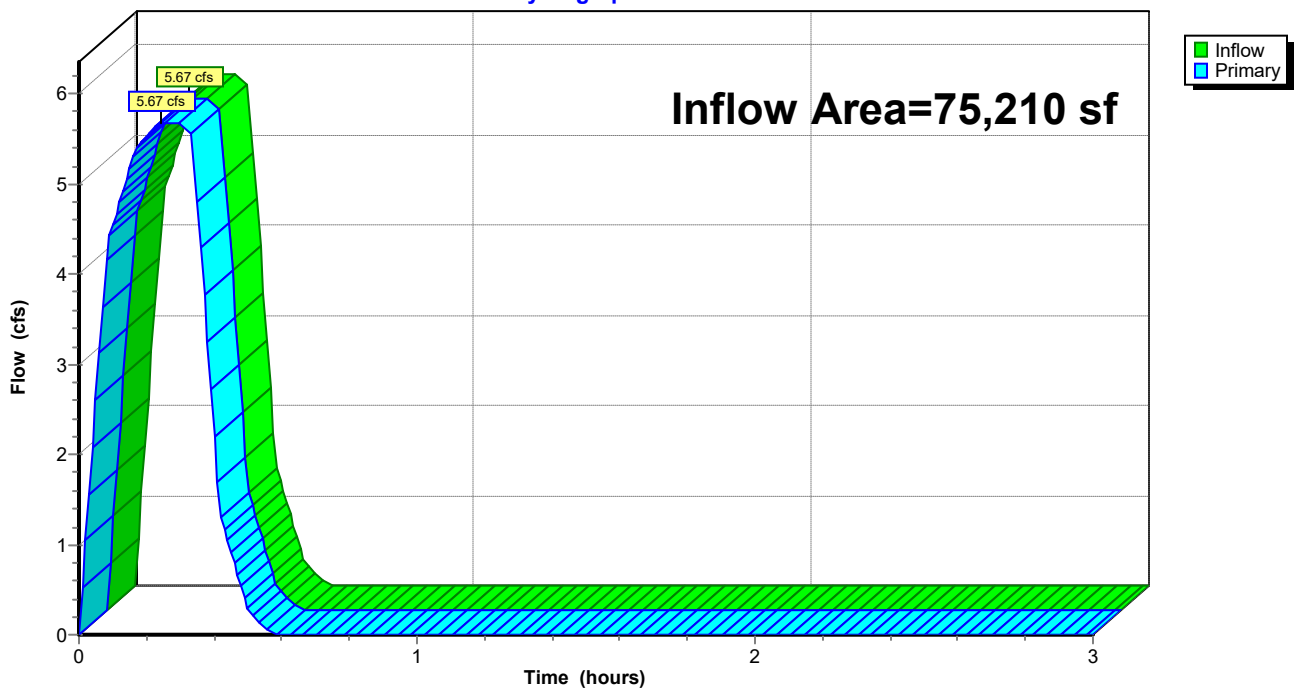

Summary for Pond CI-A5: CI - A5

Inflow Area = 97,235 sf, 62.81% Impervious, Inflow Depth = 1.09" for 10-yr event
Inflow = 7.39 cfs @ 0.27 hrs, Volume= 8,871 cf
Primary = 7.39 cfs @ 0.27 hrs, Volume= 8,871 cf, Atten= 0%, Lag= 0.0 min
Routed to Pond DP : Existing North Detention Pond

Routing by Stor-Ind method, Time Span= 0.00-3.00 hrs, dt= 0.01 hrs

Pond CI-A5: CI - A5

Hydrograph

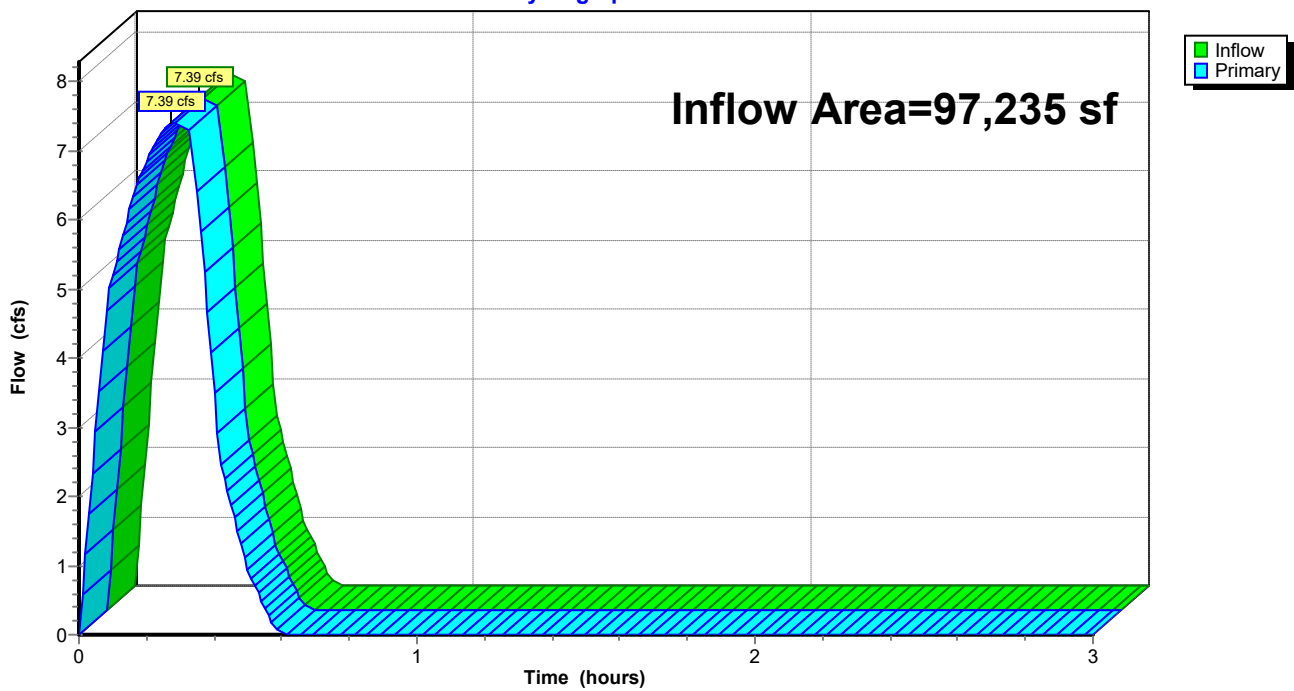

Summary for Pond CI-B2: CI - B2

Inflow Area = 22,169 sf, 29.72% Impervious, Inflow Depth = 0.90" for 10-yr event
Inflow = 1.39 cfs @ 0.17 hrs, Volume= 1,662 cf
Primary = 1.39 cfs @ 0.17 hrs, Volume= 1,662 cf, Atten= 0%, Lag= 0.0 min
Routed to Pond JB-A2 : JB - A2

Routing by Stor-Ind method, Time Span= 0.00-3.00 hrs, dt= 0.01 hrs

Pond CI-B2: CI - B2

Hydrograph

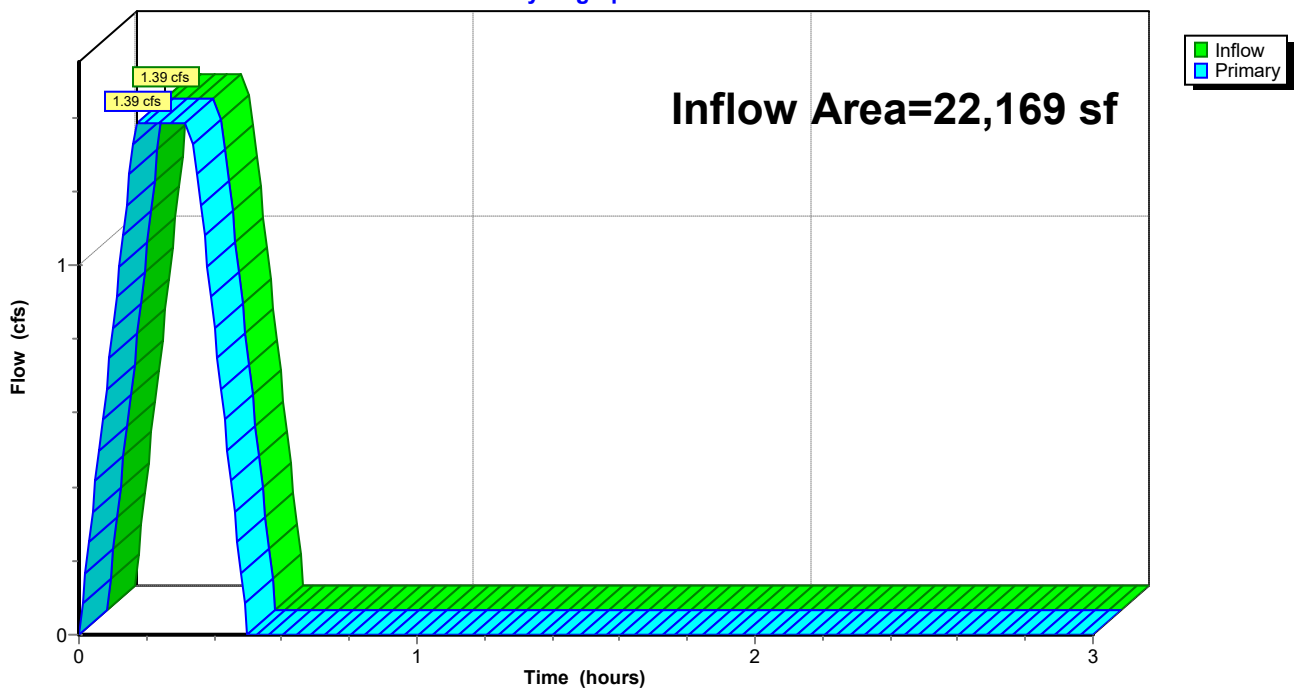

Summary for Pond CI-C1: CI - C1

Inflow Area = 20,337 sf, 69.83% Impervious, Inflow Depth = 1.10" for 10-yr event
Inflow = 1.55 cfs @ 0.09 hrs, Volume= 1,858 cf
Primary = 1.55 cfs @ 0.09 hrs, Volume= 1,858 cf, Atten= 0%, Lag= 0.0 min
Routed to Pond CI-C2 : CI - C2

Routing by Stor-Ind method, Time Span= 0.00-3.00 hrs, dt= 0.01 hrs

Pond CI-C1: CI - C1

Hydrograph

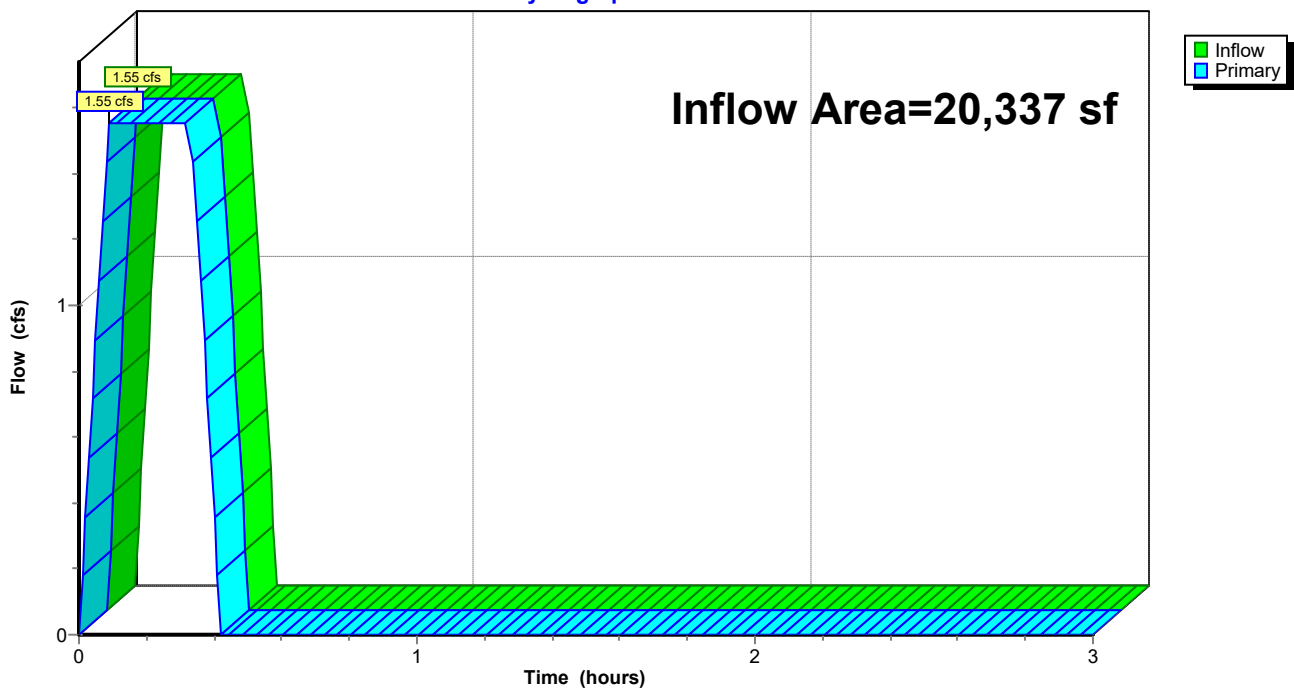

Summary for Pond CI-C2: CI - C2

Inflow Area = 54,676 sf, 67.97% Impervious, Inflow Depth = 1.09" for 10-yr event
Inflow = 4.13 cfs @ 0.09 hrs, Volume= 4,956 cf
Primary = 4.13 cfs @ 0.09 hrs, Volume= 4,956 cf, Atten= 0%, Lag= 0.0 min
Routed to Pond CI-C3 : CI - C3

Routing by Stor-Ind method, Time Span= 0.00-3.00 hrs, dt= 0.01 hrs

Pond CI-C2: CI - C2

Hydrograph

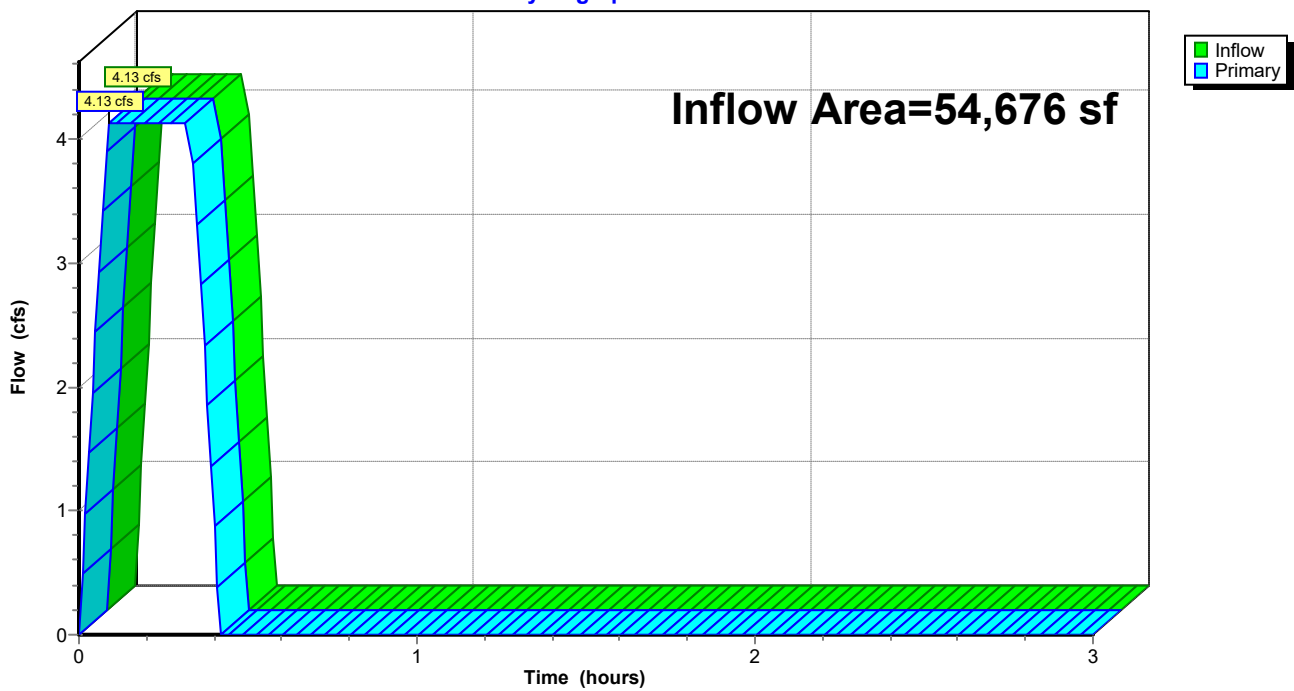

Summary for Pond CI-C3: CI - C3

Inflow Area = 69,531 sf, 63.12% Impervious, Inflow Depth = 1.05" for 10-yr event
Inflow = 5.08 cfs @ 0.09 hrs, Volume= 6,089 cf
Primary = 5.08 cfs @ 0.09 hrs, Volume= 6,089 cf, Atten= 0%, Lag= 0.0 min
Routed to Pond CI-C4 : CI - C4

Routing by Stor-Ind method, Time Span= 0.00-3.00 hrs, dt= 0.01 hrs

Pond CI-C3: CI - C3

Hydrograph

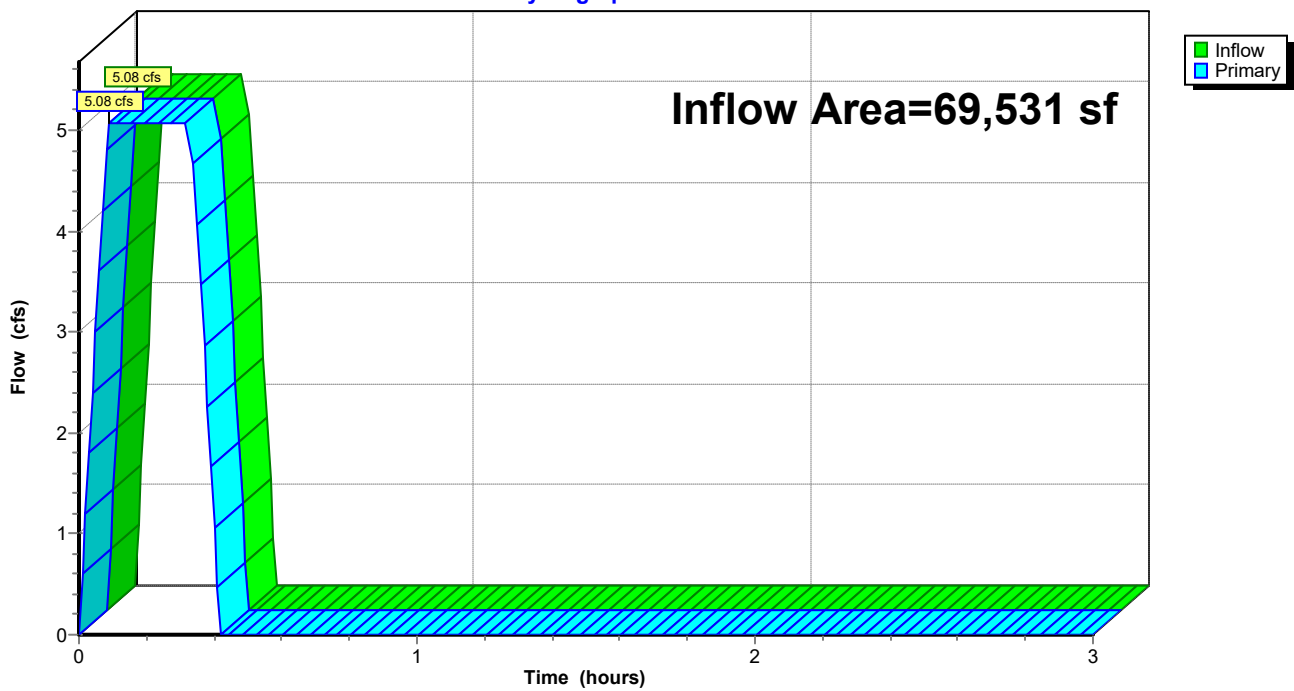

Summary for Pond CI-C4: CI - C4

Inflow Area = 76,226 sf, 64.22% Impervious, Inflow Depth = 1.06" for 10-yr event
Inflow = 5.61 cfs @ 0.10 hrs, Volume= 6,732 cf
Primary = 5.61 cfs @ 0.10 hrs, Volume= 6,732 cf, Atten= 0%, Lag= 0.0 min
Routed to Pond CI-C5 : CI - C5

Routing by Stor-Ind method, Time Span= 0.00-3.00 hrs, dt= 0.01 hrs

Pond CI-C4: CI - C4

Hydrograph

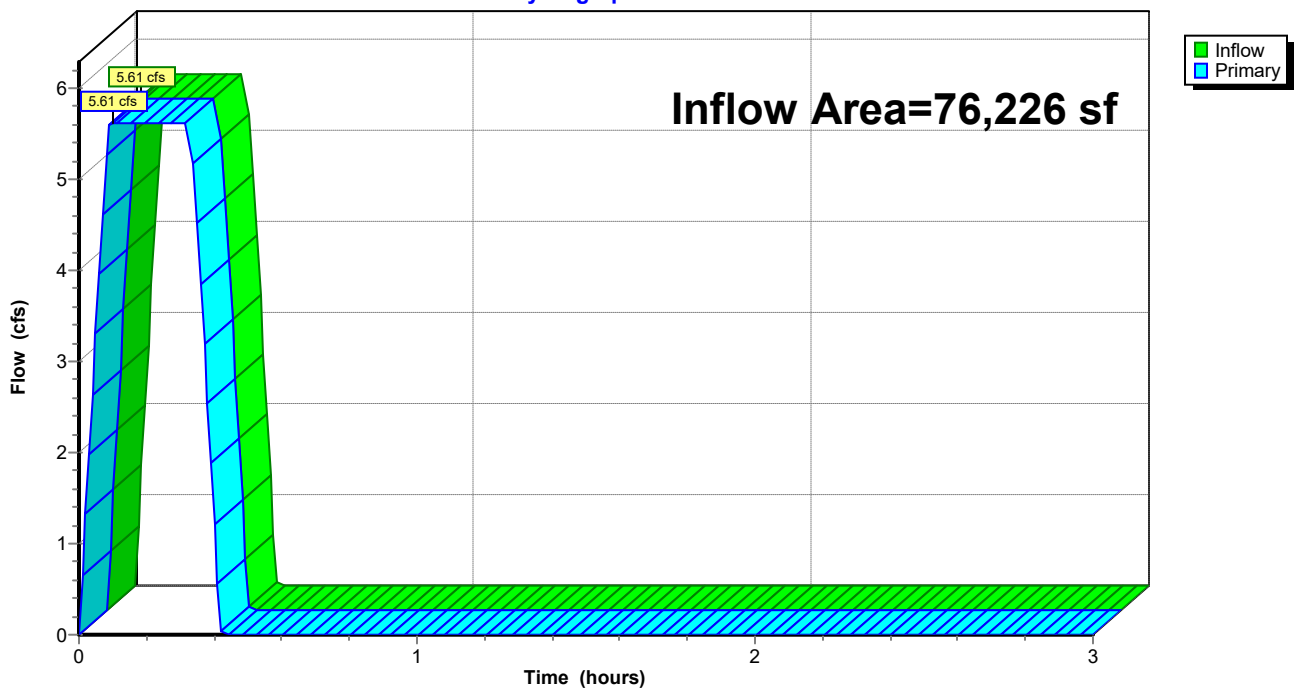

Summary for Pond CI-C5: CI - C5

Inflow Area = 79,061 sf, 65.50% Impervious, Inflow Depth = 1.07" for 10-yr event
Inflow = 5.88 cfs @ 0.10 hrs, Volume= 7,048 cf
Primary = 5.88 cfs @ 0.10 hrs, Volume= 7,048 cf, Atten= 0%, Lag= 0.0 min
Routed to Pond CI-C6 : CI - C6

Routing by Stor-Ind method, Time Span= 0.00-3.00 hrs, dt= 0.01 hrs

Pond CI-C5: CI - C5

Hydrograph

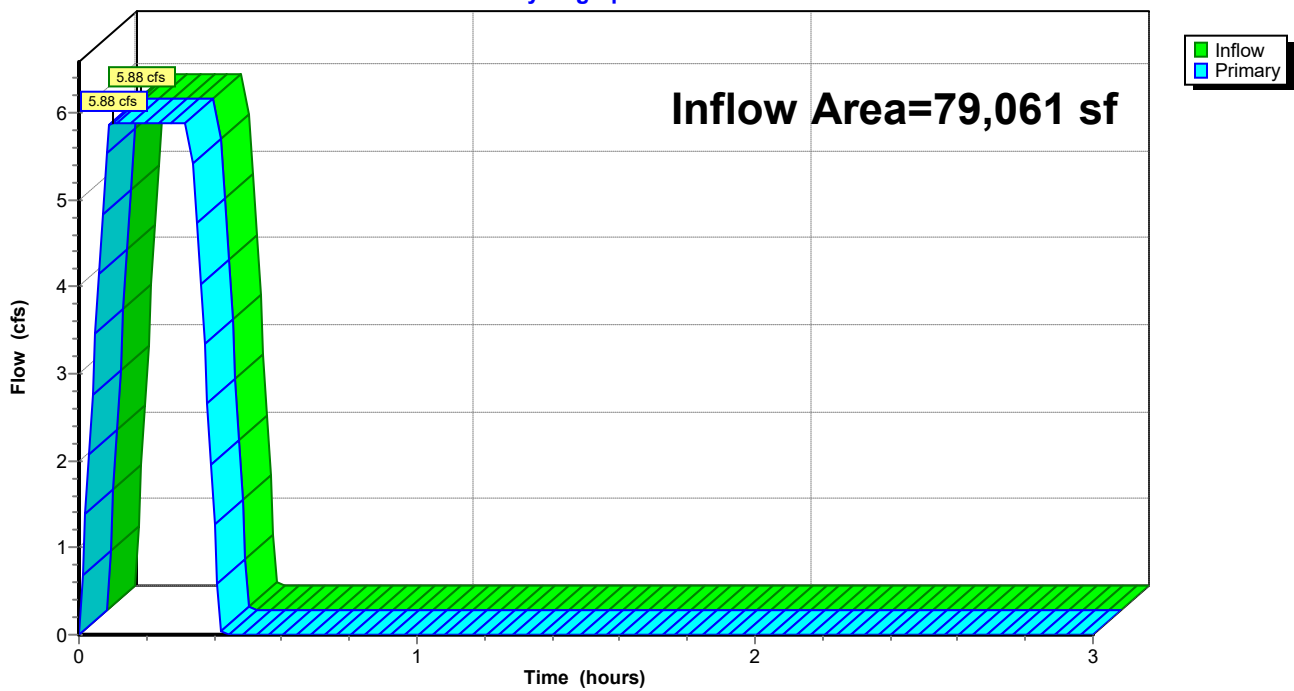

Summary for Pond CI-C6: CI - C6

Inflow Area = 96,023 sf, 66.95% Impervious, Inflow Depth = 1.08" for 10-yr event
Inflow = 7.21 cfs @ 0.10 hrs, Volume= 8,644 cf
Primary = 7.21 cfs @ 0.10 hrs, Volume= 8,644 cf, Atten= 0%, Lag= 0.0 min
Routed to Pond CI-C7 : CI - C7

Routing by Stor-Ind method, Time Span= 0.00-3.00 hrs, dt= 0.01 hrs

Pond CI-C6: CI - C6

Hydrograph

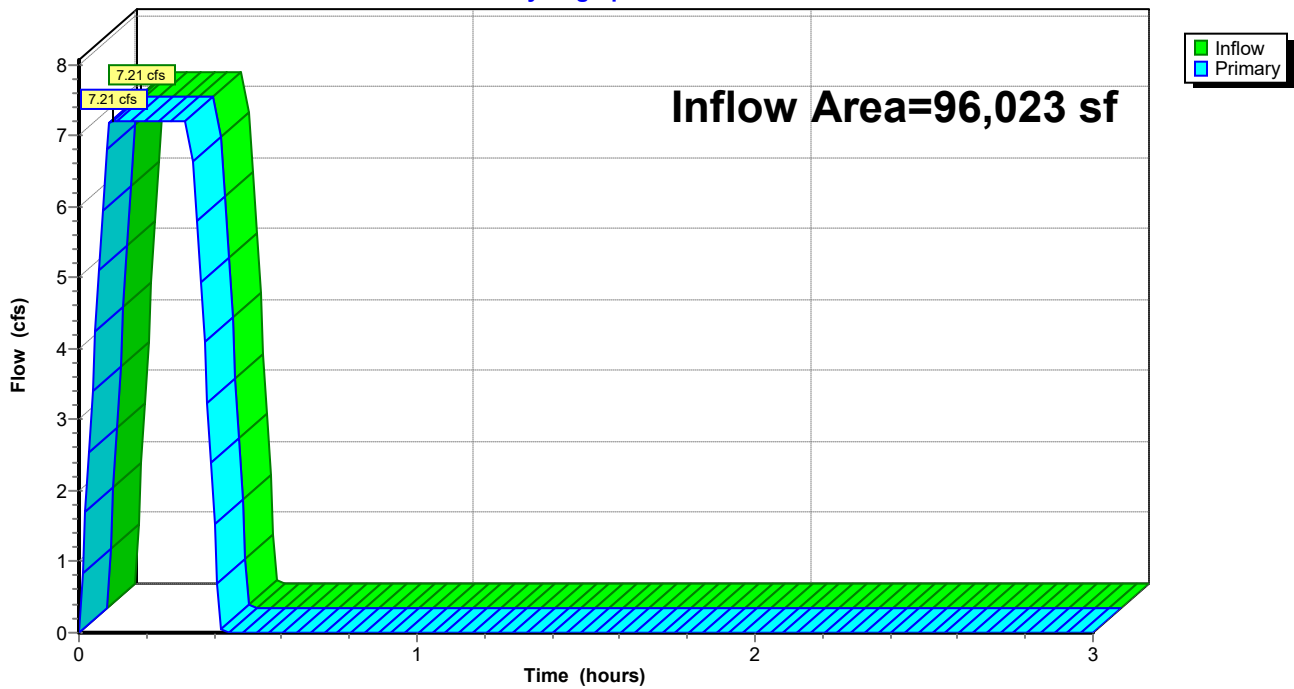

Summary for Pond CI-C7: CI - C7

Inflow Area = 133,272 sf, 67.70% Impervious, Inflow Depth = 1.09" for 10-yr event
Inflow = 10.07 cfs @ 0.10 hrs, Volume= 12,075 cf
Primary = 10.07 cfs @ 0.10 hrs, Volume= 12,075 cf, Atten= 0%, Lag= 0.0 min
Routed to Pond DP : Existing North Detention Pond

Routing by Stor-Ind method, Time Span= 0.00-3.00 hrs, dt= 0.01 hrs

Pond CI-C7: CI - C7

Hydrograph

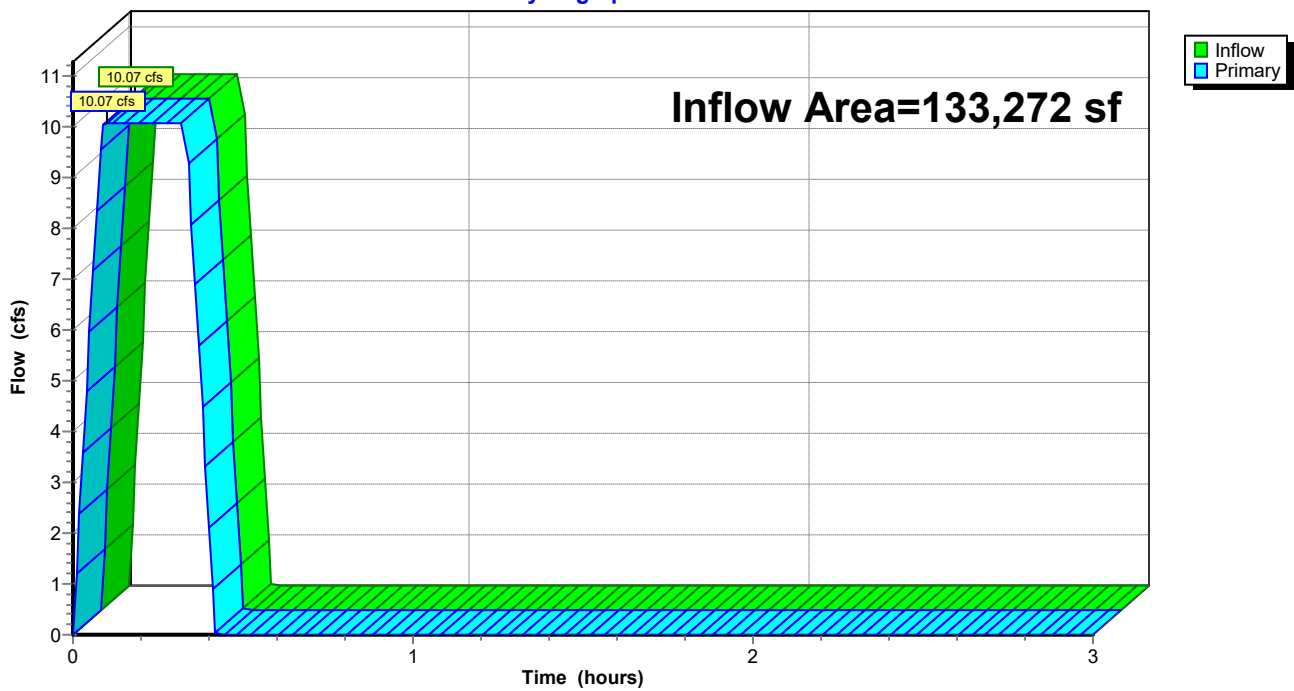

Summary for Pond CI-D1: CI - D1

Inflow Area = 1,597 sf, 100.00% Impervious, Inflow Depth = 1.34" for 10-yr event
Inflow = 0.15 cfs @ 0.09 hrs, Volume= 178 cf
Primary = 0.15 cfs @ 0.09 hrs, Volume= 178 cf, Atten= 0%, Lag= 0.0 min
Routed to Pond CI-D2 : CI - D2

Routing by Stor-Ind method, Time Span= 0.00-3.00 hrs, dt= 0.01 hrs

Pond CI-D1: CI - D1

Hydrograph

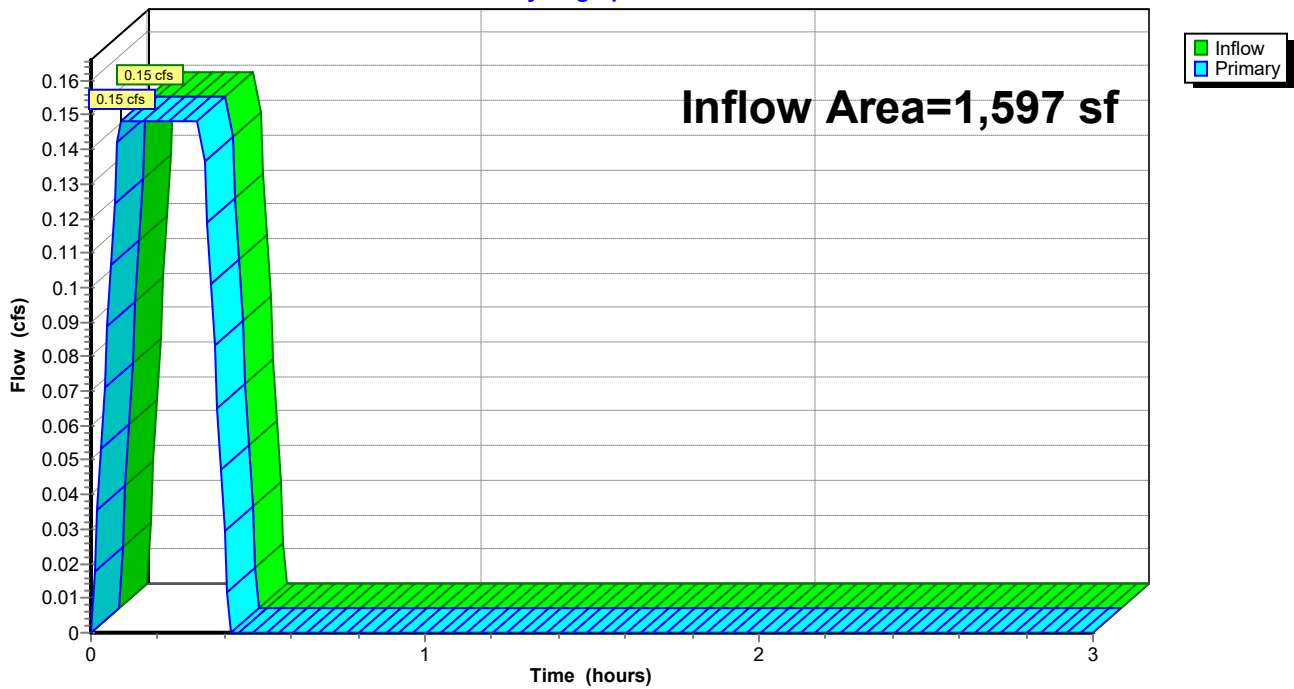

Summary for Pond CI-D2: CI - D2

Inflow Area = 3,145 sf, 100.00% Impervious, Inflow Depth = 1.34" for 10-yr event
Inflow = 0.29 cfs @ 0.09 hrs, Volume= 350 cf
Primary = 0.29 cfs @ 0.09 hrs, Volume= 350 cf, Atten= 0%, Lag= 0.0 min
Routed to Pond CI-C6 : CI - C6

Routing by Stor-Ind method, Time Span= 0.00-3.00 hrs, dt= 0.01 hrs

Pond CI-D2: CI - D2

Hydrograph

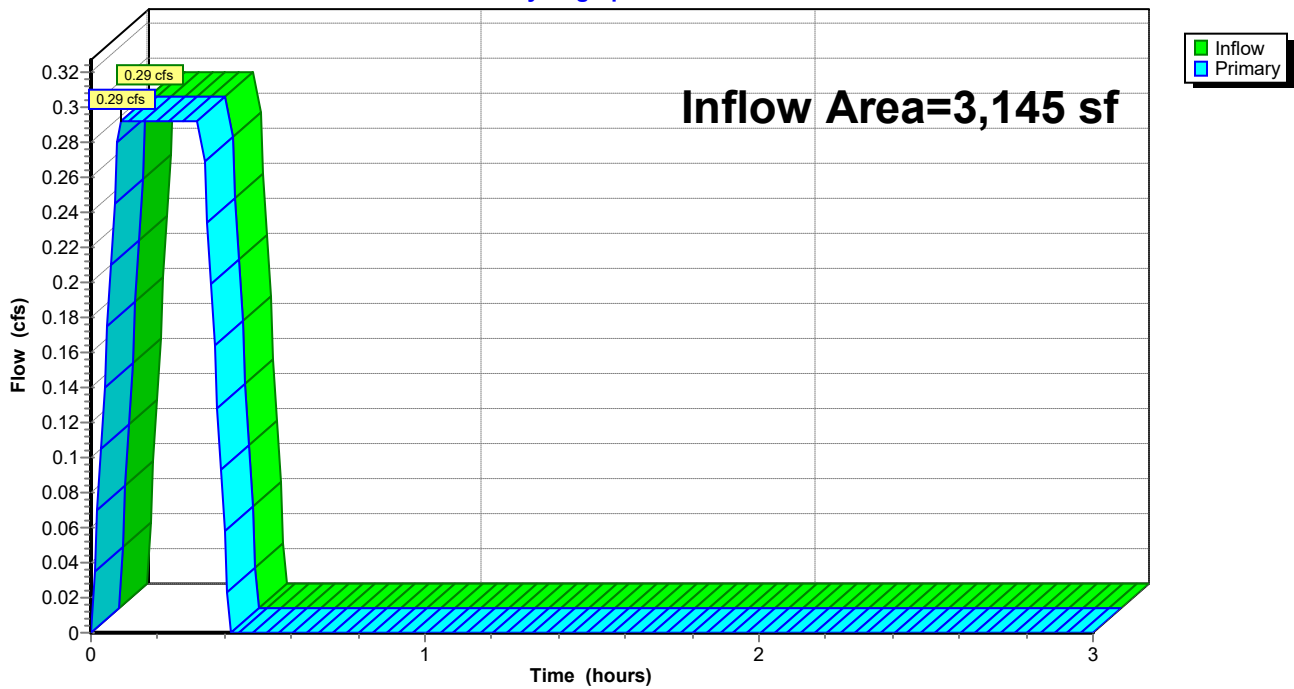

Summary for Pond CI-E1: CI - E1

Inflow Area = 5,408 sf, 77.35% Impervious, Inflow Depth = 1.17" for 10-yr event
Inflow = 0.44 cfs @ 0.09 hrs, Volume= 526 cf
Primary = 0.44 cfs @ 0.09 hrs, Volume= 526 cf, Atten= 0%, Lag= 0.0 min
Routed to Pond CI-E2 : CI - E2

Routing by Stor-Ind method, Time Span= 0.00-3.00 hrs, dt= 0.01 hrs

Pond CI-E1: CI - E1

Hydrograph

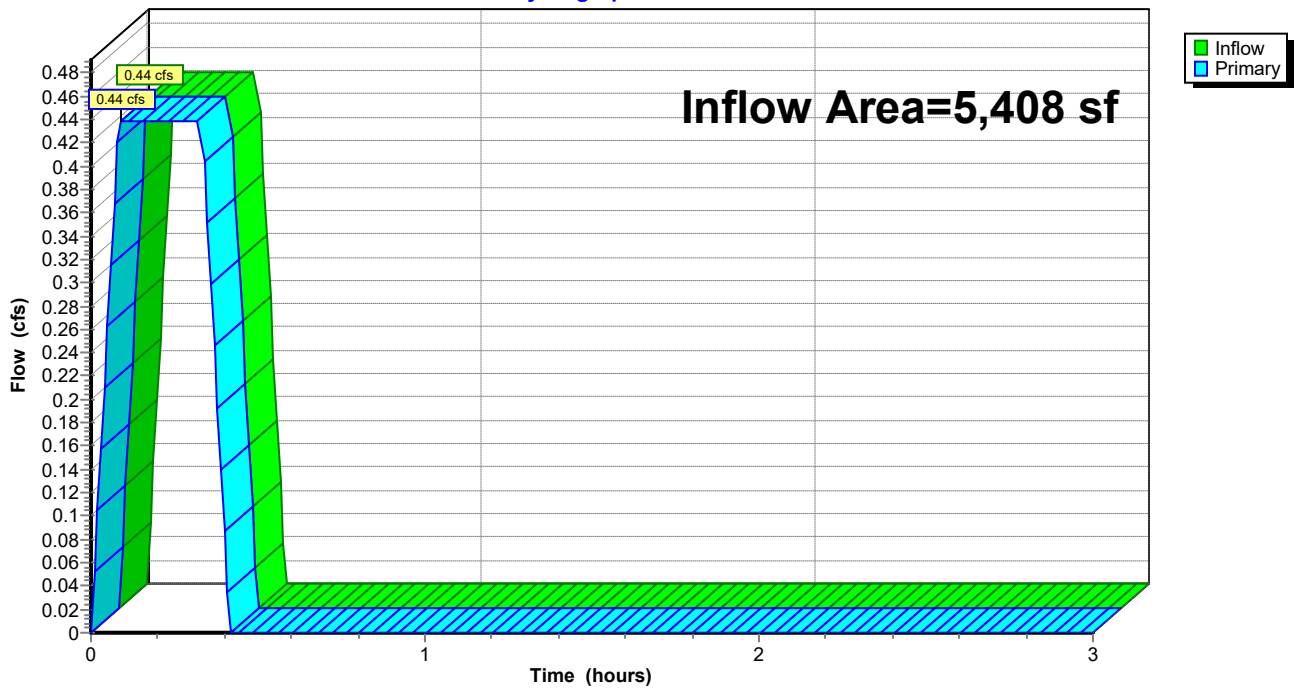

Summary for Pond CI-E2: CI - E2

Inflow Area = 11,591 sf, 64.62% Impervious, Inflow Depth = 1.06" for 10-yr event
Inflow = 0.86 cfs @ 0.09 hrs, Volume= 1,026 cf
Primary = 0.86 cfs @ 0.09 hrs, Volume= 1,026 cf, Atten= 0%, Lag= 0.0 min
Routed to Pond CI-C7 : CI - C7

Routing by Stor-Ind method, Time Span= 0.00-3.00 hrs, dt= 0.01 hrs

Pond CI-E2: CI - E2

Hydrograph

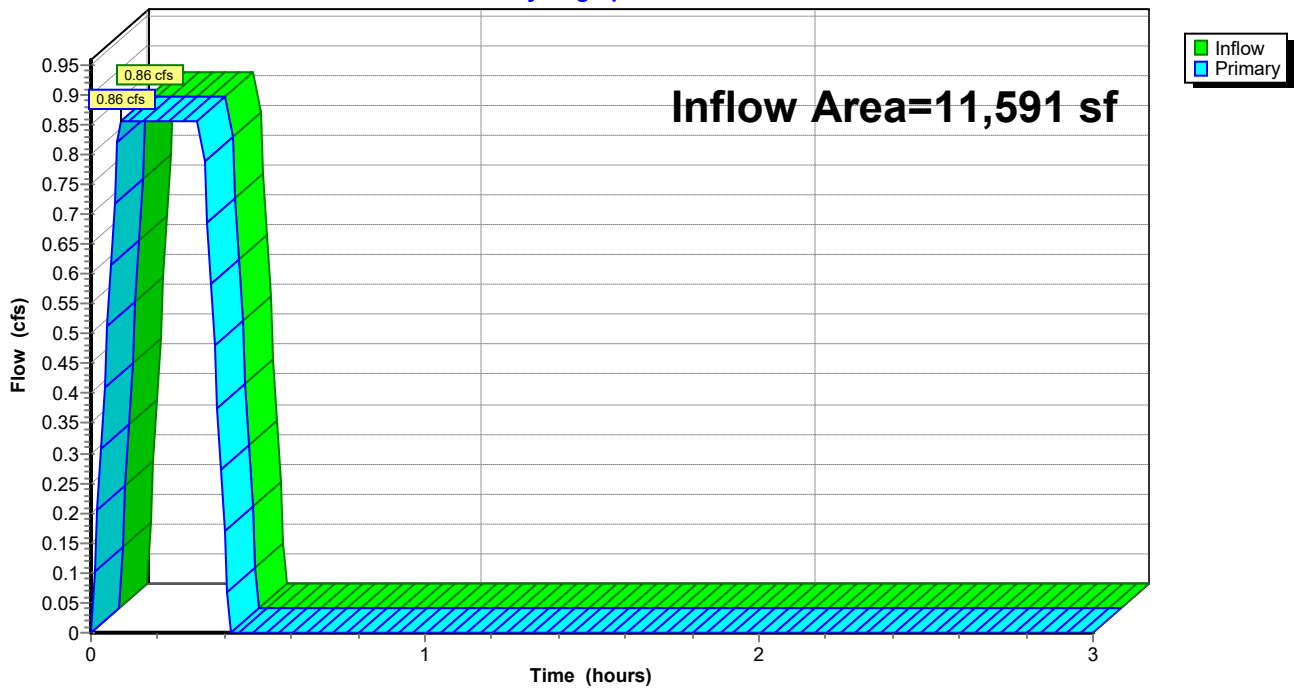

Goddard

Prepared by Phillip Lewis Engineering

HydroCAD® 10.20-5c s/n 12520 © 2023 HydroCAD Software Solutions LLC

AR - Little Rock 10-yr Duration=20 min, Inten=4.22 in/hr

Printed 3/25/2026

Summary for Pond DP: Existing North Detention Pond

Inflow Area = 322,783 sf, 53.09% Impervious, Inflow Depth = 0.99" for 10-yr event
 Inflow = 22.13 cfs @ 0.27 hrs, Volume= 26,552 cf
 Outflow = 10.48 cfs @ 0.39 hrs, Volume= 26,552 cf, Atten= 53%, Lag= 7.0 min
 Primary = 10.48 cfs @ 0.39 hrs, Volume= 26,552 cf
 Routed to Link FINAL : APPROX DISCHARGE

Routing by Stor-Ind method, Time Span= 0.00-3.00 hrs, dt= 0.01 hrs
 Peak Elev= 382.96' @ 0.39 hrs Storage= 15,778 cf

Plug-Flow detention time= 18.4 min calculated for 26,464 cf (100% of inflow)
 Center-of-Mass det. time= 18.5 min (32.0 - 13.5)

Volume	Invert	Avail.Storage	Storage Description
#1	381.17'	72,742 cf	Custom Stage Data Listed below

Elevation (feet)	Inc.Store (cubic-feet)	Cum.Store (cubic-feet)
381.17	0	0
381.50	200	200
382.00	1,825	2,025
382.50	5,265	7,290
383.00	9,300	16,590
383.50	13,733	30,323
384.00	18,578	48,901
384.50	23,841	72,742

Device	Routing	Invert	Outlet Devices
#1	Primary	384.16'	5.0' long Sharp-Crested Rectangular Weir 2 End Contraction(s)
#2	Primary	381.17'	1.7' long Sharp-Crested Rectangular Weir 2 End Contraction(s)

Primary OutFlow Max=10.48 cfs @ 0.39 hrs HW=382.96' (Free Discharge)

↑ **1=Sharp-Crested Rectangular Weir** (Controls 0.00 cfs)

└ **2=Sharp-Crested Rectangular Weir** (Weir Controls 10.48 cfs @ 4.37 fps)

Pond DP: Existing North Detention Pond

Hydrograph

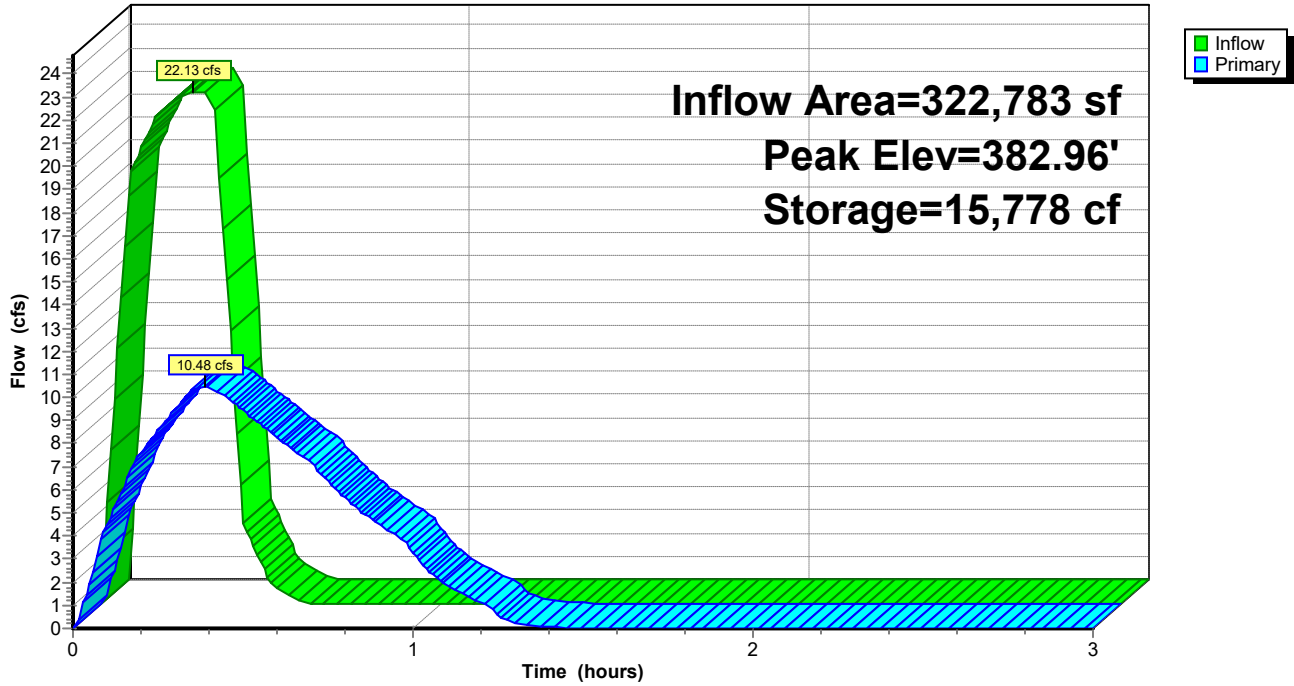

Summary for Pond JB-A2: JB - A2

Inflow Area = 50,937 sf, 59.76% Impervious, Inflow Depth = 1.09" for 10-yr event
Inflow = 3.85 cfs @ 0.17 hrs, Volume= 4,613 cf
Primary = 3.85 cfs @ 0.17 hrs, Volume= 4,613 cf, Atten= 0%, Lag= 0.0 min
Routed to Pond CI-A3 : CI - A3

Routing by Stor-Ind method, Time Span= 0.00-3.00 hrs, dt= 0.01 hrs

Pond JB-A2: JB - A2

Hydrograph

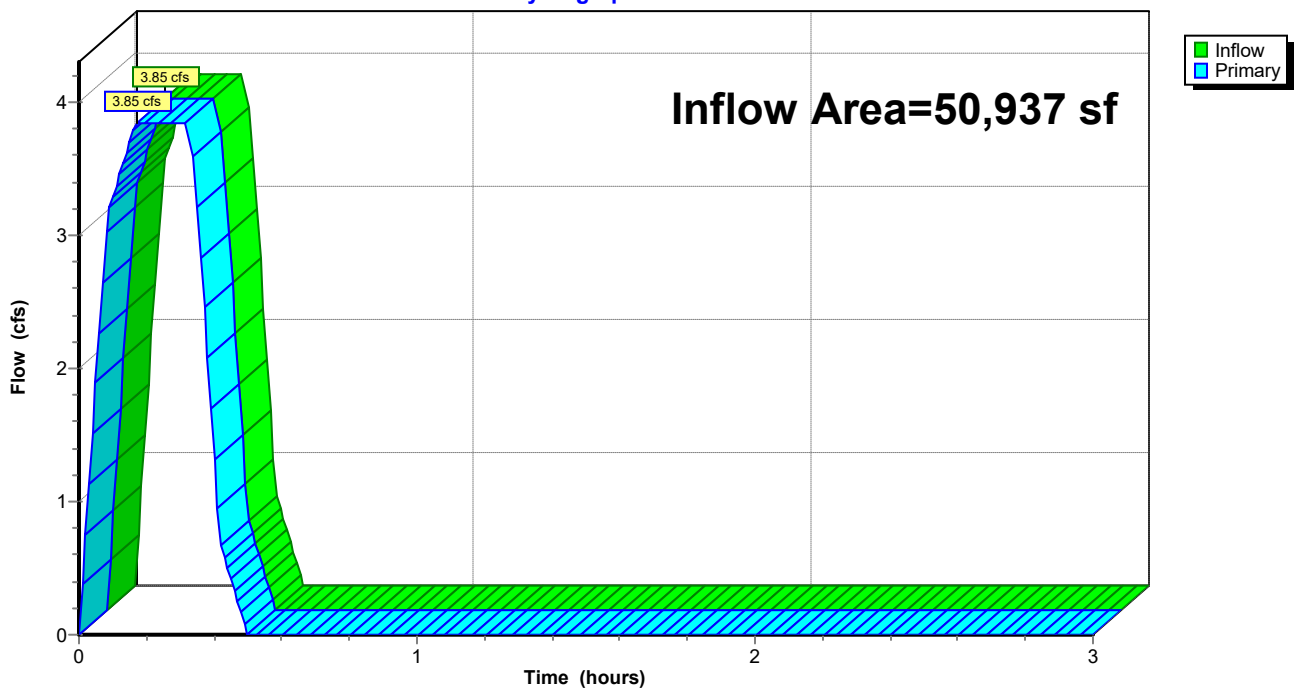

Summary for Link FINAL: APPROX DISCHARGE

Inflow Area = 509,184 sf, 38.62% Impervious, Inflow Depth = 0.90" for 10-yr event
Inflow = 19.81 cfs @ 0.33 hrs, Volume= 38,334 cf
Primary = 19.81 cfs @ 0.33 hrs, Volume= 38,334 cf, Atten= 0%, Lag= 0.0 min

Primary outflow = Inflow, Time Span= 0.00-3.00 hrs, dt= 0.01 hrs

Link FINAL: APPROX DISCHARGE

Hydrograph

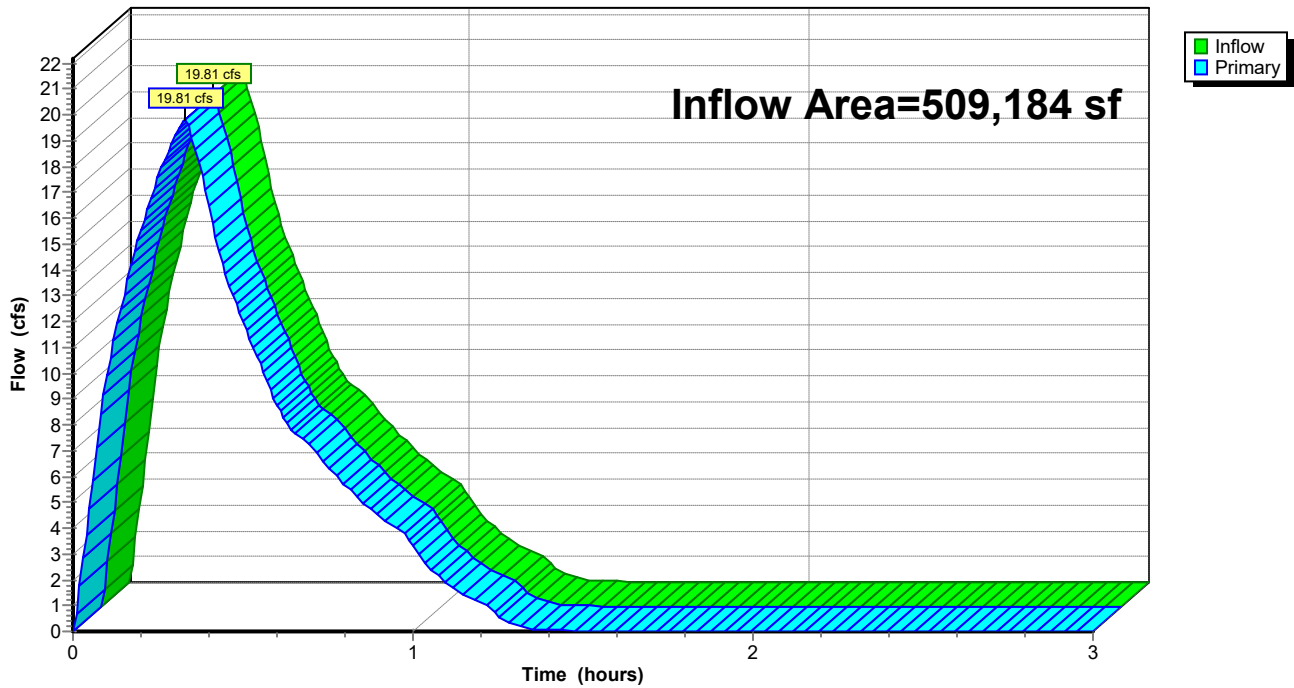

Goddard

Prepared by Phillip Lewis Engineering

HydroCAD® 10.20-5c s/n 12520 © 2023 HydroCAD Software Solutions LLC

AR - Little Rock 25-yr Duration=20 min, Inten=4.84 in/hr

Printed 3/25/2026

Summary for Subcatchment B1: Drainage Basin B1

Runoff = 4.44 cfs @ 0.31 hrs, Volume= 5,324 cf, Depth= 0.85"
 Routed to Link FINAL : APPROX DISCHARGE

Runoff by Rational method, Rise/Fall=1.0/1.0 xTc, Time Span= 0.00-3.00 hrs, dt= 0.01 hrs
 AR - Little Rock 25-yr Duration=20 min, Inten=4.84 in/hr

Area (sf)	C	Description
9,241	0.51	Sod Yard
602	0.95	Paving, Sidewalks
64,924	0.53	Undeveloped
74,767	0.53	Weighted Average
74,165		99.19% Pervious Area
602		0.81% Impervious Area

Tc (min)	Length (feet)	Slope (ft/ft)	Velocity (ft/sec)	Capacity (cfs)	Description
0.1	6	0.0180	0.86		Sheet Flow, Sheet Flow Smooth surfaces n= 0.011 P2= 4.19"
2.6	25	0.1920	0.16		Sheet Flow, Sheet Flow Grass: Bermuda n= 0.410 P2= 4.19"
11.9	75	0.0370	0.11		Sheet Flow, Sheet Flow Grass: Bermuda n= 0.410 P2= 4.19"
0.7	58	0.0370	1.35		Shallow Concentrated Flow, Concentrated Flow Short Grass Pasture Kv= 7.0 fps
1.6	141	0.0420	1.43		Shallow Concentrated Flow, Concentrated Flow Short Grass Pasture Kv= 7.0 fps
0.7	60	0.0400	1.40		Shallow Concentrated Flow, Concentrated Flow Short Grass Pasture Kv= 7.0 fps
0.9	77	0.0420	1.43		Shallow Concentrated Flow, Concentrated Flow Short Grass Pasture Kv= 7.0 fps
18.5	442	Total			

Subcatchment B1: Drainage Basin B1

Hydrograph

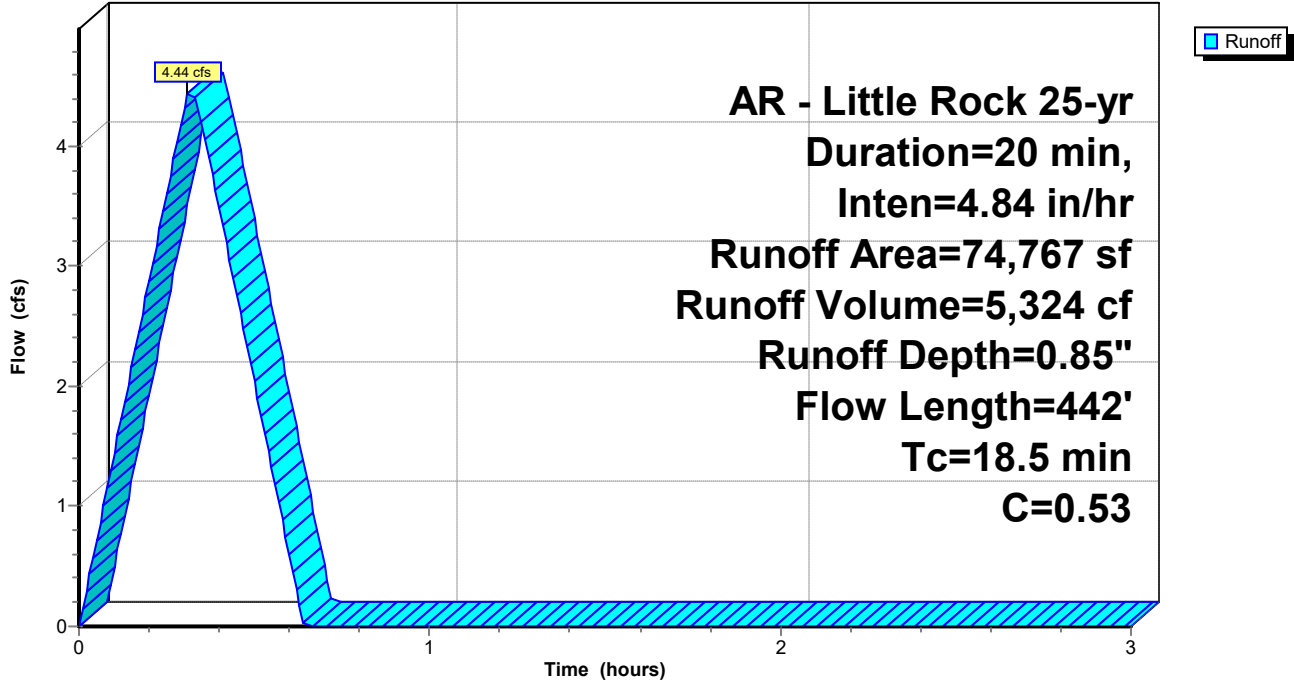

Goddard

Prepared by Phillip Lewis Engineering

HydroCAD® 10.20-5c s/n 12520 © 2023 HydroCAD Software Solutions LLC

AR - Little Rock 25-yr Duration=20 min, Inten=4.84 in/hr

Printed 3/25/2026

Summary for Subcatchment B2: Drainage Basin B2

Runoff = 0.39 cfs @ 0.10 hrs, Volume= 472 cf, Depth= 0.84"
Routed to Link FINAL : APPROX DISCHARGE

Runoff by Rational method, Rise/Fall=1.0/1.0 xTc, Time Span= 0.00-3.00 hrs, dt= 0.01 hrs
AR - Little Rock 25-yr Duration=20 min, Inten=4.84 in/hr

Area (sf)	C	Description
6,595	0.51	Sod Yard
167	0.95	Paving, Sidewalks
6,762	0.52	Weighted Average
6,595		97.53% Pervious Area
167		2.47% Impervious Area

Tc (min)	Length (feet)	Slope (ft/ft)	Velocity (ft/sec)	Capacity (cfs)	Description
0.1	6	0.0180	0.86		Sheet Flow, Sheet Flow Smooth surfaces n= 0.011 P2= 4.19"
5.7	55	0.1240	0.16		Sheet Flow, Sheet Flow Grass: Bermuda n= 0.410 P2= 4.19"
5.8	61	Total			

Subcatchment B2: Drainage Basin B2

Hydrograph

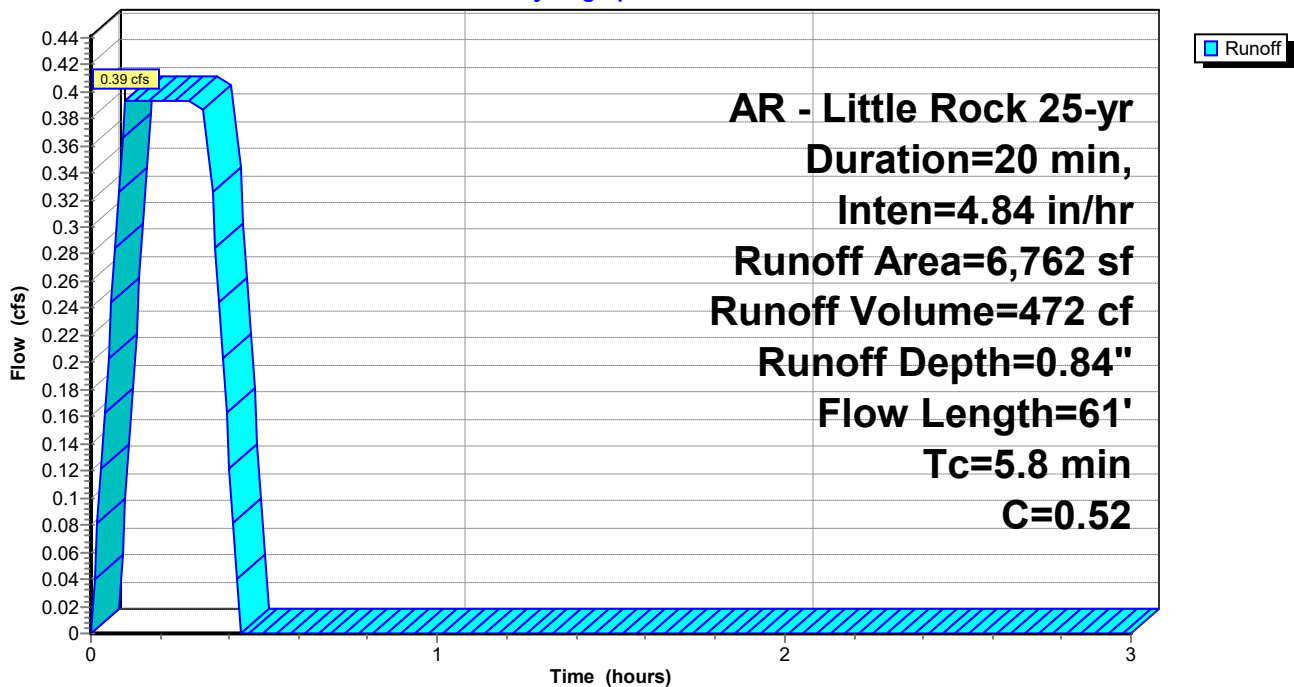

Goddard

Prepared by Phillip Lewis Engineering

HydroCAD® 10.20-5c s/n 12520 © 2023 HydroCAD Software Solutions LLC

AR - Little Rock 25-yr Duration=20 min, Inten=4.84 in/hr

Printed 3/25/2026

Summary for Subcatchment B3: Drainage Basin B3

Runoff = 2.61 cfs @ 0.26 hrs, Volume= 3,130 cf, Depth= 1.13"
 Routed to Link FINAL : APPROX DISCHARGE

Runoff by Rational method, Rise/Fall=1.0/1.0 xTc, Time Span= 0.00-3.00 hrs, dt= 0.01 hrs
 AR - Little Rock 25-yr Duration=20 min, Inten=4.84 in/hr

Area (sf)	C	Description
18,730	0.51	Sod Yard
14,559	0.95	Paving, Sidewalks
33,289	0.70	Weighted Average
18,730		56.26% Pervious Area
14,559		43.74% Impervious Area

Tc (min)	Length (feet)	Slope (ft/ft)	Velocity (ft/sec)	Capacity (cfs)	Description
4.9	47	0.1300	0.16		Sheet Flow, Sheet Flow Grass: Bermuda n= 0.410 P2= 4.19"
6.9	53	0.0730	0.13		Sheet Flow, Sheet Flow Grass: Bermuda n= 0.410 P2= 4.19"
0.0	11	0.0940	4.60		Shallow Concentrated Flow, Concentrated Flow Grassed Waterway Kv= 15.0 fps
0.4	53	0.0120	2.22		Shallow Concentrated Flow, Concentrated Flow Paved Kv= 20.3 fps
0.5	59	0.0100	2.03		Shallow Concentrated Flow, Concentrated Flow Paved Kv= 20.3 fps
0.5	47	0.0070	1.70		Shallow Concentrated Flow, Concentrated Flow Paved Kv= 20.3 fps
0.5	56	0.0070	1.70		Shallow Concentrated Flow, Concentrated Flow Paved Kv= 20.3 fps
0.2	38	0.0160	2.57		Shallow Concentrated Flow, Concentrated Flow Paved Kv= 20.3 fps
0.2	30	0.0190	2.80		Shallow Concentrated Flow, Concentrated Flow Paved Kv= 20.3 fps
1.3	216	0.0190	2.80		Shallow Concentrated Flow, Concentrated Flow Paved Kv= 20.3 fps
15.4	610	Total			

Subcatchment B3: Drainage Basin B3

Hydrograph

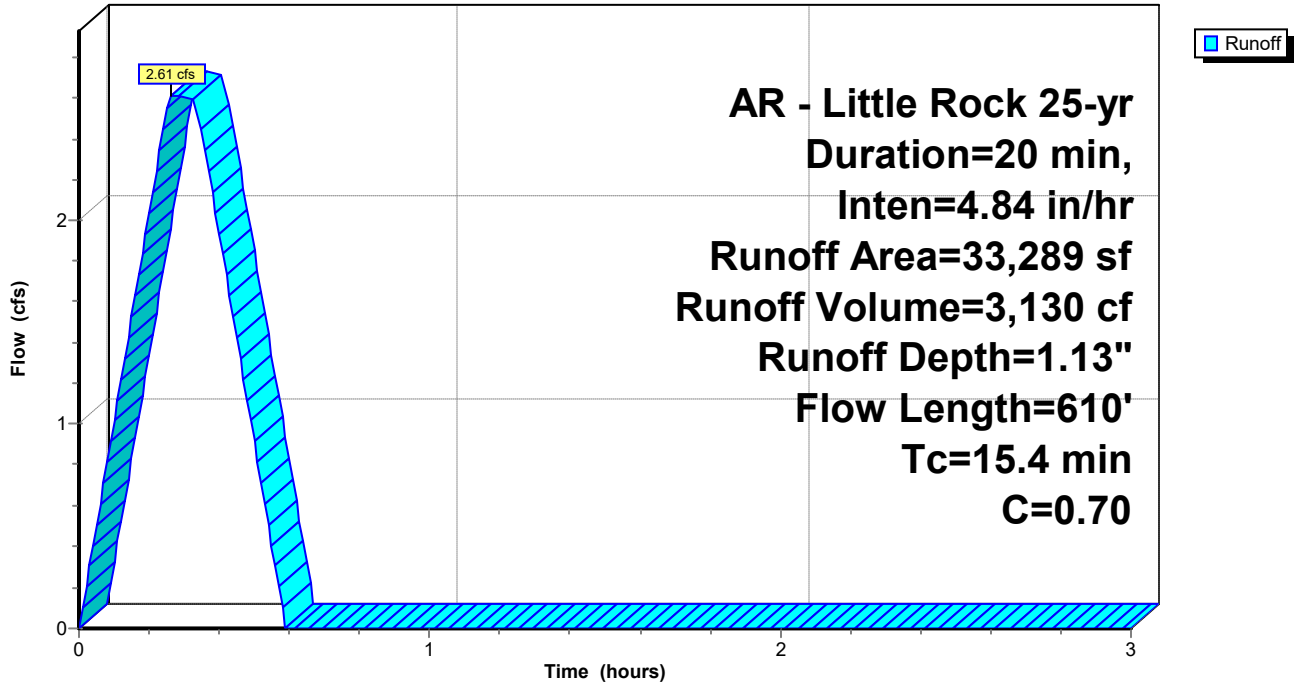

Goddard

Prepared by Phillip Lewis Engineering

HydroCAD® 10.20-5c s/n 12520 © 2023 HydroCAD Software Solutions LLC

AR - Little Rock 25-yr Duration=20 min, Inten=4.84 in/hr

Printed 3/25/2026

Summary for Subcatchment B4: Drainage Basin B4

Runoff = 1.83 cfs @ 0.09 hrs, Volume= 2,199 cf, Depth= 1.35"
 Routed to Pond CI-A1 : CI - A1

Runoff by Rational method, Rise/Fall=1.0/1.0 xTc, Time Span= 0.00-3.00 hrs, dt= 0.01 hrs
 AR - Little Rock 25-yr Duration=20 min, Inten=4.84 in/hr

Area (sf)	C	Description
4,916	0.51	Sod Yard
14,577	0.95	Paving, Sidewalks
19,493	0.84	Weighted Average
4,916		25.22% Pervious Area
14,577		74.78% Impervious Area

Tc (min)	Length (feet)	Slope (ft/ft)	Velocity (ft/sec)	Capacity (cfs)	Description
0.4	31	0.0230	1.32		Sheet Flow, Sheet Flow Smooth surfaces n= 0.011 P2= 4.19"
0.2	18	0.0250	1.22		Sheet Flow, Sheet Flow Smooth surfaces n= 0.011 P2= 4.19"
0.3	28	0.0450	1.69		Sheet Flow, Sheet Flow Smooth surfaces n= 0.011 P2= 4.19"
0.4	72	0.0250	3.21		Shallow Concentrated Flow, Concentrated Flow Paved Kv= 20.3 fps
0.1	18	0.0170	2.65		Shallow Concentrated Flow, Concentrated Flow Paved Kv= 20.3 fps
0.3	51	0.0170	2.65		Shallow Concentrated Flow, Concentrated Flow Paved Kv= 20.3 fps
0.1	16	0.0170	2.65		Shallow Concentrated Flow, Concentrated Flow Paved Kv= 20.3 fps
0.0	8	0.0430	4.21		Shallow Concentrated Flow, Concentrated Flow Paved Kv= 20.3 fps
0.0	7	0.0580	4.89		Shallow Concentrated Flow, Concentrated Flow Paved Kv= 20.3 fps
3.2					Direct Entry, Overland Concentrated Flow (Min)
5.0	249	Total			

Subcatchment B4: Drainage Basin B4

Hydrograph

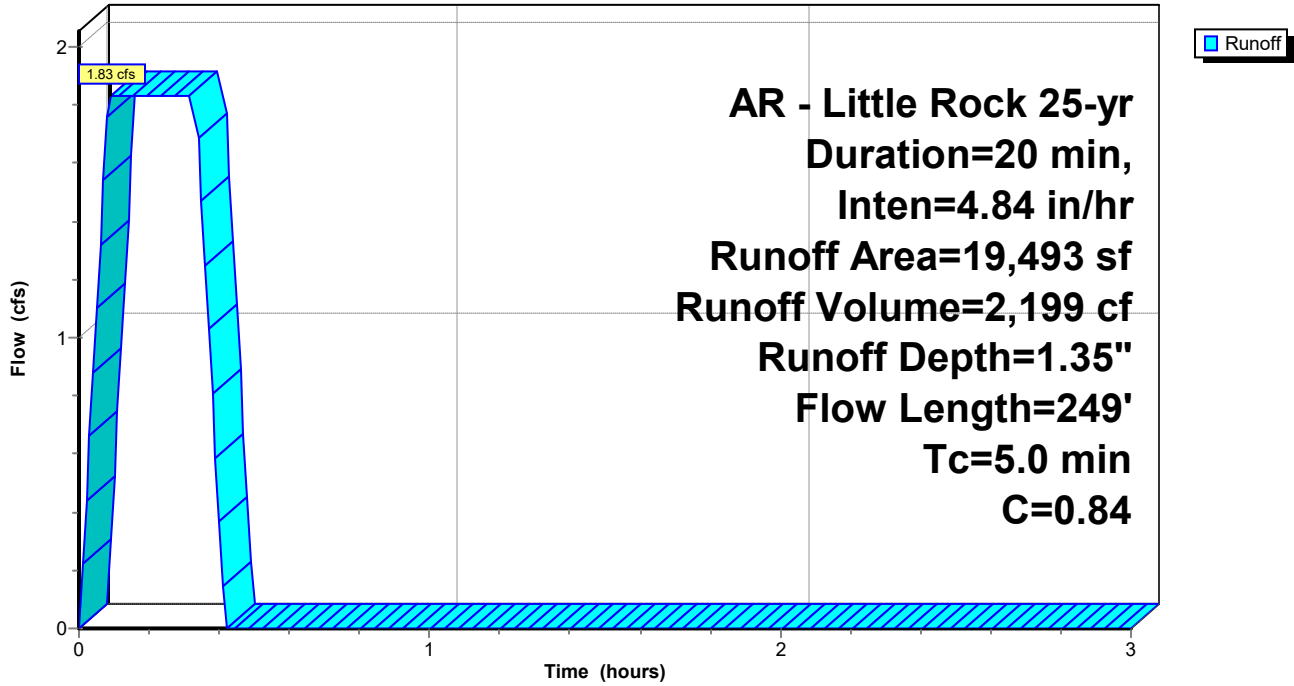

Summary for Subcatchment B5: Drainage Basin B5

Runoff = 0.99 cfs @ 0.09 hrs, Volume= 1,184 cf, Depth= 1.53"
 Routed to Pond JB-A2 : JB - A2

Runoff by Rational method, Rise/Fall=1.0/1.0 xTc, Time Span= 0.00-3.00 hrs, dt= 0.01 hrs
 AR - Little Rock 25-yr Duration=20 min, Inten=4.84 in/hr

Area (sf)	C	Description
9,275	0.95	Roof
9,275		100.00% Impervious Area

Tc (min)	Length (feet)	Slope (ft/ft)	Velocity (ft/sec)	Capacity (cfs)	Description
5.0					Direct Entry, Concentrated Flow (Min)

Subcatchment B5: Drainage Basin B5

Hydrograph

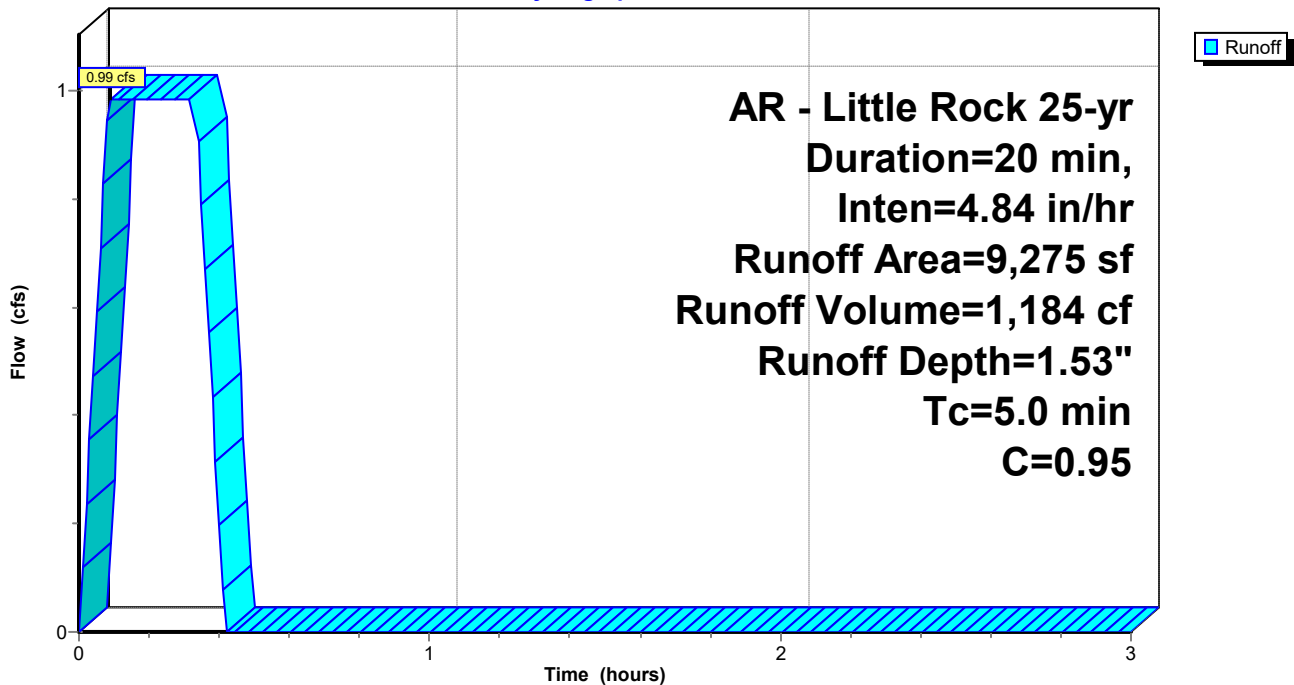

Goddard

Prepared by Phillip Lewis Engineering

HydroCAD® 10.20-5c s/n 12520 © 2023 HydroCAD Software Solutions LLC

AR - Little Rock 25-yr Duration=20 min, Inten=4.84 in/hr

Printed 3/25/2026

Summary for Subcatchment B6: Drainage Basin B6

Runoff = 0.20 cfs @ 0.09 hrs, Volume= 241 cf, Depth= 1.53"
 Routed to Pond CI-A3 : CI - A3

Runoff by Rational method, Rise/Fall=1.0/1.0 xTc, Time Span= 0.00-3.00 hrs, dt= 0.01 hrs
 AR - Little Rock 25-yr Duration=20 min, Inten=4.84 in/hr

Area (sf)	C	Description
0	0.51	Sod Yard
1,887	0.95	Paving, Sidewalks
1,887	0.95	Weighted Average
1,887		100.00% Impervious Area

Tc (min)	Length (feet)	Slope (ft/ft)	Velocity (ft/sec)	Capacity (cfs)	Description
0.4	31	0.0230	1.32		Sheet Flow, Sheet Flow Smooth surfaces n= 0.011 P2= 4.19"
0.2	18	0.0250	1.22		Sheet Flow, Sheet Flow Smooth surfaces n= 0.011 P2= 4.19"
0.4	30	0.0240	1.33		Sheet Flow, Sheet Flow Smooth surfaces n= 0.011 P2= 4.19"
0.0	13	0.0860	5.95		Shallow Concentrated Flow, Concentrated Flow Paved Kv= 20.3 fps
4.0	415		1.73		Direct Entry, Overland Concentrated Flow (Min)
5.0	507	Total			

Subcatchment B6: Drainage Basin B6

Hydrograph

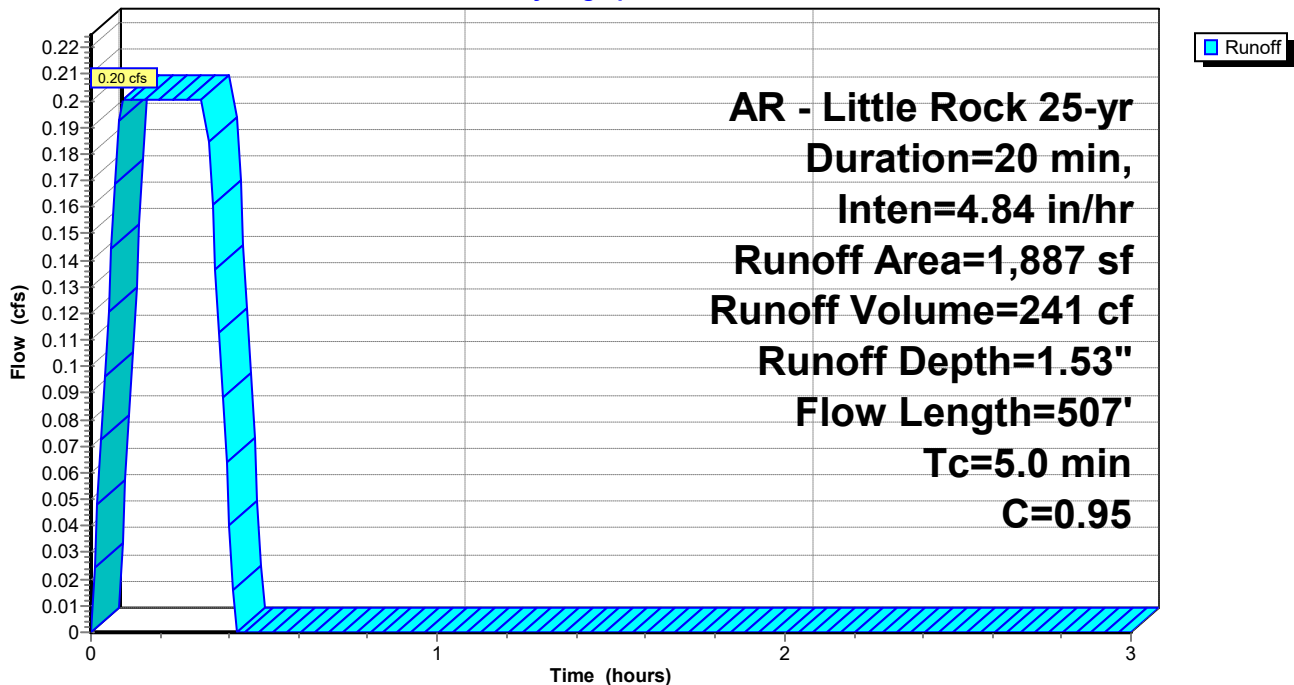

Goddard

Prepared by Phillip Lewis Engineering

HydroCAD® 10.20-5c s/n 12520 © 2023 HydroCAD Software Solutions LLC

AR - Little Rock 25-yr Duration=20 min, Inten=4.84 in/hr

Printed 3/25/2026

Summary for Subcatchment B7: Drainage Basin B7

Runoff = 1.59 cfs @ 0.17 hrs, Volume= 1,906 cf, Depth= 1.03"
 Routed to Pond CI-B2 : CI - B2

Runoff by Rational method, Rise/Fall=1.0/1.0 xTc, Time Span= 0.00-3.00 hrs, dt= 0.01 hrs
 AR - Little Rock 25-yr Duration=20 min, Inten=4.84 in/hr

Area (sf)	C	Description
15,580	0.51	Sod Yard
6,589	0.95	Paving, Sidewalks
22,169	0.64	Weighted Average
15,580		70.28% Pervious Area
6,589		29.72% Impervious Area

Tc (min)	Length (feet)	Slope (ft/ft)	Velocity (ft/sec)	Capacity (cfs)	Description
0.2	10	0.0150	0.89		Sheet Flow, Sheet Flow Smooth surfaces n= 0.011 P2= 4.19"
9.1	93	0.0150	0.17		Sheet Flow, Sheet Flow Grass: Short n= 0.150 P2= 4.19"
0.4	40	0.0110	1.57		Shallow Concentrated Flow, Concentrated Flow Grassed Waterway Kv= 15.0 fps
0.3	33	0.0190	2.07		Shallow Concentrated Flow, Concentrated Flow Grassed Waterway Kv= 15.0 fps
0.0	6	0.0180	2.72		Shallow Concentrated Flow, Concentrated Flow Paved Kv= 20.3 fps
10.0	182	Total			

Subcatchment B7: Drainage Basin B7

Hydrograph

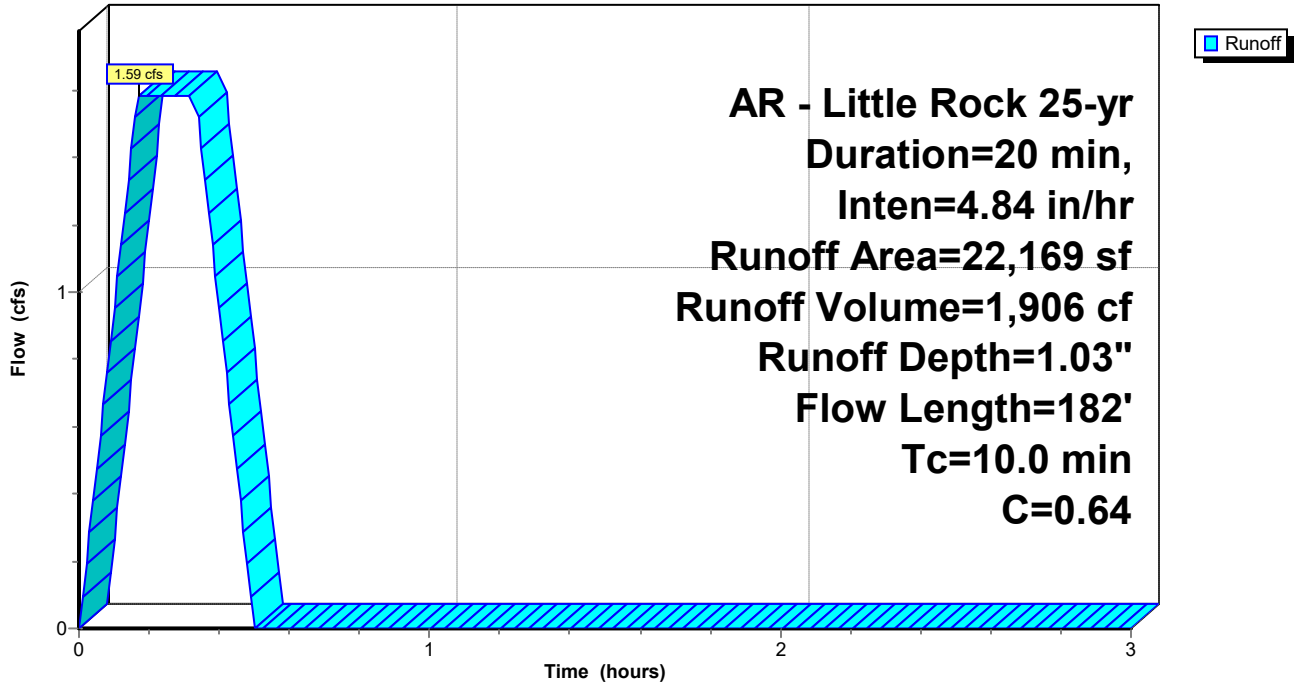

Goddard

Prepared by Phillip Lewis Engineering

HydroCAD® 10.20-5c s/n 12520 © 2023 HydroCAD Software Solutions LLC

AR - Little Rock 25-yr Duration=20 min, Inten=4.84 in/hr

Printed 3/25/2026

Summary for Subcatchment B8: Drainage Basin B8

Runoff = 1.15 cfs @ 0.24 hrs, Volume= 1,377 cf, Depth= 1.14"
 Routed to Pond CI-A4 : CI - A4

Runoff by Rational method, Rise/Fall=1.0/1.0 xTc, Time Span= 0.00-3.00 hrs, dt= 0.01 hrs
 AR - Little Rock 25-yr Duration=20 min, Inten=4.84 in/hr

Area (sf)	C	Description
7,982	0.51	Sod Yard
6,458	0.95	Paving, Sidewalks
14,440	0.71	Weighted Average
7,982		55.28% Pervious Area
6,458		44.72% Impervious Area

Tc (min)	Length (feet)	Slope (ft/ft)	Velocity (ft/sec)	Capacity (cfs)	Description
10.4	79	0.0570	0.13		Sheet Flow, Sheet Flow Grass: Bermuda n= 0.410 P2= 4.19"
3.5	21	0.0620	0.10		Sheet Flow, Sheet Flow Grass: Bermuda n= 0.410 P2= 4.19"
0.0	9	0.0620	3.73		Shallow Concentrated Flow, Concentrated Flow Grassed Waterway Kv= 15.0 fps
0.1	18	0.1080	4.93		Shallow Concentrated Flow, Concentrated Flow Grassed Waterway Kv= 15.0 fps
14.0	127	Total			

Subcatchment B8: Drainage Basin B8

Hydrograph

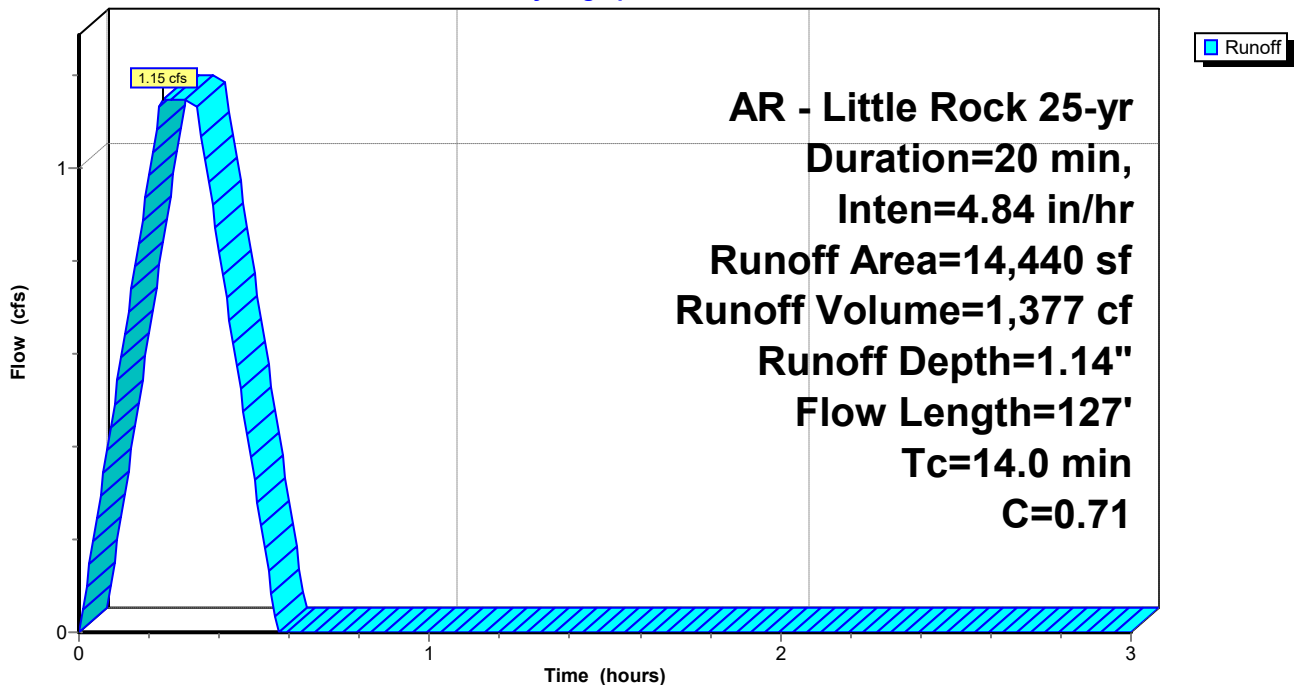

Goddard

Prepared by Phillip Lewis Engineering

HydroCAD® 10.20-5c s/n 12520 © 2023 HydroCAD Software Solutions LLC

AR - Little Rock 25-yr Duration=20 min, Inten=4.84 in/hr

Printed 3/25/2026

Summary for Subcatchment C1: Drainage Basin C1

Runoff = 1.78 cfs @ 0.09 hrs, Volume= 2,130 cf, Depth= 1.26"
 Routed to Pond CI-C1 : CI - C1

Runoff by Rational method, Rise/Fall=1.0/1.0 xTc, Time Span= 0.00-3.00 hrs, dt= 0.01 hrs
 AR - Little Rock 25-yr Duration=20 min, Inten=4.84 in/hr

Area (sf)	C	Description
6,135	0.40	Sod Yard
14,202	0.95	Paving, Sidewalks
20,337	0.78	Weighted Average
6,135		30.17% Pervious Area
14,202		69.83% Impervious Area

Tc (min)	Length (feet)	Slope (ft/ft)	Velocity (ft/sec)	Capacity (cfs)	Description
4.8	32	0.0660	0.11		Sheet Flow, Sheet Flow Grass: Bermuda n= 0.410 P2= 4.19"
0.4	102	0.0470	4.40		Shallow Concentrated Flow, Concentrated Flow Paved Kv= 20.3 fps
5.2	134	Total			

Subcatchment C1: Drainage Basin C1

Hydrograph

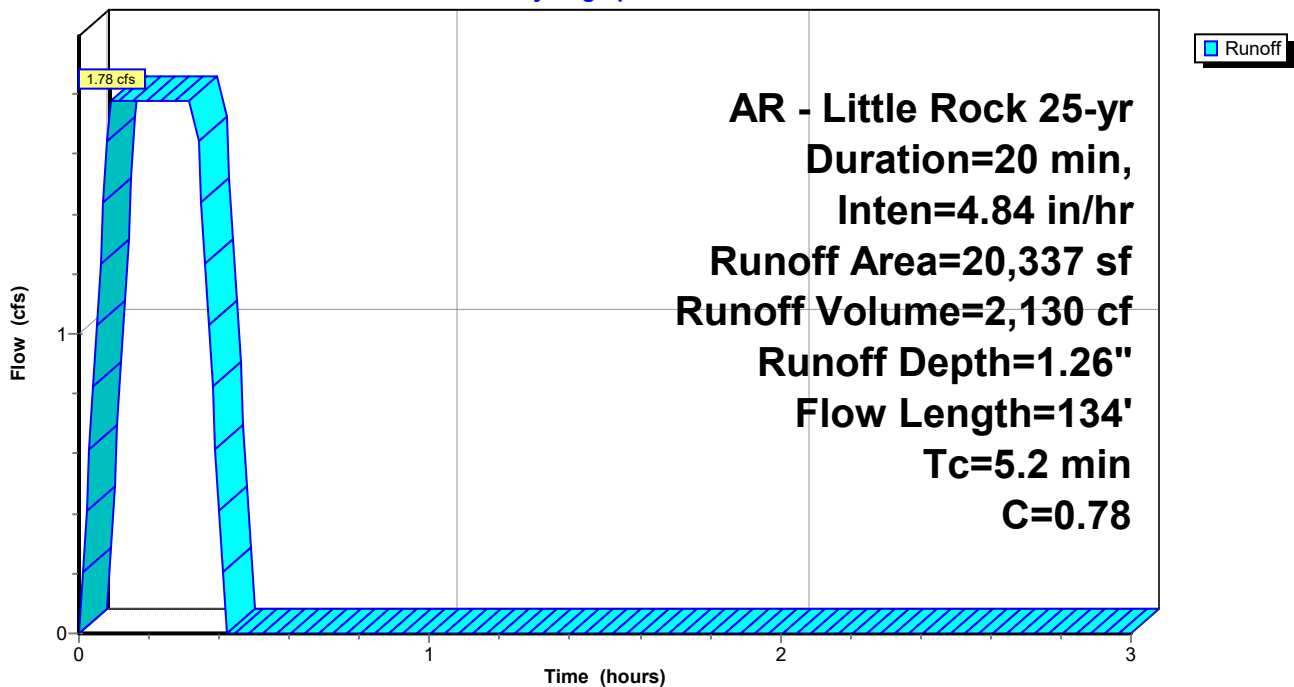

Goddard

Prepared by Phillip Lewis Engineering

HydroCAD® 10.20-5c s/n 12520 © 2023 HydroCAD Software Solutions LLC

AR - Little Rock 25-yr Duration=20 min, Inten=4.84 in/hr

Printed 3/25/2026

Summary for Subcatchment C10: Drainage Basin C10

Runoff = 0.50 cfs @ 0.09 hrs, Volume= 603 cf, Depth= 1.34"
 Routed to Pond CI-E1 : CI - E1

Runoff by Rational method, Rise/Fall=1.0/1.0 xTc, Time Span= 0.00-3.00 hrs, dt= 0.01 hrs
 AR - Little Rock 25-yr Duration=20 min, Inten=4.84 in/hr

Area (sf)	C	Description
1,225	0.40	Sod Yard
4,183	0.95	Paving, Sidewalks
5,408	0.83	Weighted Average
1,225		22.65% Pervious Area
4,183		77.35% Impervious Area

Tc (min)	Length (feet)	Slope (ft/ft)	Velocity (ft/sec)	Capacity (cfs)	Description
0.3	18	0.0200	1.12		Sheet Flow, Sheet Flow Smooth surfaces n= 0.011 P2= 4.19"
0.2	29	0.0210	2.94		Shallow Concentrated Flow, Concentrated Flow Paved Kv= 20.3 fps
0.1	23	0.0320	3.63		Shallow Concentrated Flow, Concentrated Flow Paved Kv= 20.3 fps
0.2	36	0.0320	3.63		Shallow Concentrated Flow, Concentrated Flow Paved Kv= 20.3 fps
0.2	48	0.0330	3.69		Shallow Concentrated Flow, Concentrated Flow Paved Kv= 20.3 fps
0.1	13	0.0350	3.80		Shallow Concentrated Flow, Concentrated Flow Paved Kv= 20.3 fps
3.9	415		1.77		Direct Entry, Concentrated Flow (Min)
5.0	582	Total			

Subcatchment C10: Drainage Basin C10

Hydrograph

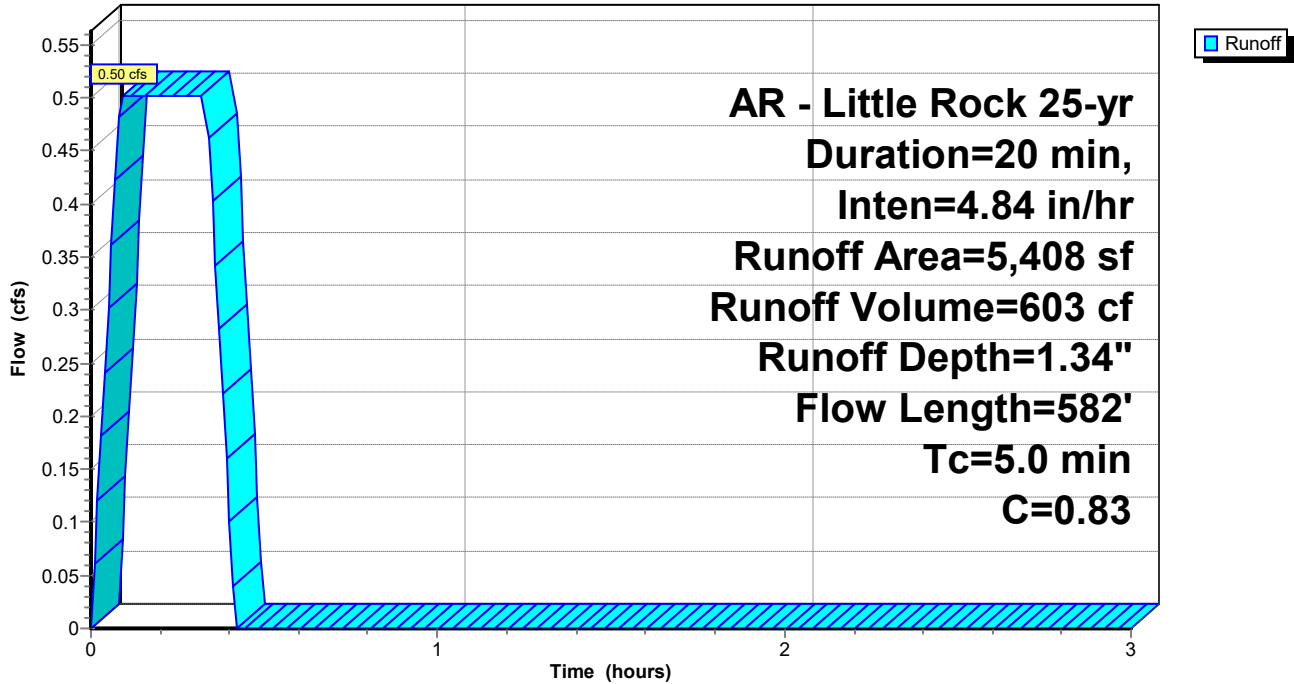

Goddard

Prepared by Phillip Lewis Engineering

HydroCAD® 10.20-5c s/n 12520 © 2023 HydroCAD Software Solutions LLC

AR - Little Rock 25-yr Duration=20 min, Inten=4.84 in/hr

Printed 3/25/2026

Summary for Subcatchment C11: Drainage Basin C11

Runoff = 0.48 cfs @ 0.09 hrs, Volume= 573 cf, Depth= 1.11"
 Routed to Pond CI-E2 : CI - E2

Runoff by Rational method, Rise/Fall=1.0/1.0 xTc, Time Span= 0.00-3.00 hrs, dt= 0.01 hrs
 AR - Little Rock 25-yr Duration=20 min, Inten=4.84 in/hr

Area (sf)	C	Description
2,876	0.40	Sod Yard
3,307	0.95	Paving, Sidewalks
6,183	0.69	Weighted Average
2,876		46.51% Pervious Area
3,307		53.49% Impervious Area

Tc (min)	Length (feet)	Slope (ft/ft)	Velocity (ft/sec)	Capacity (cfs)	Description
0.3	25	0.0200	1.19		Sheet Flow, Sheet Flow Smooth surfaces n= 0.011 P2= 4.19"
0.1	33	0.0620	5.05		Shallow Concentrated Flow, Concentrated Flow Paved Kv= 20.3 fps
0.1	29	0.0540	4.72		Shallow Concentrated Flow, Concentrated Flow Paved Kv= 20.3 fps
0.2	47	0.0410	4.11		Shallow Concentrated Flow, Concentrated Flow Paved Kv= 20.3 fps
0.2	47	0.0390	4.01		Shallow Concentrated Flow, Concentrated Flow Paved Kv= 20.3 fps
0.1	37	0.0420	4.16		Shallow Concentrated Flow, Concentrated Flow Paved Kv= 20.3 fps
4.0	415		1.73		Direct Entry, Concentrated Flow (Min)
5.0	633	Total			

Subcatchment C11: Drainage Basin C11

Hydrograph

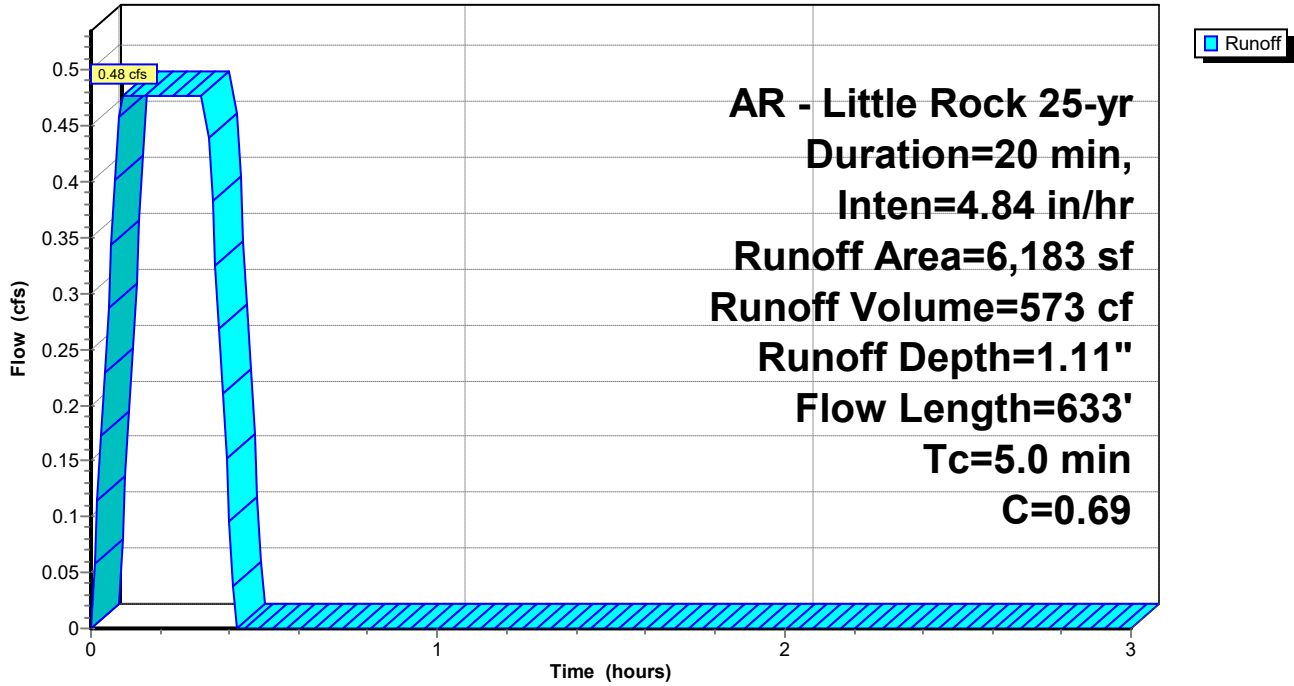

Goddard

Prepared by Phillip Lewis Engineering

HydroCAD® 10.20-5c s/n 12520 © 2023 HydroCAD Software Solutions LLC

AR - Little Rock 25-yr Duration=20 min, Inten=4.84 in/hr

Printed 3/25/2026

Summary for Subcatchment C12: Drainage Basin C12

Runoff = 2.30 cfs @ 0.09 hrs, Volume= 2,757 cf, Depth= 1.29"
 Routed to Pond CI-C7 : CI - C7

Runoff by Rational method, Rise/Fall=1.0/1.0 xTc, Time Span= 0.00-3.00 hrs, dt= 0.01 hrs
 AR - Little Rock 25-yr Duration=20 min, Inten=4.84 in/hr

Area (sf)	C	Description
7,218	0.40	Sod Yard
18,440	0.95	Paving, Sidewalks
25,658	0.80	Weighted Average
7,218		28.13% Pervious Area
18,440		71.87% Impervious Area

Tc (min)	Length (feet)	Slope (ft/ft)	Velocity (ft/sec)	Capacity (cfs)	Description
0.3	24	0.0360	1.50		Sheet Flow, Sheet Flow Smooth surfaces n= 0.011 P2= 4.19"
0.1	5	0.0190	0.85		Sheet Flow, Sheet Flow Smooth surfaces n= 0.011 P2= 4.19"
0.2	21	0.0100	2.03		Shallow Concentrated Flow, Concentrated Flow Paved Kv= 20.3 fps
0.9	49	0.0020	0.91		Shallow Concentrated Flow, Concentrated Flow Paved Kv= 20.3 fps
0.4	96	0.0330	3.69		Shallow Concentrated Flow, Concentrated Flow Paved Kv= 20.3 fps
0.3	94	0.0570	4.85		Shallow Concentrated Flow, Concentrated Flow Paved Kv= 20.3 fps
0.1	28	0.0560	4.80		Shallow Concentrated Flow, Concentrated Flow Paved Kv= 20.3 fps
0.1	25	0.0450	4.31		Shallow Concentrated Flow, Concentrated Flow Paved Kv= 20.3 fps
0.1	31	0.0410	4.11		Shallow Concentrated Flow, Concentrated Flow Paved Kv= 20.3 fps
0.1	39	0.0490	4.49		Shallow Concentrated Flow, Concentrated Flow Paved Kv= 20.3 fps
0.1	36	0.0460	4.35		Shallow Concentrated Flow, Concentrated Flow Paved Kv= 20.3 fps
0.0	11	0.0470	4.40		Shallow Concentrated Flow, Concentrated Flow Paved Kv= 20.3 fps
0.0	6	0.0440	4.26		Shallow Concentrated Flow, Concentrated Flow Paved Kv= 20.3 fps
2.3	415		3.01		Direct Entry, Concentrated Flow (Min)
5.0	880	Total			

Subcatchment C12: Drainage Basin C12

Hydrograph

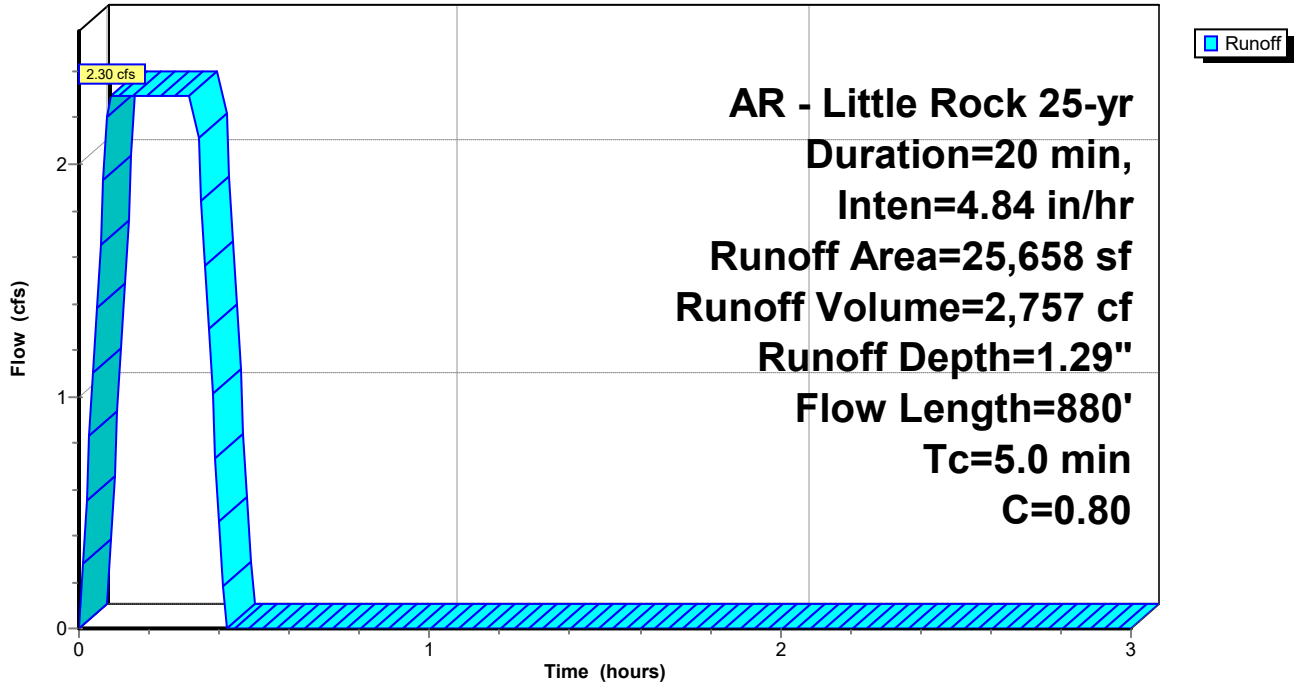

Goddard

Prepared by Phillip Lewis Engineering

HydroCAD® 10.20-5c s/n 12520 © 2023 HydroCAD Software Solutions LLC

AR - Little Rock 25-yr Duration=20 min, Inten=4.84 in/hr

Printed 3/25/2026

Summary for Subcatchment C13: Drainage Basin C13

Runoff = 0.75 cfs @ 0.09 hrs, Volume= 897 cf, Depth= 1.35"
 Routed to Pond CI-A4 : CI - A4

Runoff by Rational method, Rise/Fall=1.0/1.0 xTc, Time Span= 0.00-3.00 hrs, dt= 0.01 hrs
 AR - Little Rock 25-yr Duration=20 min, Inten=4.84 in/hr

Area (sf)	C	Description
1,558	0.40	Sod Yard
6,388	0.95	Paving, Sidewalks
7,946	0.84	Weighted Average
1,558		19.61% Pervious Area
6,388		80.39% Impervious Area

Tc (min)	Length (feet)	Slope (ft/ft)	Velocity (ft/sec)	Capacity (cfs)	Description
0.3	19	0.0200	1.13		Sheet Flow, Sheet Flow Smooth surfaces n= 0.011 P2= 4.19"
0.3	75	0.0340	3.74		Shallow Concentrated Flow, Concentrated Flow Paved Kv= 20.3 fps
0.2	52	0.0410	4.11		Shallow Concentrated Flow, Concentrated Flow Paved Kv= 20.3 fps
0.1	29	0.0470	4.40		Shallow Concentrated Flow, Concentrated Flow Paved Kv= 20.3 fps
0.1	42	0.0730	5.48		Shallow Concentrated Flow, Concentrated Flow Paved Kv= 20.3 fps
0.2	74	0.0750	5.56		Shallow Concentrated Flow, Concentrated Flow Paved Kv= 20.3 fps
0.1	26	0.0710	5.41		Shallow Concentrated Flow, Concentrated Flow Paved Kv= 20.3 fps
0.1	32	0.0570	4.85		Shallow Concentrated Flow, Concentrated Flow Paved Kv= 20.3 fps
0.0	13	0.0470	4.40		Shallow Concentrated Flow, Concentrated Flow Paved Kv= 20.3 fps
3.6	415		1.92		Direct Entry, Overland Concentrated Flow (Min)
5.0	777	Total			

Subcatchment C13: Drainage Basin C13

Hydrograph

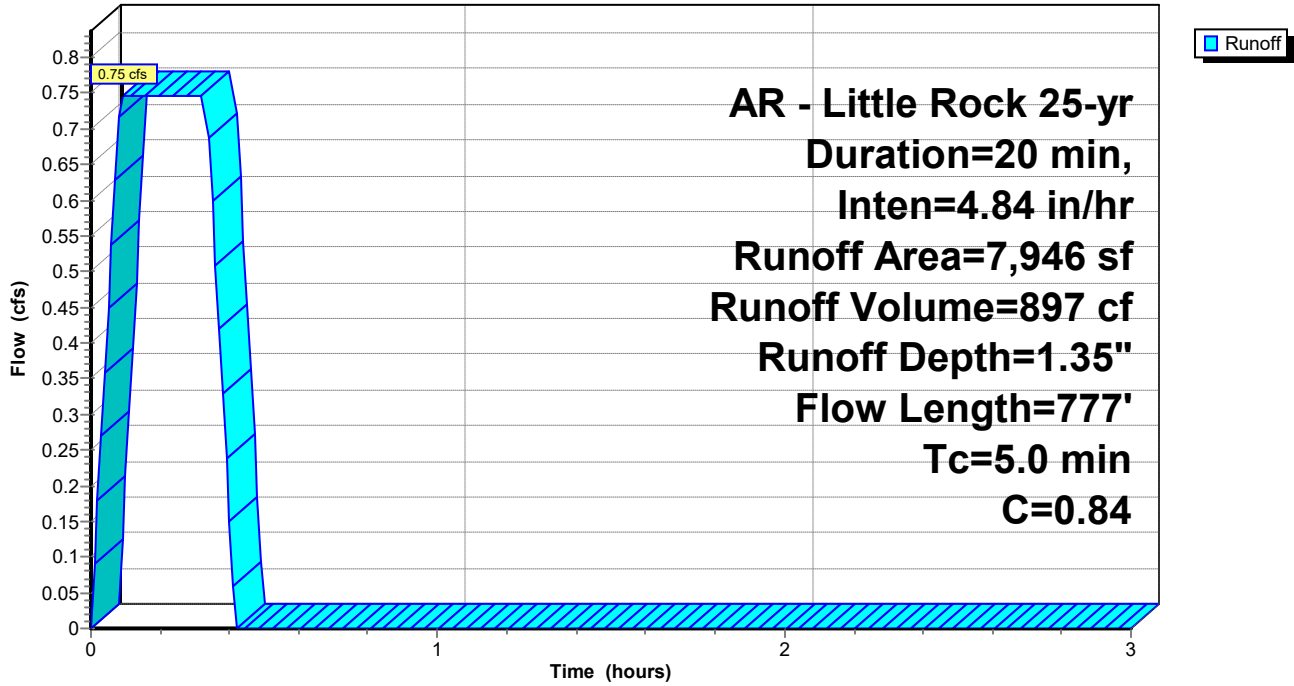

Goddard

Prepared by Phillip Lewis Engineering

HydroCAD® 10.20-5c s/n 12520 © 2023 HydroCAD Software Solutions LLC

AR - Little Rock 25-yr Duration=20 min, Inten=4.84 in/hr

Printed 3/25/2026

Summary for Subcatchment C14: Drainage Basin C14

Runoff = 1.97 cfs @ 0.27 hrs, Volume= 2,367 cf, Depth= 1.29"
 Routed to Pond CI-A5 : CI - A5

Runoff by Rational method, Rise/Fall=1.0/1.0 xTc, Time Span= 0.00-3.00 hrs, dt= 0.01 hrs
 AR - Little Rock 25-yr Duration=20 min, Inten=4.84 in/hr

Area (sf)	C	Description
6,127	0.40	Sod Yard
15,898	0.95	Paving, Sidewalks
22,025	0.80	Weighted Average
6,127		27.82% Pervious Area
15,898		72.18% Impervious Area

Tc (min)	Length (feet)	Slope (ft/ft)	Velocity (ft/sec)	Capacity (cfs)	Description
1.5	5	0.0310	0.06		Sheet Flow, Sheet Flow
					Grass: Bermuda n= 0.410 P2= 4.19"
9.2	45	0.0250	0.08		Sheet Flow, Sheet Flow
					Grass: Bermuda n= 0.410 P2= 4.19"
3.8	41	0.1940	0.18		Sheet Flow, Sheet Flow
					Grass: Bermuda n= 0.410 P2= 4.19"
0.1	6	0.0100	0.68		Sheet Flow, Sheet Flow
					Smooth surfaces n= 0.011 P2= 4.19"
0.1	51	0.0870	5.99		Shallow Concentrated Flow, Concentrated Flow
					Paved Kv= 20.3 fps
0.2	52	0.0310	3.57		Shallow Concentrated Flow, Concentrated Flow
					Paved Kv= 20.3 fps
0.1	18	0.0270	3.34		Shallow Concentrated Flow, Concentrated Flow
					Paved Kv= 20.3 fps
0.1	20	0.0400	4.06		Shallow Concentrated Flow, Concentrated Flow
					Paved Kv= 20.3 fps
0.1	34	0.0410	4.11		Shallow Concentrated Flow, Concentrated Flow
					Paved Kv= 20.3 fps
0.2	46	0.0470	4.40		Shallow Concentrated Flow, Concentrated Flow
					Paved Kv= 20.3 fps
0.1	36	0.0580	4.89		Shallow Concentrated Flow, Concentrated Flow
					Paved Kv= 20.3 fps
0.2	58	0.0690	5.33		Shallow Concentrated Flow, Concentrated Flow
					Paved Kv= 20.3 fps
0.1	49	0.0840	5.88		Shallow Concentrated Flow, Concentrated Flow
					Paved Kv= 20.3 fps
0.1	31	0.0690	5.33		Shallow Concentrated Flow, Concentrated Flow
					Paved Kv= 20.3 fps
15.9	492	Total			

Subcatchment C14: Drainage Basin C14

Hydrograph

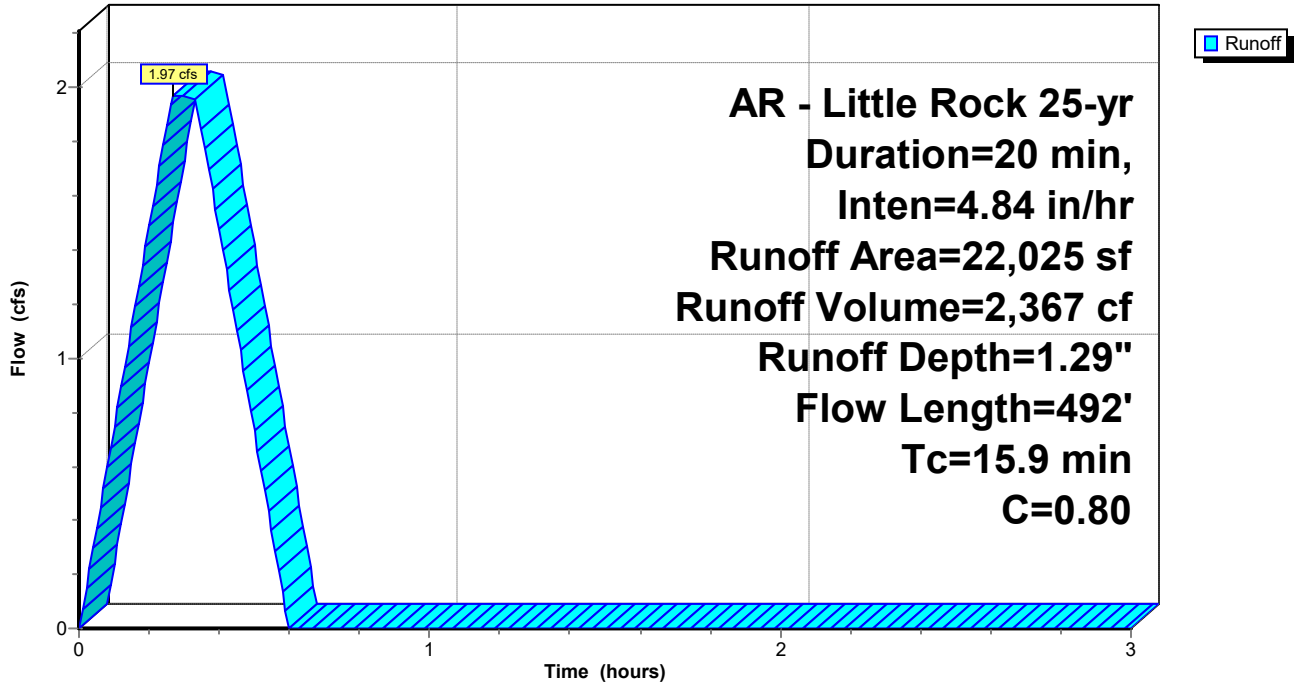

Summary for Subcatchment C15: Drainage Basin C15

Runoff = 1.43 cfs @ 0.09 hrs, Volume= 1,716 cf, Depth= 1.53"

Routed to Pond DP : Existing North Detention Pond

Runoff by Rational method, Rise/Fall=1.0/1.0 xTc, Time Span= 0.00-3.00 hrs, dt= 0.01 hrs

AR - Little Rock 25-yr Duration=20 min, Inten=4.84 in/hr

Area (sf)	C	Description
0	0.40	Sod Yard
13,450	0.95	Paving, Sidewalks
13,450	0.95	Weighted Average
13,450		100.00% Impervious Area

Tc (min)	Length (feet)	Slope (ft/ft)	Velocity (ft/sec)	Capacity (cfs)	Description
5.0	415		1.38		Direct Entry, Overland Concentrated Flow (Min)

Subcatchment C15: Drainage Basin C15

Hydrograph

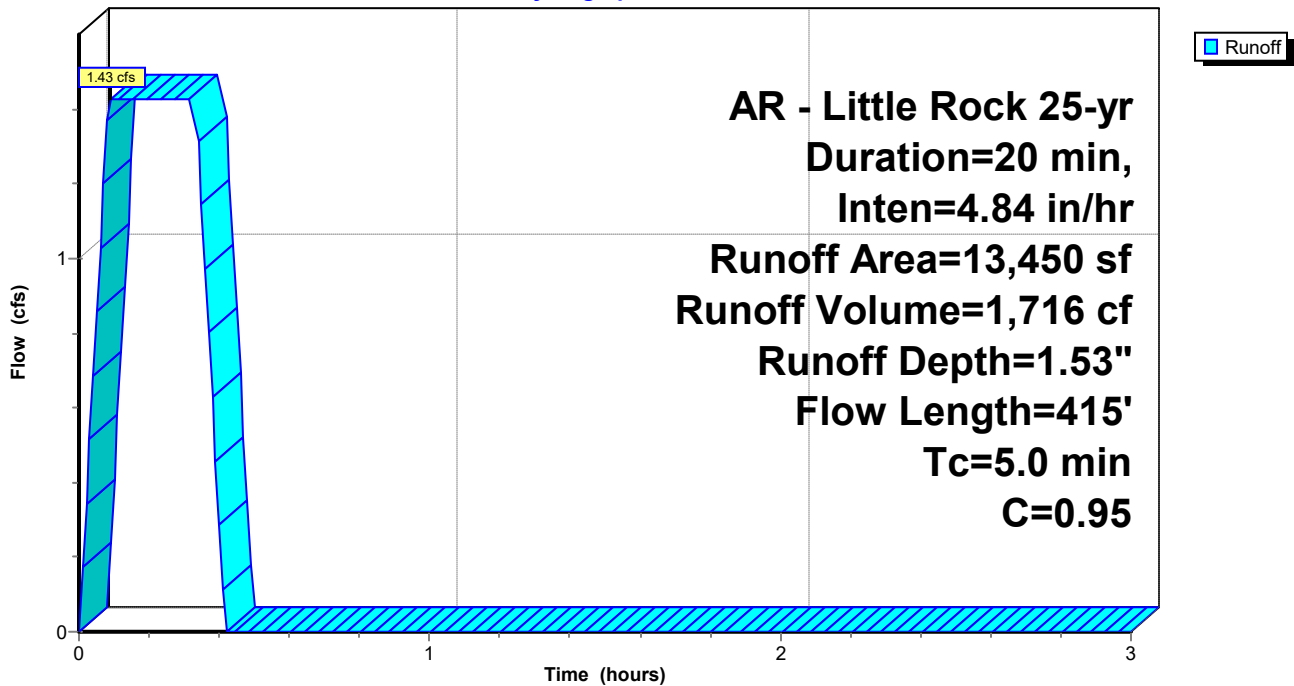

Goddard

Prepared by Phillip Lewis Engineering

HydroCAD® 10.20-5c s/n 12520 © 2023 HydroCAD Software Solutions LLC

AR - Little Rock 25-yr Duration=20 min, Inten=4.84 in/hr

Printed 3/25/2026

Summary for Subcatchment C16: Drainage Basin C16

Runoff = 1.38 cfs @ 0.09 hrs, Volume= 1,661 cf, Depth= 0.90"

Routed to Pond DP : Existing North Detention Pond

Runoff by Rational method, Rise/Fall=1.0/1.0 xTc, Time Span= 0.00-3.00 hrs, dt= 0.01 hrs

AR - Little Rock 25-yr Duration=20 min, Inten=4.84 in/hr

Area (sf)	C	Description
15,465	0.40	Sod Yard
6,612	0.95	Paving, Sidewalks
22,077	0.56	Weighted Average
15,465		70.05% Pervious Area
6,612		29.95% Impervious Area

Tc (min)	Length (feet)	Slope (ft/ft)	Velocity (ft/sec)	Capacity (cfs)	Description
0.4	26	0.0190	1.18		Sheet Flow, Sheet Flow
					Smooth surfaces n= 0.011 P2= 4.19"
0.1	5	0.0100	0.66		Sheet Flow, Sheet Flow
					Smooth surfaces n= 0.011 P2= 4.19"
0.4	51	0.0500	1.98		Sheet Flow, Sheet Flow
					Smooth surfaces n= 0.011 P2= 4.19"
0.1	12	0.1540	2.33		Sheet Flow, Sheet Flow
					Smooth surfaces n= 0.011 P2= 4.19"
0.1	50	0.1330	7.40		Shallow Concentrated Flow, Concentrated Flow
					Paved Kv= 20.3 fps
0.1	50	0.1170	6.94		Shallow Concentrated Flow, Concentrated Flow
					Paved Kv= 20.3 fps
0.2	46	0.0430	4.21		Shallow Concentrated Flow, Concentrated Flow
					Paved Kv= 20.3 fps
0.3	59	0.0370	3.90		Shallow Concentrated Flow, Concentrated Flow
					Paved Kv= 20.3 fps
3.3	415		2.10		Direct Entry, Overland Concentrated Flow (Min)
5.0	714	Total			

Subcatchment C16: Drainage Basin C16

Hydrograph

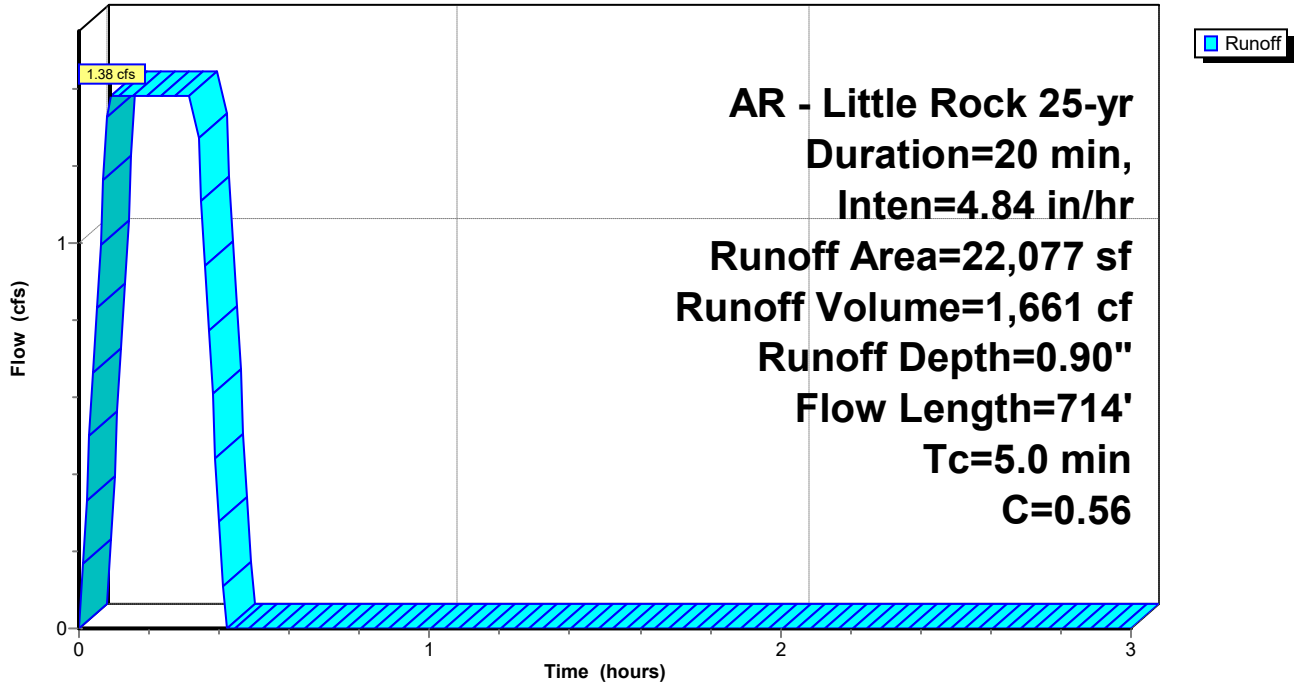

Goddard

Prepared by Phillip Lewis Engineering

HydroCAD® 10.20-5c s/n 12520 © 2023 HydroCAD Software Solutions LLC

AR - Little Rock 25-yr Duration=20 min, Inten=4.84 in/hr

Printed 3/25/2026

Summary for Subcatchment C17: Drainage Basin C17

Runoff = 2.54 cfs @ 0.16 hrs, Volume= 3,050 cf, Depth= 0.65"

Routed to Pond DP : Existing North Detention Pond

Runoff by Rational method, Rise/Fall=1.0/1.0 xTc, Time Span= 0.00-3.00 hrs, dt= 0.01 hrs

AR - Little Rock 25-yr Duration=20 min, Inten=4.84 in/hr

Area (sf)	C	Description
56,749	0.40	Sod Yard
0	0.95	Paving, Sidewalks
56,749	0.40	Weighted Average
56,749		100.00% Pervious Area

Tc (min)	Length (feet)	Slope (ft/ft)	Velocity (ft/sec)	Capacity (cfs)	Description
4.8	43	0.0410	0.15		Sheet Flow, Sheet Flow Grass: Dense n= 0.240 P2= 4.19"
3.9	43	0.0690	0.19		Sheet Flow, Sheet Flow Grass: Dense n= 0.240 P2= 4.19"
0.1	41	0.0980	4.70		Shallow Concentrated Flow, Concentrated Flow Grassed Waterway Kv= 15.0 fps
0.3	61	0.0730	4.05		Shallow Concentrated Flow, Concentrated Flow Grassed Waterway Kv= 15.0 fps
0.2	46	0.0570	3.58		Shallow Concentrated Flow, Concentrated Flow Grassed Waterway Kv= 15.0 fps
0.3	64	0.0450	3.18		Shallow Concentrated Flow, Concentrated Flow Grassed Waterway Kv= 15.0 fps
9.6	298	Total			

Subcatchment C17: Drainage Basin C17

Hydrograph

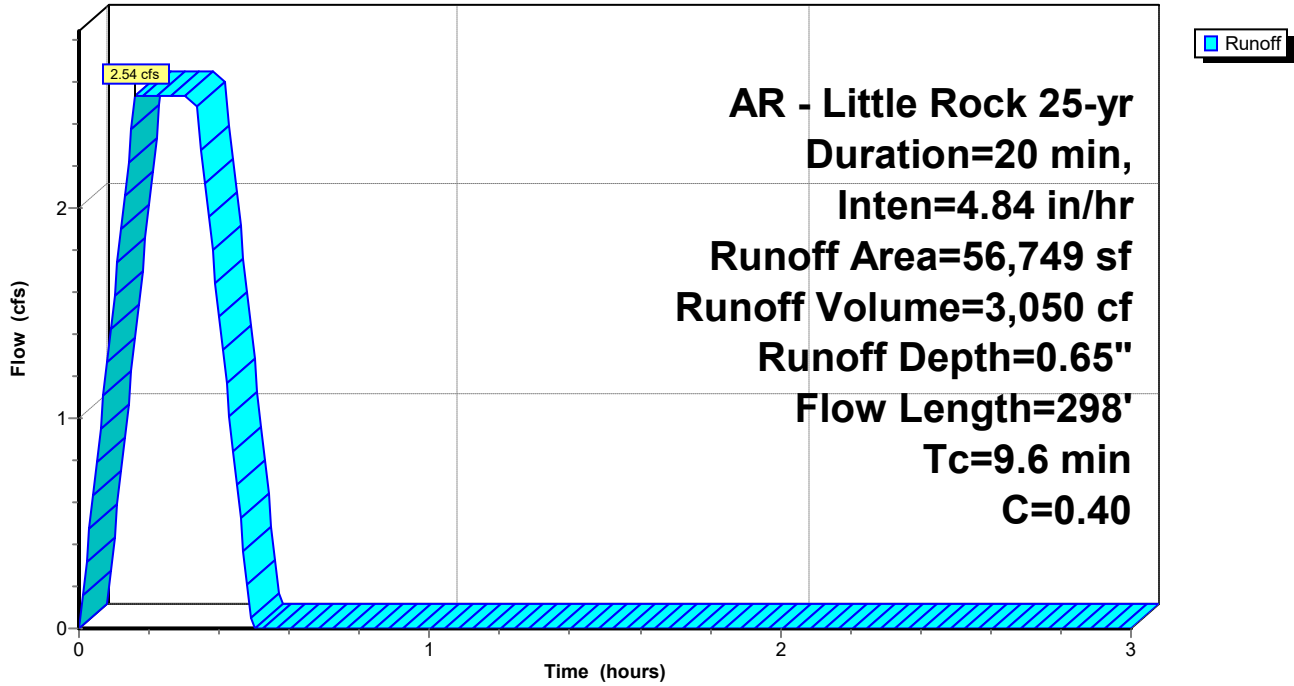

Goddard

Prepared by Phillip Lewis Engineering

HydroCAD® 10.20-5c s/n 12520 © 2023 HydroCAD Software Solutions LLC

AR - Little Rock 25-yr Duration=20 min, Inten=4.84 in/hr

Printed 3/25/2026

Summary for Subcatchment C18: Drainage Basin C18

Runoff = 1.63 cfs @ 0.09 hrs, Volume= 1,959 cf, Depth= 1.03"

Routed to Link FINAL : APPROX DISCHARGE

Runoff by Rational method, Rise/Fall=1.0/1.0 xTc, Time Span= 0.00-3.00 hrs, dt= 0.01 hrs

AR - Little Rock 25-yr Duration=20 min, Inten=4.84 in/hr

Area (sf)	C	Description
12,812	0.40	Sod Yard
9,973	0.95	Paving, Sidewalks
22,785	0.64	Weighted Average
12,812		56.23% Pervious Area
9,973		43.77% Impervious Area

Tc (min)	Length (feet)	Slope (ft/ft)	Velocity (ft/sec)	Capacity (cfs)	Description
0.6	5	0.2980	0.14		Sheet Flow, Sheet Flow Grass: Bermuda n= 0.410 P2= 4.19"
0.2	12	0.0130	0.87		Sheet Flow, Sheet Flow Smooth surfaces n= 0.011 P2= 4.19"
3.3	8	0.0100	0.04		Sheet Flow, Sheet Flow Grass: Bermuda n= 0.410 P2= 4.19"
0.5	80	0.0210	2.94		Shallow Concentrated Flow, Concentrated Flow Paved Kv= 20.3 fps
0.4	415		17.29		Direct Entry, Concentrated Flow (Min)
5.0	520	Total			

Subcatchment C18: Drainage Basin C18

Hydrograph

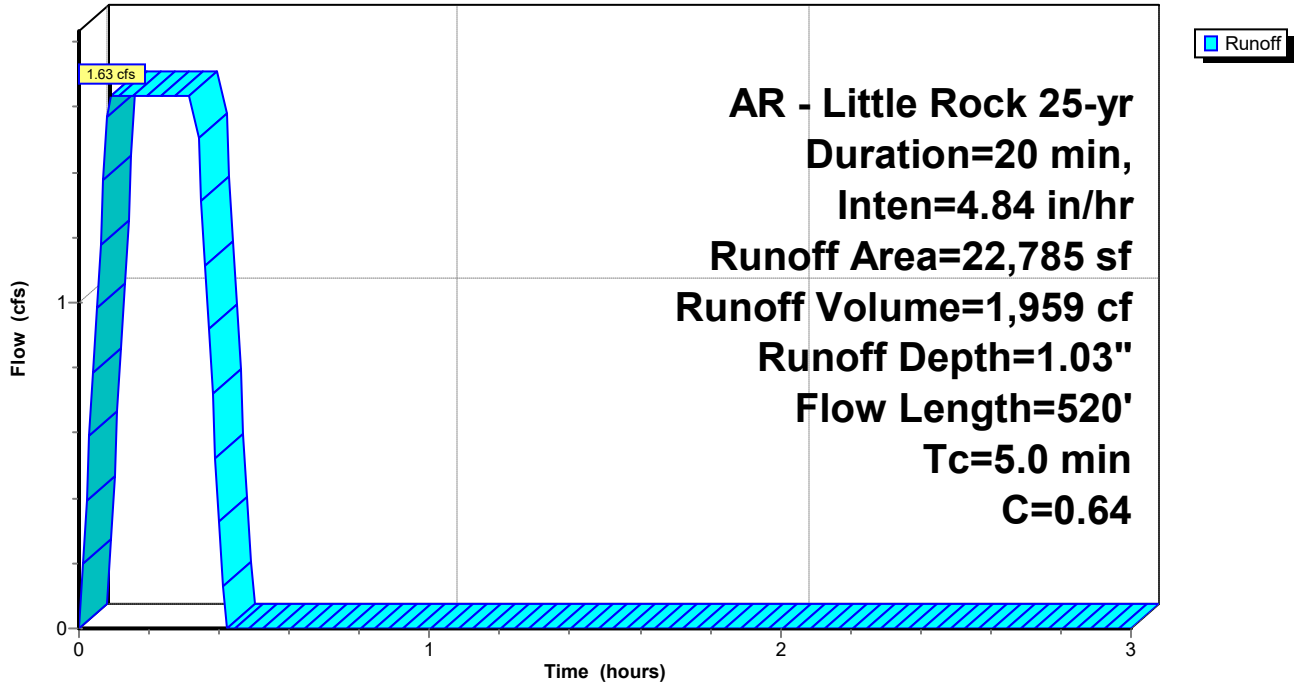

Goddard

Prepared by Phillip Lewis Engineering

HydroCAD® 10.20-5c s/n 12520 © 2023 HydroCAD Software Solutions LLC

AR - Little Rock 25-yr Duration=20 min, Inten=4.84 in/hr

Printed 3/25/2026

Summary for Subcatchment C19: Drainage Basin C19

Runoff = 0.81 cfs @ 0.12 hrs, Volume= 968 cf, Depth= 0.65"
 Routed to Link FINAL : APPROX DISCHARGE

Runoff by Rational method, Rise/Fall=1.0/1.0 xTc, Time Span= 0.00-3.00 hrs, dt= 0.01 hrs
 AR - Little Rock 25-yr Duration=20 min, Inten=4.84 in/hr

Area (sf)	C	Description
18,009	0.40	Sod Yard
0	0.95	Paving, Sidewalks
18,009	0.40	Weighted Average
18,009		100.00% Pervious Area

Tc (min)	Length (feet)	Slope (ft/ft)	Velocity (ft/sec)	Capacity (cfs)	Description
2.7	34	0.1110	0.21		Sheet Flow, Sheet Flow
					Grass: Dense n= 0.240 P2= 4.19"
3.3	66	0.2450	0.34		Sheet Flow, Sheet Flow
					Grass: Dense n= 0.240 P2= 4.19"
0.0	9	0.2450	7.42		Shallow Concentrated Flow, Concentrated Flow
					Grassed Waterway Kv= 15.0 fps
0.5	106	0.0610	3.70		Shallow Concentrated Flow, Concentrated Flow
					Grassed Waterway Kv= 15.0 fps
0.2	46	0.0800	4.24		Shallow Concentrated Flow, Concentrated Flow
					Grassed Waterway Kv= 15.0 fps
0.1	41	0.0960	4.65		Shallow Concentrated Flow, Concentrated Flow
					Grassed Waterway Kv= 15.0 fps
0.3	66	0.0680	3.91		Shallow Concentrated Flow, Concentrated Flow
					Grassed Waterway Kv= 15.0 fps
0.1	19	0.1070	4.91		Shallow Concentrated Flow, Concentrated Flow
					Grassed Waterway Kv= 15.0 fps
0.0	6	0.0750	4.11		Shallow Concentrated Flow, Concentrated Flow
					Grassed Waterway Kv= 15.0 fps
7.2	393	Total			

Subcatchment C19: Drainage Basin C19

Hydrograph

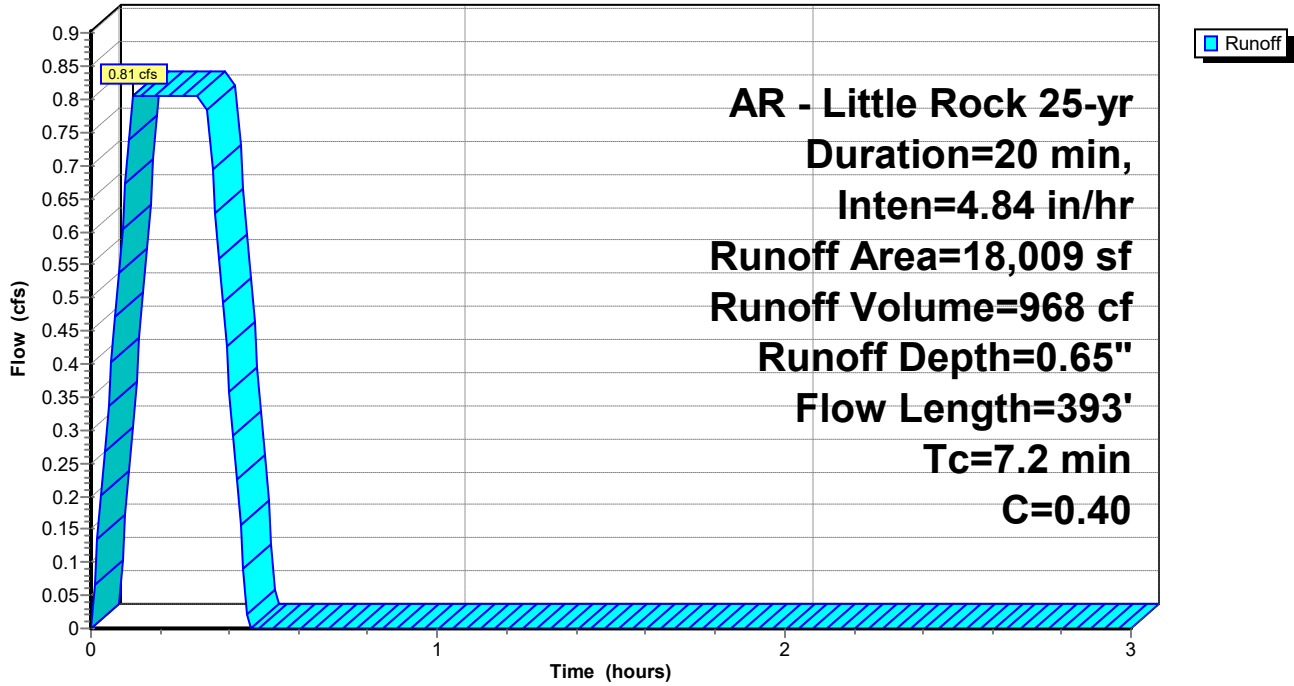

Goddard

Prepared by Phillip Lewis Engineering

HydroCAD® 10.20-5c s/n 12520 © 2023 HydroCAD Software Solutions LLC

AR - Little Rock 25-yr Duration=20 min, Inten=4.84 in/hr

Printed 3/25/2026

Summary for Subcatchment C2: Drainage Basin C2

Runoff = 2.96 cfs @ 0.09 hrs, Volume= 3,552 cf, Depth= 1.24"
 Routed to Pond CI-C2 : CI - C2

Runoff by Rational method, Rise/Fall=1.0/1.0 xTc, Time Span= 0.00-3.00 hrs, dt= 0.01 hrs
 AR - Little Rock 25-yr Duration=20 min, Inten=4.84 in/hr

Area (sf)	C	Description
11,376	0.40	Sod Yard
22,963	0.95	Roof, Paving, Sidewalks
34,339	0.77	Weighted Average
11,376		33.13% Pervious Area
22,963		66.87% Impervious Area

Tc (min)	Length (feet)	Slope (ft/ft)	Velocity (ft/sec)	Capacity (cfs)	Description
0.3	20	0.0200	1.14		Sheet Flow, Sheet Flow Smooth surfaces n= 0.011 P2= 4.19"
0.4	74	0.0240	3.14		Shallow Concentrated Flow, Concentrated Flow Paved Kv= 20.3 fps
0.1	17	0.0710	5.41		Shallow Concentrated Flow, Concentrated Flow Paved Kv= 20.3 fps
0.1	21	0.0610	5.01		Shallow Concentrated Flow, Concentrated Flow Paved Kv= 20.3 fps
0.6	148	0.0380	3.96		Shallow Concentrated Flow, Concentrated Flow Paved Kv= 20.3 fps
3.5	415		1.98		Direct Entry, Concentrated Flow (Min)
5.0	695	Total			

Subcatchment C2: Drainage Basin C2

Hydrograph

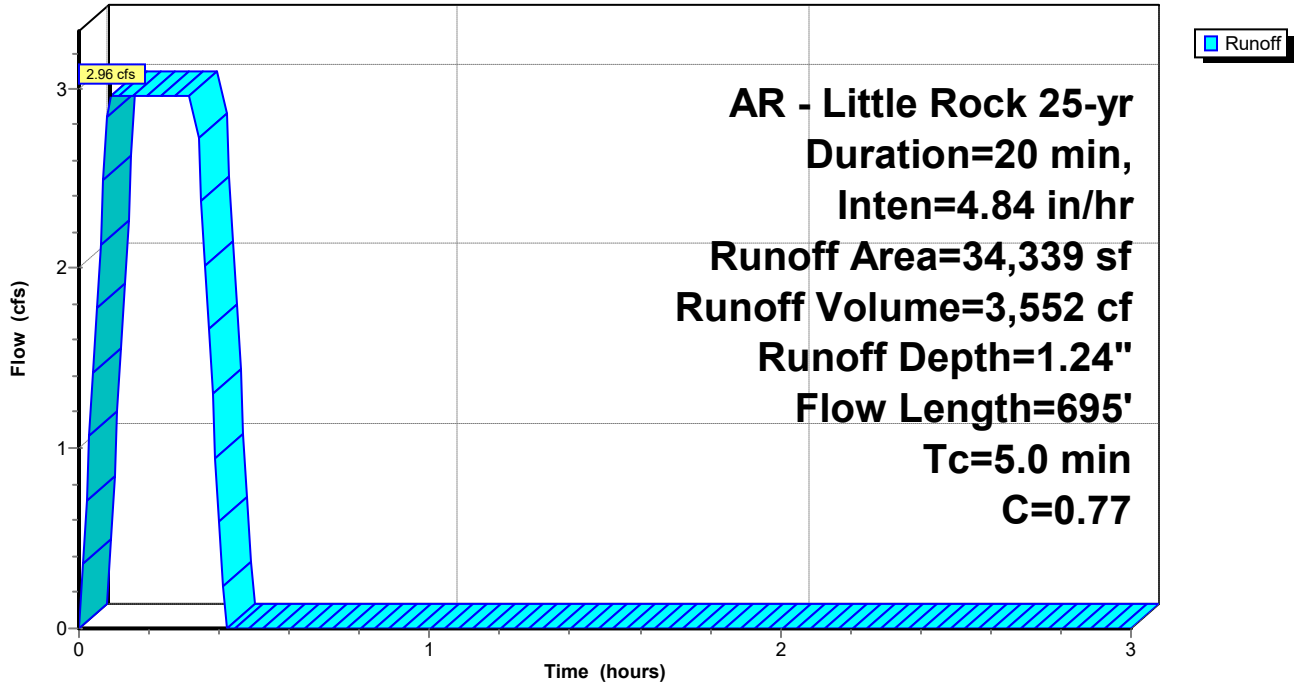

Goddard

Prepared by Phillip Lewis Engineering

HydroCAD® 10.20-5c s/n 12520 © 2023 HydroCAD Software Solutions LLC

AR - Little Rock 25-yr Duration=20 min, Inten=4.84 in/hr

Printed 3/25/2026

Summary for Subcatchment C20: Drainage Basin C20

Runoff = 1.38 cfs @ 0.14 hrs, Volume= 1,655 cf, Depth= 0.64"
 Routed to Link FINAL : APPROX DISCHARGE

Runoff by Rational method, Rise/Fall=1.0/1.0 xTc, Time Span= 0.00-3.00 hrs, dt= 0.01 hrs
 AR - Little Rock 25-yr Duration=20 min, Inten=4.84 in/hr

Area (sf)	C	Description
30,789	0.40	Sod Yard
0	0.95	Paving, Sidewalks
30,789	0.40	Weighted Average
30,789		100.00% Pervious Area

Tc (min)	Length (feet)	Slope (ft/ft)	Velocity (ft/sec)	Capacity (cfs)	Description
3.0	45	0.1430	0.25		Sheet Flow, Sheet Flow Grass: Dense n= 0.240 P2= 4.19"
4.5	55	0.0780	0.20		Sheet Flow, Sheet Flow Grass: Dense n= 0.240 P2= 4.19"
0.1	37	0.0780	4.19		Shallow Concentrated Flow, Concentrated Flow Grassed Waterway Kv= 15.0 fps
0.3	68	0.0710	4.00		Shallow Concentrated Flow, Concentrated Flow Grassed Waterway Kv= 15.0 fps
7.9	205	Total			

Subcatchment C20: Drainage Basin C20

Hydrograph

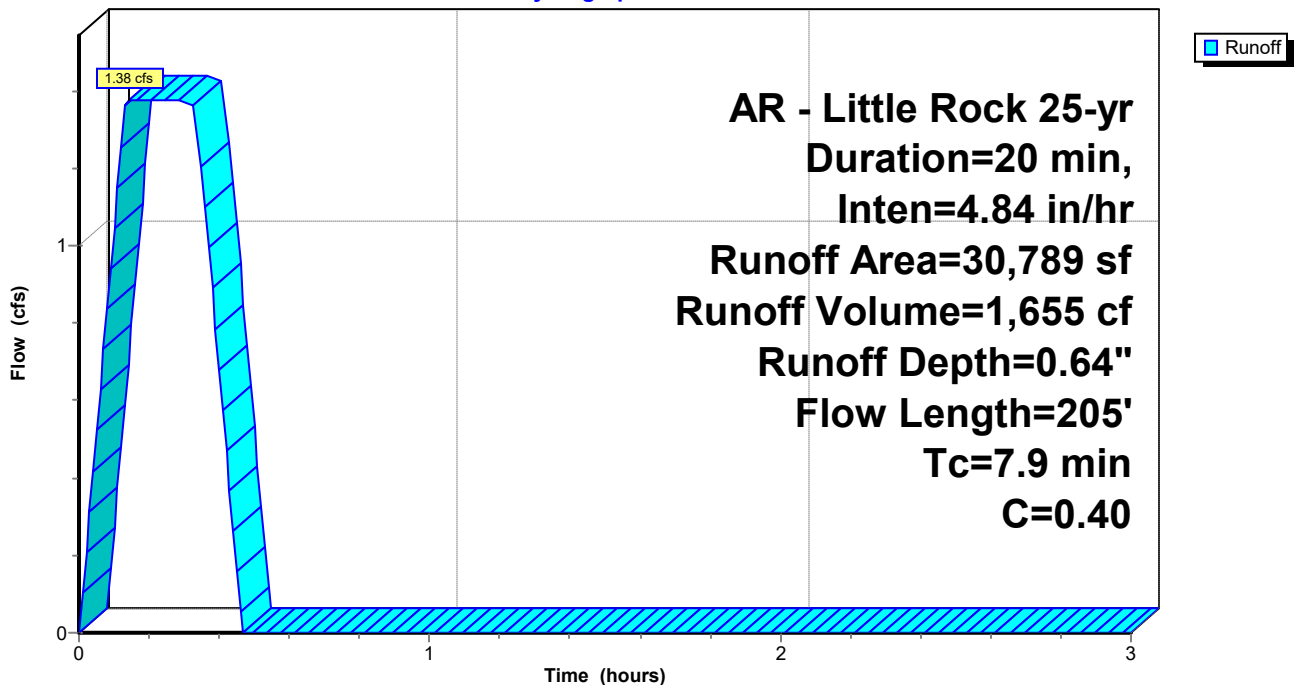

Goddard

Prepared by Phillip Lewis Engineering

HydroCAD® 10.20-5c s/n 12520 © 2023 HydroCAD Software Solutions LLC

AR - Little Rock 25-yr Duration=20 min, Inten=4.84 in/hr

Printed 3/25/2026

Summary for Subcatchment C3: Drainage Basin C3

Runoff = 0.37 cfs @ 0.09 hrs, Volume= 444 cf, Depth= 1.53"
 Routed to Pond CI-C3 : CI - C3

Runoff by Rational method, Rise/Fall=1.0/1.0 xTc, Time Span= 0.00-3.00 hrs, dt= 0.01 hrs
 AR - Little Rock 25-yr Duration=20 min, Inten=4.84 in/hr

Area (sf)	C	Description
0	0.40	Sod Yard
3,480	0.95	Paving, Sidewalks
3,480	0.95	Weighted Average
3,480		100.00% Impervious Area

Tc (min)	Length (feet)	Slope (ft/ft)	Velocity (ft/sec)	Capacity (cfs)	Description
0.3	22	0.0200	1.16		Sheet Flow, Sheet Flow Smooth surfaces n= 0.011 P2= 4.19"
0.0	10	0.0340	3.74		Shallow Concentrated Flow, Concentrated Flow Paved Kv= 20.3 fps
0.1	18	0.0390	4.01		Shallow Concentrated Flow, Concentrated Flow Paved Kv= 20.3 fps
0.6	147	0.0380	3.96		Shallow Concentrated Flow, Concentrated Flow Paved Kv= 20.3 fps
4.0	415		1.73		Direct Entry, Concentrated Flow (Min)
5.0	612	Total			

Subcatchment C3: Drainage Basin C3

Hydrograph

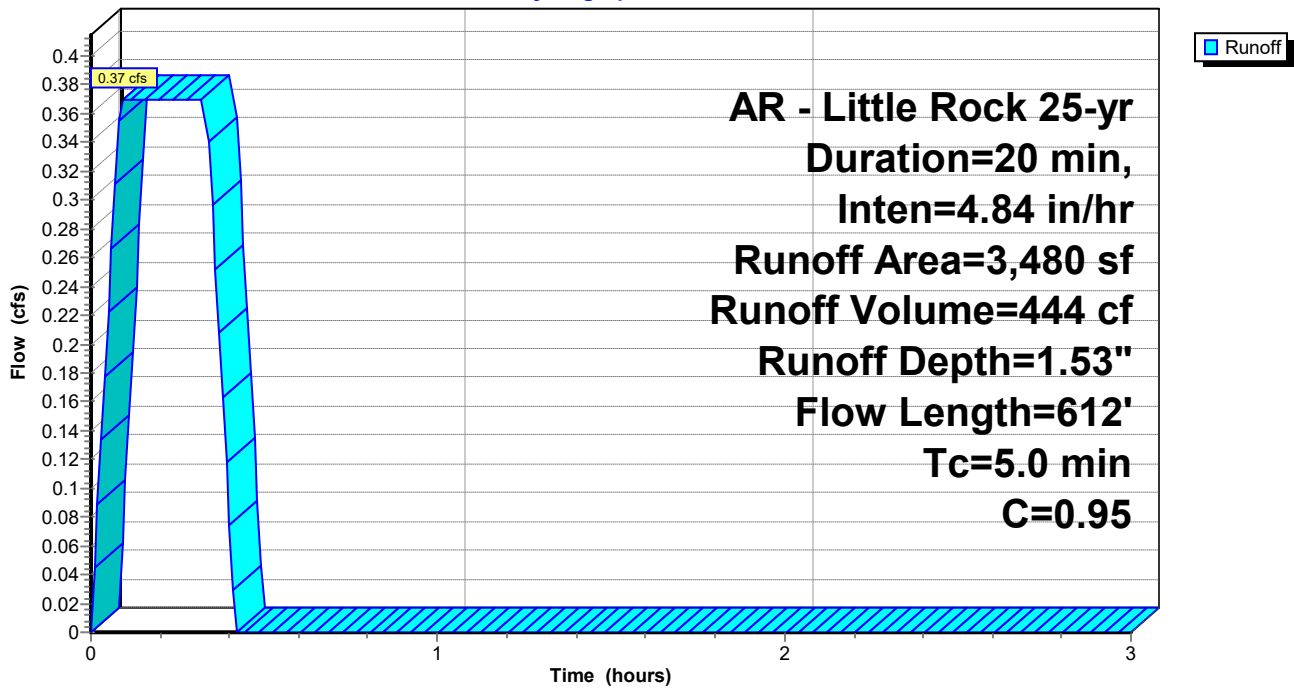

Summary for Subcatchment C4: Drainage Basin C4

Runoff = 0.71 cfs @ 0.09 hrs, Volume= 856 cf, Depth= 0.90"
 Routed to Pond CI-C3 : CI - C3

Runoff by Rational method, Rise/Fall=1.0/1.0 xTc, Time Span= 0.00-3.00 hrs, dt= 0.01 hrs
 AR - Little Rock 25-yr Duration=20 min, Inten=4.84 in/hr

Area (sf)	C	Description
8,130	0.40	Sod Yard
3,245	0.95	Paving, Sidewalks
11,375	0.56	Weighted Average
8,130		71.47% Pervious Area
3,245		28.53% Impervious Area

Tc (min)	Length (feet)	Slope (ft/ft)	Velocity (ft/sec)	Capacity (cfs)	Description
5.0	415		1.38		Direct Entry, Concentrated Flow (Min)

Subcatchment C4: Drainage Basin C4

Hydrograph

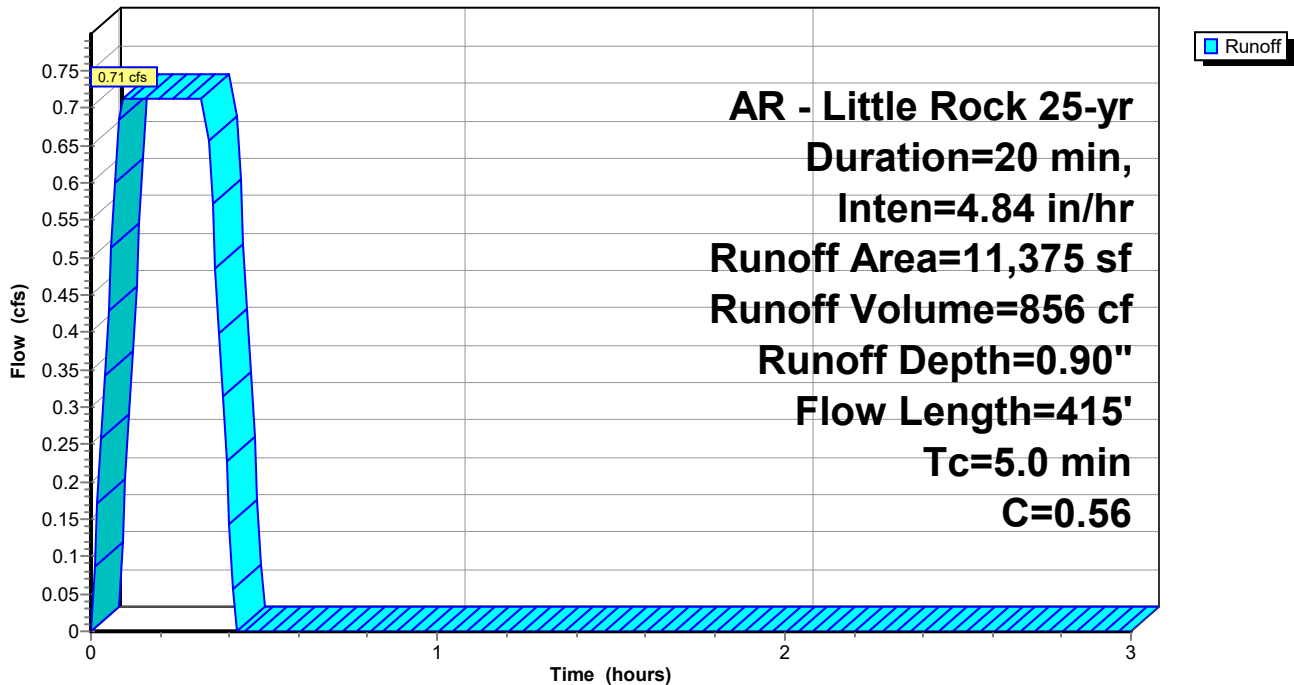

Goddard

Prepared by Phillip Lewis Engineering

HydroCAD® 10.20-5c s/n 12520 © 2023 HydroCAD Software Solutions LLC

AR - Little Rock 25-yr Duration=20 min, Inten=4.84 in/hr

Printed 3/25/2026

Summary for Subcatchment C5: Drainage Basin C5

Runoff = 0.61 cfs @ 0.10 hrs, Volume= 737 cf, Depth= 1.32"
 Routed to Pond CI-C4 : CI - C4

Runoff by Rational method, Rise/Fall=1.0/1.0 xTc, Time Span= 0.00-3.00 hrs, dt= 0.01 hrs
 AR - Little Rock 25-yr Duration=20 min, Inten=4.84 in/hr

Area (sf)	C	Description
1,634	0.40	Sod Yard
5,061	0.95	Paving, Sidewalks
6,695	0.82	Weighted Average
1,634		24.41% Pervious Area
5,061		75.59% Impervious Area

Tc (min)	Length (feet)	Slope (ft/ft)	Velocity (ft/sec)	Capacity (cfs)	Description
0.6	5	0.2990	0.14		Sheet Flow, Sheet Flow Grass: Bermuda n= 0.410 P2= 4.19"
0.2	12	0.0130	0.87		Sheet Flow, Sheet Flow Smooth surfaces n= 0.011 P2= 4.19"
3.9	8	0.0070	0.03		Sheet Flow, Sheet Flow Grass: Bermuda n= 0.410 P2= 4.19"
0.5	58	0.0080	1.82		Shallow Concentrated Flow, Concentrated Flow Paved Kv= 20.3 fps
0.1	14	0.0280	3.40		Shallow Concentrated Flow, Concentrated Flow Paved Kv= 20.3 fps
0.1	23	0.0370	3.90		Shallow Concentrated Flow, Concentrated Flow Paved Kv= 20.3 fps
0.0	13	0.0940	6.22		Shallow Concentrated Flow, Concentrated Flow Paved Kv= 20.3 fps
0.0	13	0.0560	4.80		Shallow Concentrated Flow, Concentrated Flow Paved Kv= 20.3 fps
0.2	30	0.0180	2.72		Shallow Concentrated Flow, Concentrated Flow Paved Kv= 20.3 fps
5.6	176	Total			

Subcatchment C5: Drainage Basin C5

Hydrograph

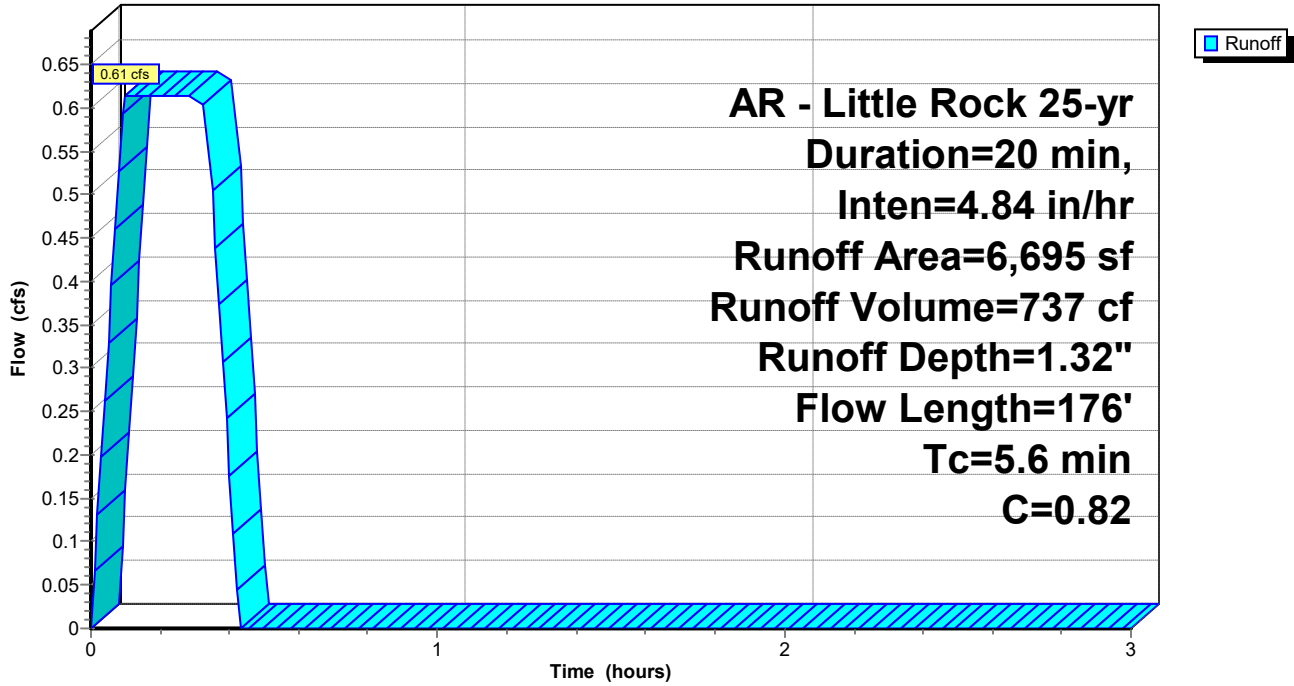

Goddard

Prepared by Phillip Lewis Engineering

HydroCAD® 10.20-5c s/n 12520 © 2023 HydroCAD Software Solutions LLC

AR - Little Rock 25-yr Duration=20 min, Inten=4.84 in/hr

Printed 3/25/2026

Summary for Subcatchment C6: Drainage Basin C6

Runoff = 0.30 cfs @ 0.09 hrs, Volume= 362 cf, Depth= 1.53"
 Routed to Pond CI-C5 : CI - C5

Runoff by Rational method, Rise/Fall=1.0/1.0 xTc, Time Span= 0.00-3.00 hrs, dt= 0.01 hrs
 AR - Little Rock 25-yr Duration=20 min, Inten=4.84 in/hr

Area (sf)	C	Description
0	0.40	Sod Yard
2,835	0.95	Paving, Sidewalks
2,835	0.95	Weighted Average
2,835		100.00% Impervious Area

Tc (min)	Length (feet)	Slope (ft/ft)	Velocity (ft/sec)	Capacity (cfs)	Description
0.3	22	0.0200	1.16		Sheet Flow, Sheet Flow Smooth surfaces n= 0.011 P2= 4.19"
0.2	19	0.0100	2.03		Shallow Concentrated Flow, Concentrated Flow Paved Kv= 20.3 fps
0.1	17	0.0170	2.65		Shallow Concentrated Flow, Concentrated Flow Paved Kv= 20.3 fps
0.1	26	0.0360	3.85		Shallow Concentrated Flow, Concentrated Flow Paved Kv= 20.3 fps
0.1	28	0.0610	5.01		Shallow Concentrated Flow, Concentrated Flow Paved Kv= 20.3 fps
0.1	27	0.0610	5.01		Shallow Concentrated Flow, Concentrated Flow Paved Kv= 20.3 fps
4.1	415		1.69		Direct Entry, Concentrated Flow (Min)
5.0	554	Total			

Subcatchment C6: Drainage Basin C6

Hydrograph

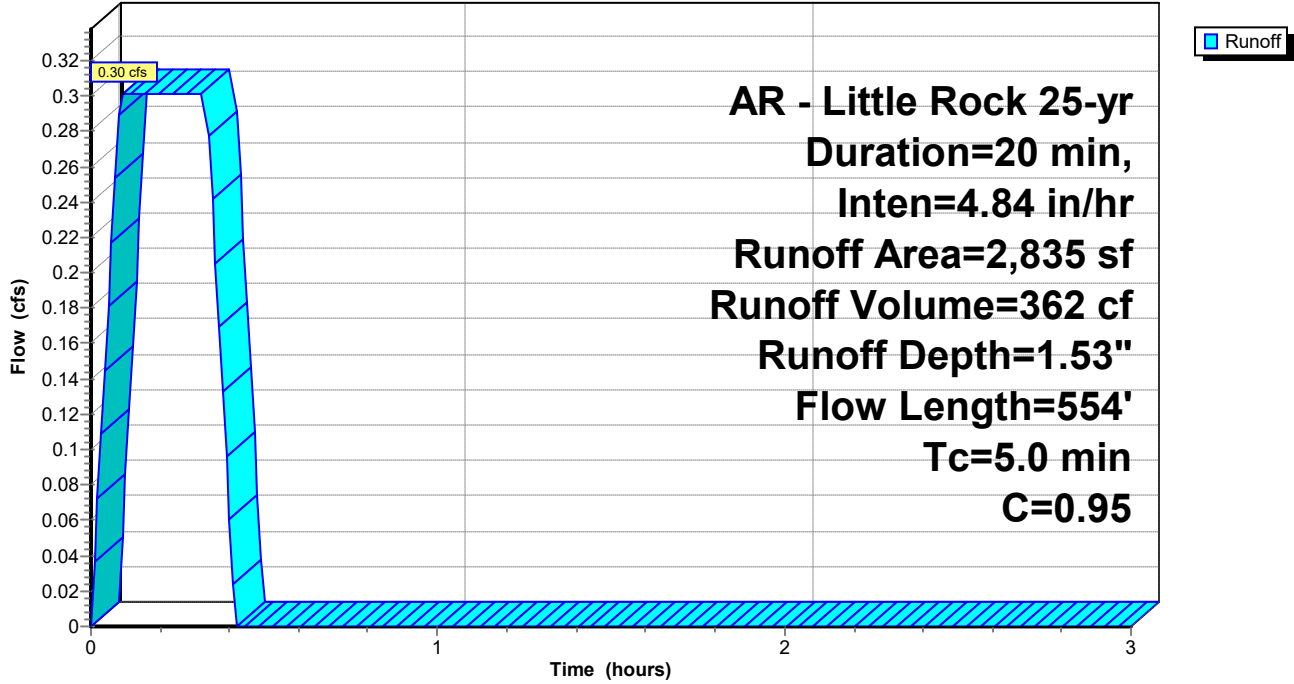

Goddard

Prepared by Phillip Lewis Engineering

HydroCAD® 10.20-5c s/n 12520 © 2023 HydroCAD Software Solutions LLC

AR - Little Rock 25-yr Duration=20 min, Inten=4.84 in/hr

Printed 3/25/2026

Summary for Subcatchment C7: Drainage Basin C7

Runoff = 0.17 cfs @ 0.09 hrs, Volume= 204 cf, Depth= 1.53"
 Routed to Pond CI-D1 : CI - D1

Runoff by Rational method, Rise/Fall=1.0/1.0 xTc, Time Span= 0.00-3.00 hrs, dt= 0.01 hrs
 AR - Little Rock 25-yr Duration=20 min, Inten=4.84 in/hr

Area (sf)	C	Description
0	0.40	Sod Yard
1,597	0.95	Paving, Sidewalks
1,597	0.95	Weighted Average
1,597		100.00% Impervious Area

Tc (min)	Length (feet)	Slope (ft/ft)	Velocity (ft/sec)	Capacity (cfs)	Description
0.3	19	0.0200	1.13		Sheet Flow, Sheet Flow Smooth surfaces n= 0.011 P2= 4.19"
0.1	16	0.0540	4.72		Shallow Concentrated Flow, Concentrated Flow Paved Kv= 20.3 fps
0.3	81	0.0580	4.89		Shallow Concentrated Flow, Concentrated Flow Paved Kv= 20.3 fps
4.3	415		1.61		Direct Entry, Concentrated Flow (Min)
5.0	531	Total			

Subcatchment C7: Drainage Basin C7

Hydrograph

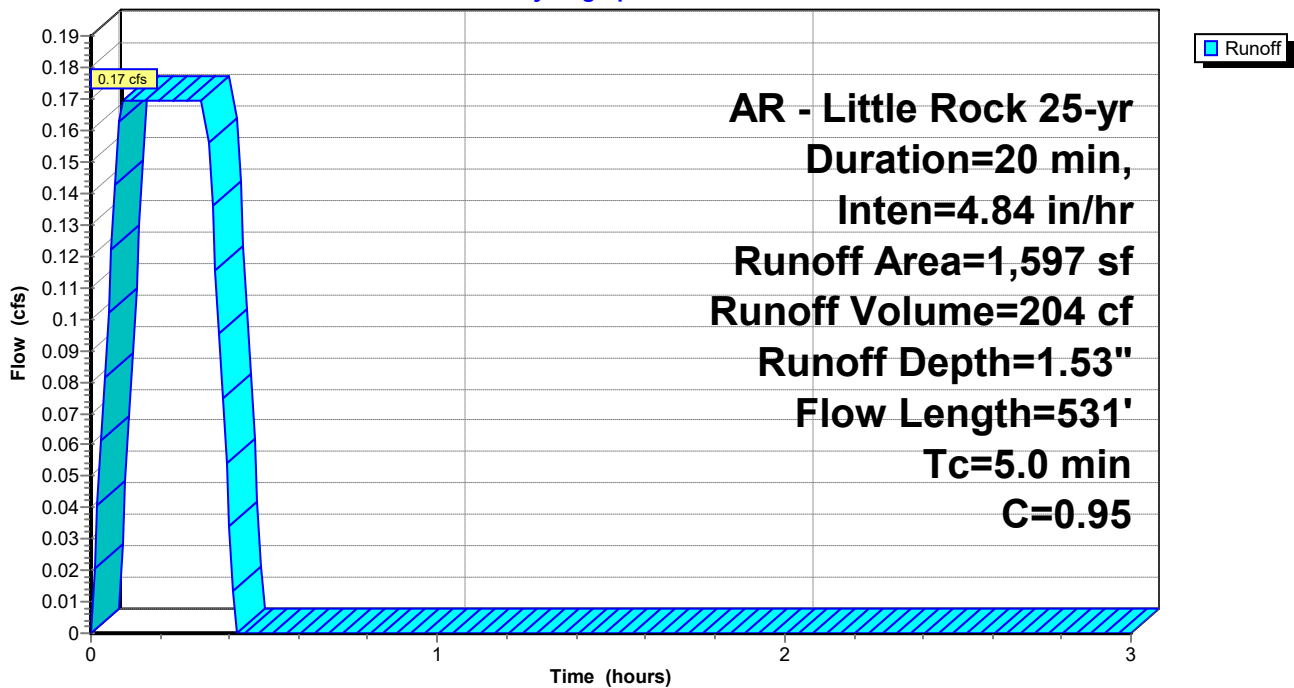

Summary for Subcatchment C8: Drainage Basin C8

Runoff = 0.16 cfs @ 0.09 hrs, Volume= 198 cf, Depth= 1.53"
 Routed to Pond CI-D2 : CI - D2

Runoff by Rational method, Rise/Fall=1.0/1.0 xTc, Time Span= 0.00-3.00 hrs, dt= 0.01 hrs
 AR - Little Rock 25-yr Duration=20 min, Inten=4.84 in/hr

Area (sf)	C	Description
0	0.40	Sod Yard
1,548	0.95	Paving, Sidewalks
1,548	0.95	Weighted Average
1,548		100.00% Impervious Area

Tc (min)	Length (feet)	Slope (ft/ft)	Velocity (ft/sec)	Capacity (cfs)	Description
0.3	18	0.0200	1.12		Sheet Flow, Sheet Flow Smooth surfaces n= 0.011 P2= 4.19"
0.3	94	0.0610	5.01		Shallow Concentrated Flow, Concentrated Flow Paved Kv= 20.3 fps
4.4	415		1.57		Direct Entry, Concentrated Flow (Min)
5.0	527	Total			

Subcatchment C8: Drainage Basin C8

Hydrograph

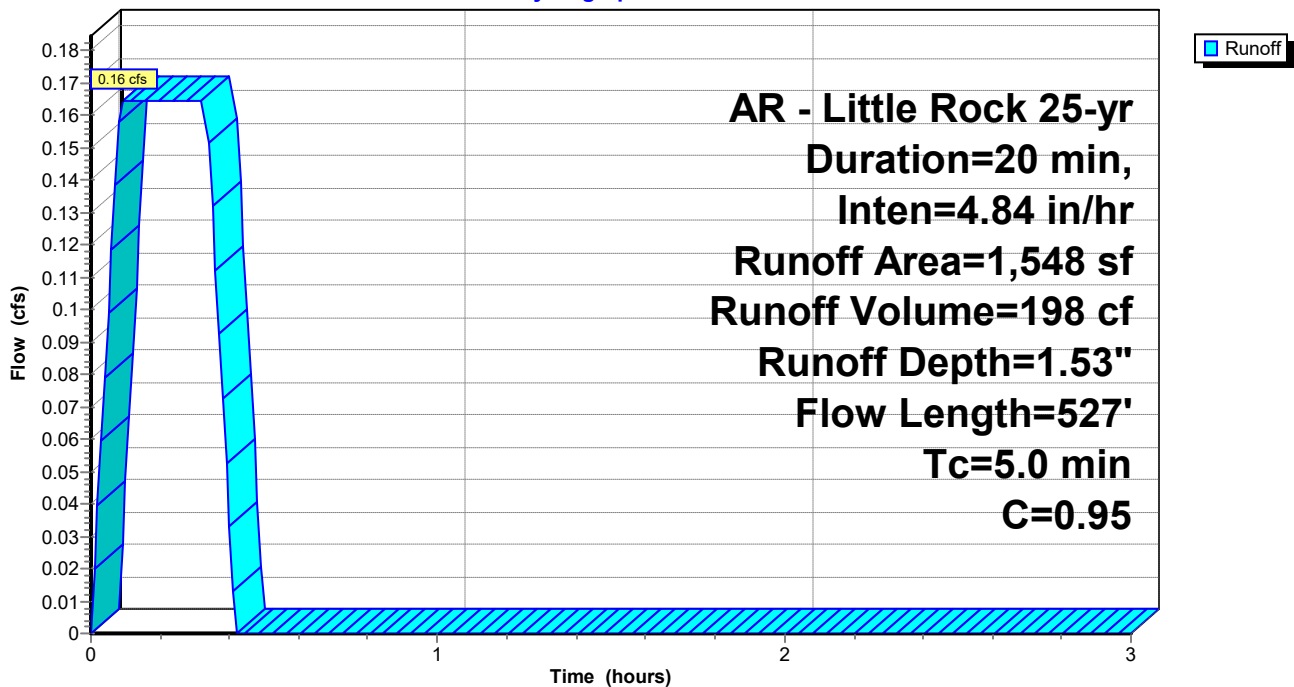

Goddard

Prepared by Phillip Lewis Engineering

HydroCAD® 10.20-5c s/n 12520 © 2023 HydroCAD Software Solutions LLC

AR - Little Rock 25-yr Duration=20 min, Inten=4.84 in/hr

Printed 3/25/2026

Summary for Subcatchment C9: Drainage Basin C9

Runoff = 1.19 cfs @ 0.09 hrs, Volume= 1,429 cf, Depth= 1.24"
 Routed to Pond CI-C6 : CI - C6

Runoff by Rational method, Rise/Fall=1.0/1.0 xTc, Time Span= 0.00-3.00 hrs, dt= 0.01 hrs
 AR - Little Rock 25-yr Duration=20 min, Inten=4.84 in/hr

Area (sf)	C	Description
4,456	0.40	Sod Yard
9,361	0.95	Paving, Sidewalks
13,817	0.77	Weighted Average
4,456		32.25% Pervious Area
9,361		67.75% Impervious Area

Tc (min)	Length (feet)	Slope (ft/ft)	Velocity (ft/sec)	Capacity (cfs)	Description
1.2	100	0.0140	1.36		Sheet Flow, Sheet Flow Smooth surfaces n= 0.011 P2= 4.19"
0.1	13	0.0150	2.49		Shallow Concentrated Flow, Concentrated Flow Paved Kv= 20.3 fps
0.1	23	0.0160	2.57		Shallow Concentrated Flow, Concentrated Flow Paved Kv= 20.3 fps
0.1	7	0.0050	1.44		Shallow Concentrated Flow, Concentrated Flow Paved Kv= 20.3 fps
0.1	8	0.0100	2.03		Shallow Concentrated Flow, Concentrated Flow Paved Kv= 20.3 fps
0.2	41	0.0420	4.16		Shallow Concentrated Flow, Concentrated Flow Paved Kv= 20.3 fps
0.1	41	0.0540	4.72		Shallow Concentrated Flow, Concentrated Flow Paved Kv= 20.3 fps
0.2	61	0.0520	4.63		Shallow Concentrated Flow, Concentrated Flow Paved Kv= 20.3 fps
2.9	415		2.39		Direct Entry, Concentrated Flow (Min)
5.0	709	Total			

Subcatchment C9: Drainage Basin C9

Hydrograph

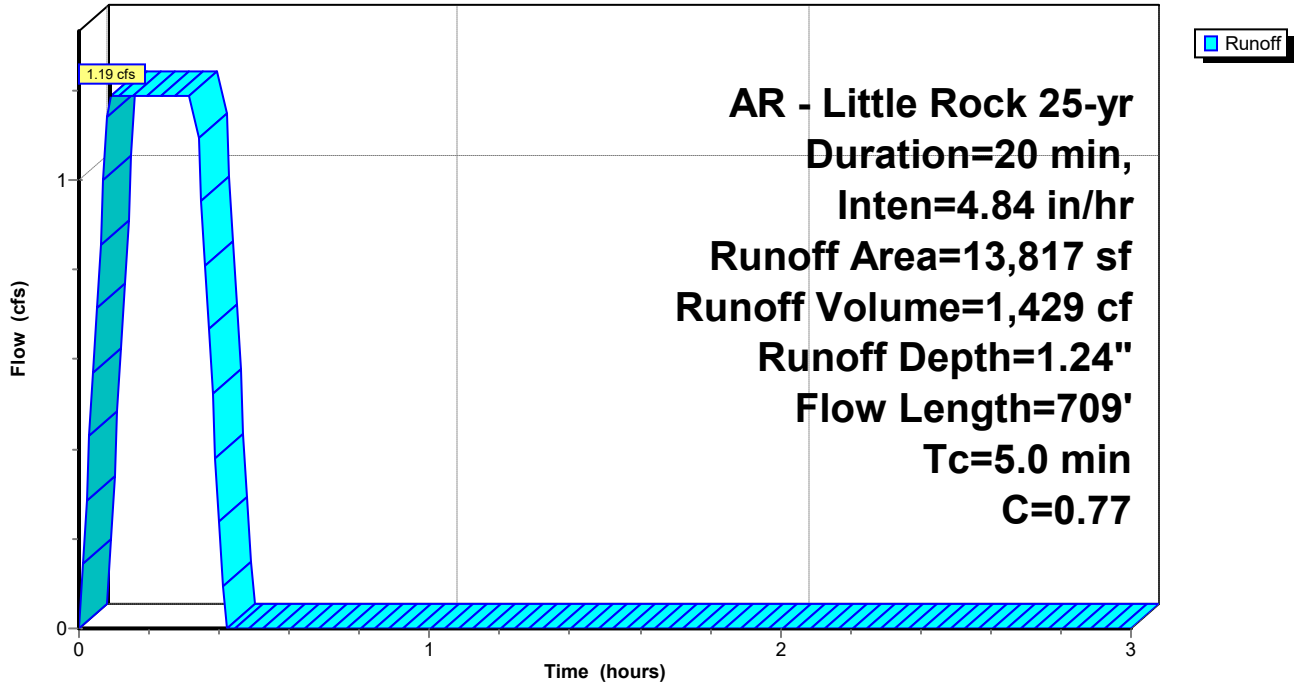

Summary for Pond CI-A1: CI - A1

Inflow Area = 19,493 sf, 74.78% Impervious, Inflow Depth = 1.35" for 25-yr event
Inflow = 1.83 cfs @ 0.09 hrs, Volume= 2,199 cf
Primary = 1.83 cfs @ 0.09 hrs, Volume= 2,199 cf, Atten= 0%, Lag= 0.0 min
Routed to Pond JB-A2 : JB - A2

Routing by Stor-Ind method, Time Span= 0.00-3.00 hrs, dt= 0.01 hrs

Pond CI-A1: CI - A1

Hydrograph

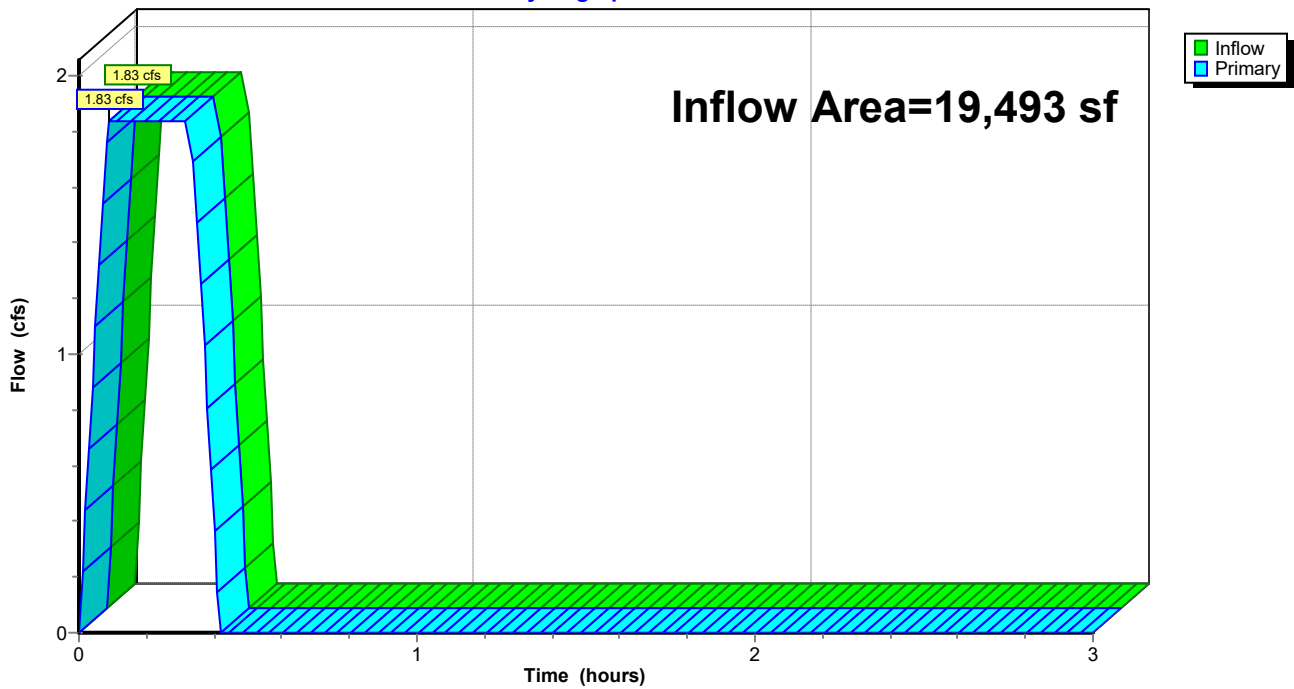

Summary for Pond CI-A3: CI - A3

Inflow Area = 52,824 sf, 61.20% Impervious, Inflow Depth = 1.26" for 25-yr event
Inflow = 4.61 cfs @ 0.17 hrs, Volume= 5,530 cf
Primary = 4.61 cfs @ 0.17 hrs, Volume= 5,530 cf, Atten= 0%, Lag= 0.0 min
Routed to Pond CI-A4 : CI - A4

Routing by Stor-Ind method, Time Span= 0.00-3.00 hrs, dt= 0.01 hrs

Pond CI-A3: CI - A3

Hydrograph

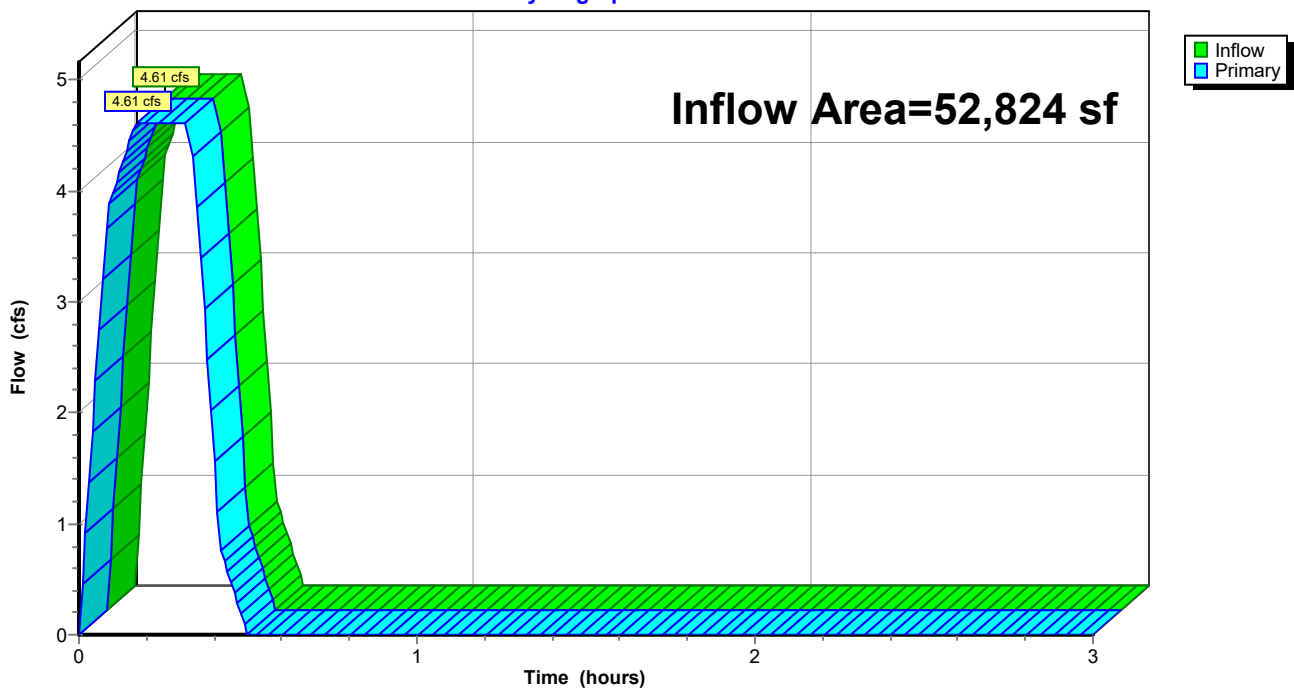

Summary for Pond CI-A4: CI - A4

Inflow Area = 75,210 sf, 60.06% Impervious, Inflow Depth = 1.25" for 25-yr event
Inflow = 6.51 cfs @ 0.24 hrs, Volume= 7,804 cf
Primary = 6.51 cfs @ 0.24 hrs, Volume= 7,804 cf, Atten= 0%, Lag= 0.0 min
Routed to Pond CI-A5 : CI - A5

Routing by Stor-Ind method, Time Span= 0.00-3.00 hrs, dt= 0.01 hrs

Pond CI-A4: CI - A4

Hydrograph

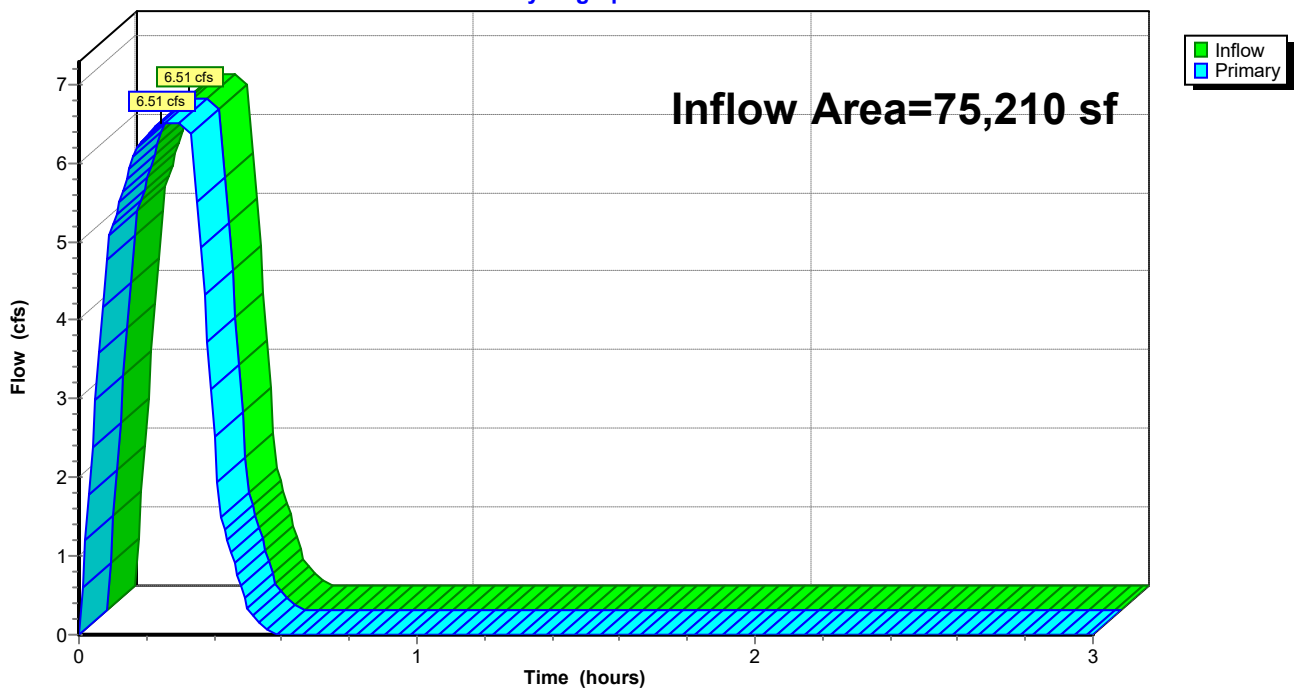

Summary for Pond CI-A5: CI - A5

Inflow Area = 97,235 sf, 62.81% Impervious, Inflow Depth = 1.26" for 25-yr event
Inflow = 8.48 cfs @ 0.27 hrs, Volume= 10,171 cf
Primary = 8.48 cfs @ 0.27 hrs, Volume= 10,171 cf, Atten= 0%, Lag= 0.0 min
Routed to Pond DP : Existing North Detention Pond

Routing by Stor-Ind method, Time Span= 0.00-3.00 hrs, dt= 0.01 hrs

Pond CI-A5: CI - A5

Hydrograph

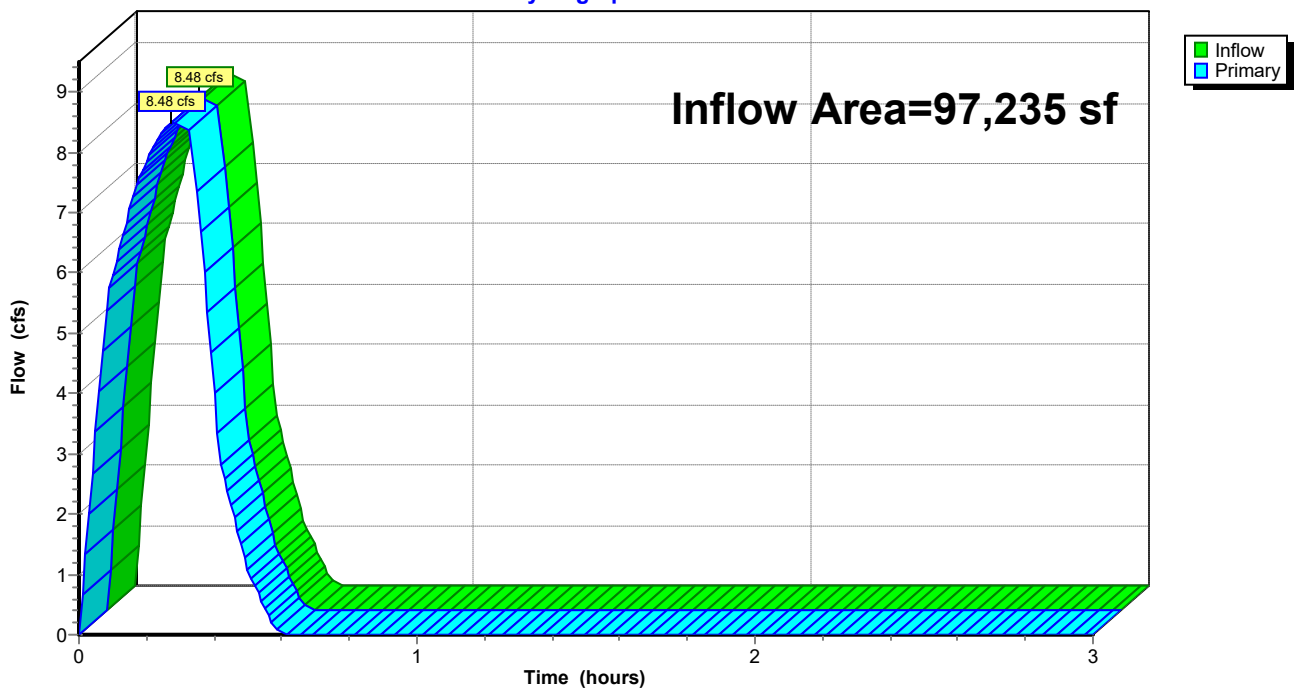

Summary for Pond CI-B2: CI - B2

Inflow Area = 22,169 sf, 29.72% Impervious, Inflow Depth = 1.03" for 25-yr event
Inflow = 1.59 cfs @ 0.17 hrs, Volume= 1,906 cf
Primary = 1.59 cfs @ 0.17 hrs, Volume= 1,906 cf, Atten= 0%, Lag= 0.0 min
Routed to Pond JB-A2 : JB - A2

Routing by Stor-Ind method, Time Span= 0.00-3.00 hrs, dt= 0.01 hrs

Pond CI-B2: CI - B2

Hydrograph

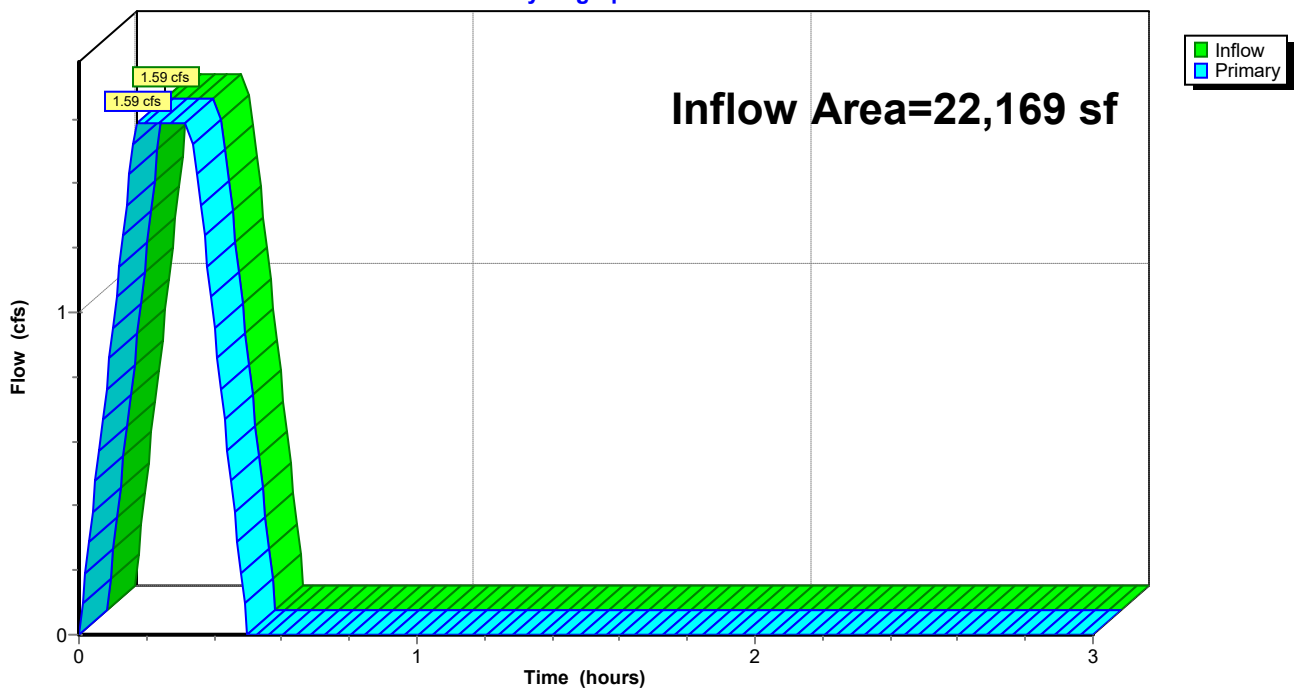

Summary for Pond CI-C1: CI - C1

Inflow Area = 20,337 sf, 69.83% Impervious, Inflow Depth = 1.26" for 25-yr event
Inflow = 1.78 cfs @ 0.09 hrs, Volume= 2,130 cf
Primary = 1.78 cfs @ 0.09 hrs, Volume= 2,130 cf, Atten= 0%, Lag= 0.0 min
Routed to Pond CI-C2 : CI - C2

Routing by Stor-Ind method, Time Span= 0.00-3.00 hrs, dt= 0.01 hrs

Pond CI-C1: CI - C1

Hydrograph

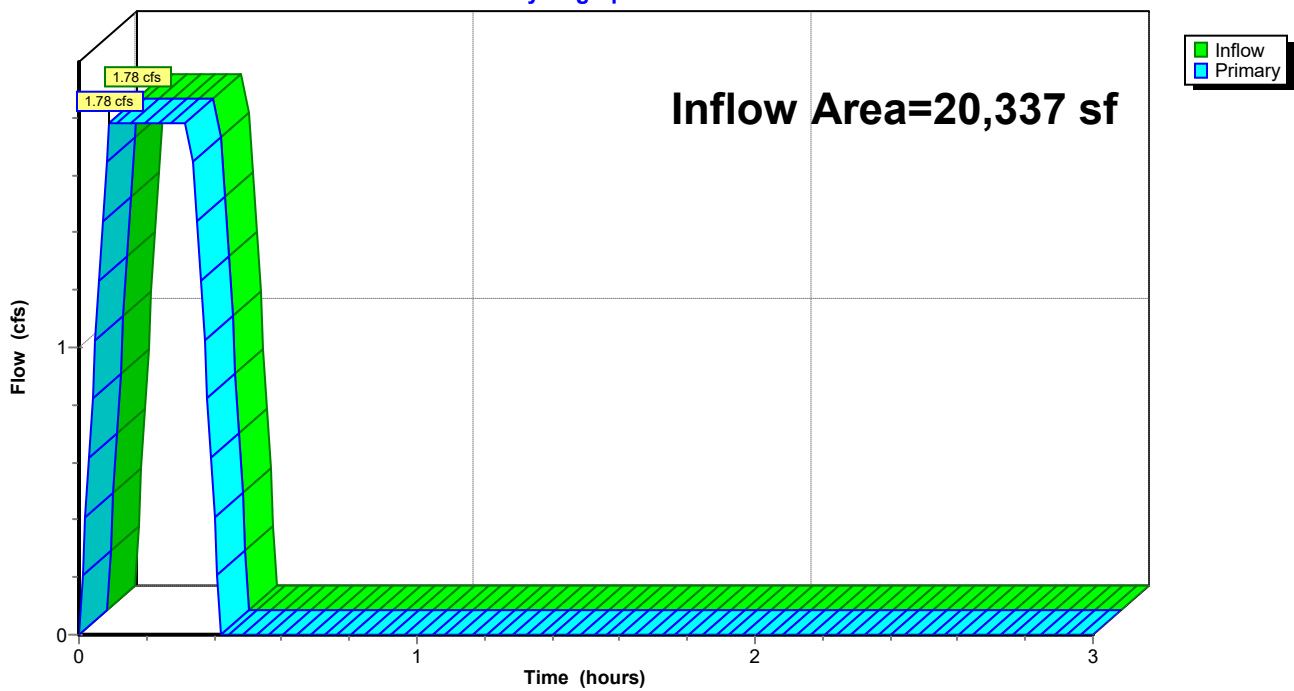

Summary for Pond CI-C2: CI - C2

Inflow Area = 54,676 sf, 67.97% Impervious, Inflow Depth = 1.25" for 25-yr event
Inflow = 4.74 cfs @ 0.09 hrs, Volume= 5,682 cf
Primary = 4.74 cfs @ 0.09 hrs, Volume= 5,682 cf, Atten= 0%, Lag= 0.0 min
Routed to Pond CI-C3 : CI - C3

Routing by Stor-Ind method, Time Span= 0.00-3.00 hrs, dt= 0.01 hrs

Pond CI-C2: CI - C2

Hydrograph

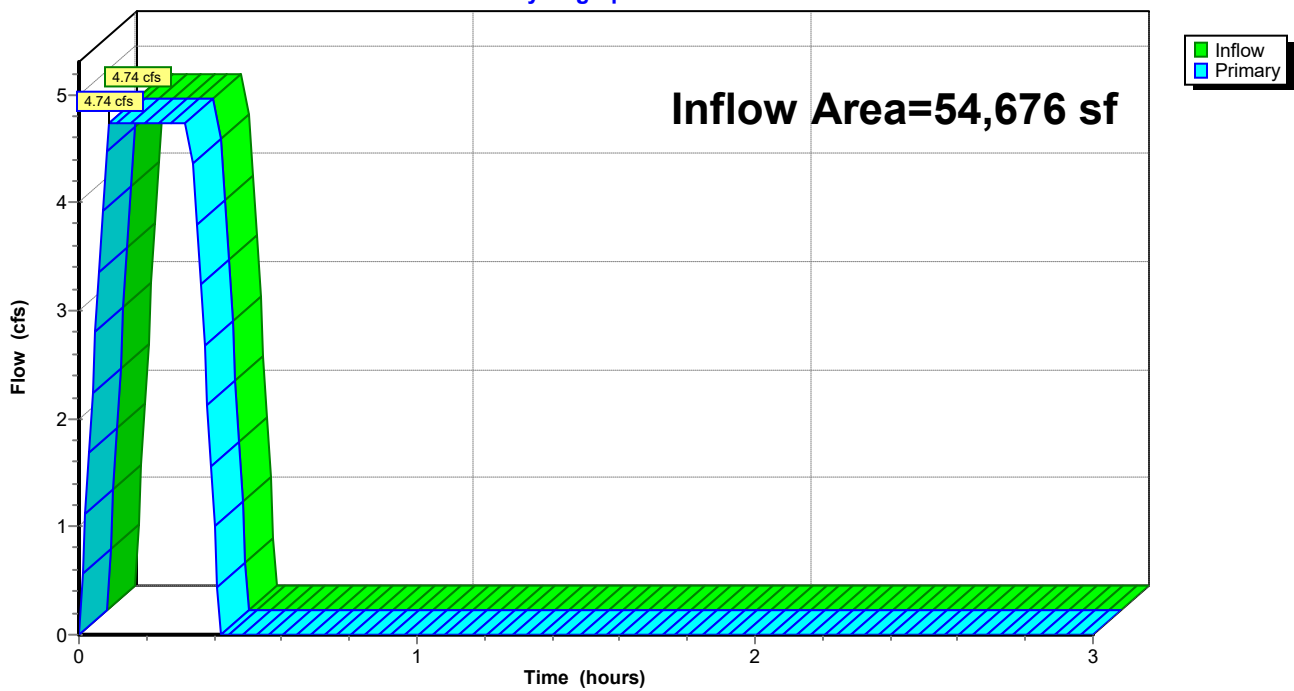

Summary for Pond CI-C3: CI - C3

Inflow Area = 69,531 sf, 63.12% Impervious, Inflow Depth = 1.20" for 25-yr event
Inflow = 5.82 cfs @ 0.09 hrs, Volume= 6,981 cf
Primary = 5.82 cfs @ 0.09 hrs, Volume= 6,981 cf, Atten= 0%, Lag= 0.0 min
Routed to Pond CI-C4 : CI - C4

Routing by Stor-Ind method, Time Span= 0.00-3.00 hrs, dt= 0.01 hrs

Pond CI-C3: CI - C3

Hydrograph

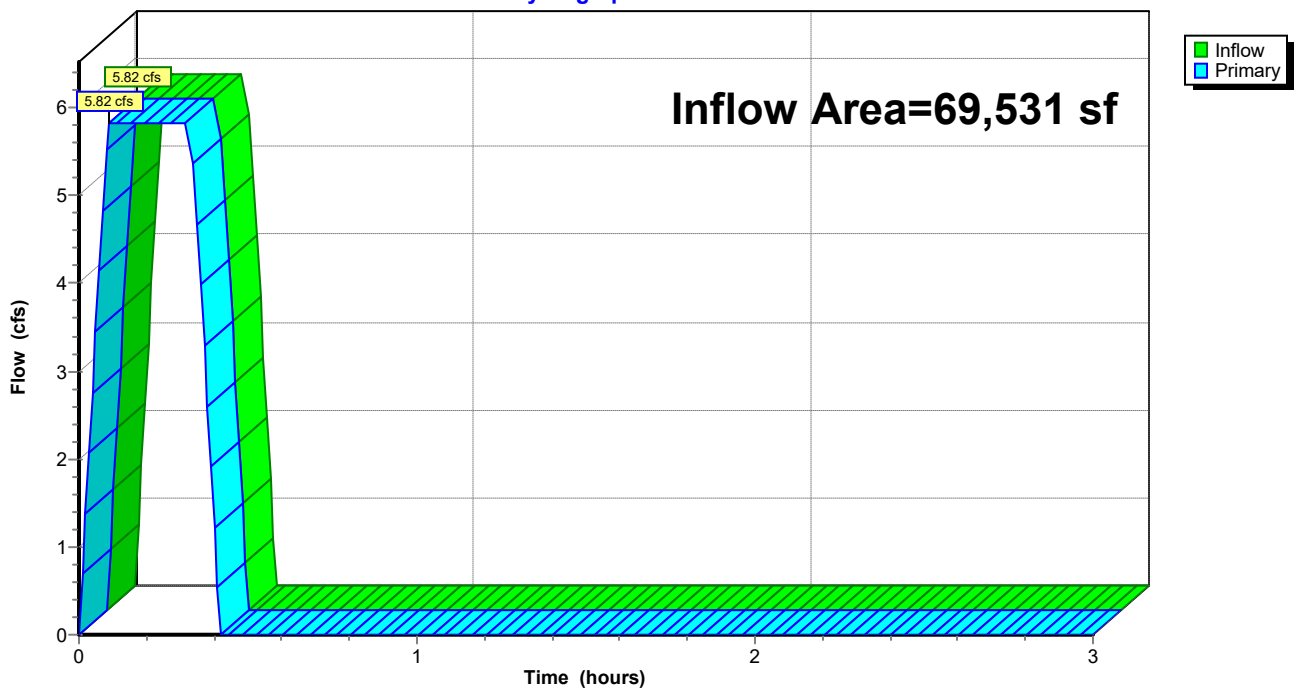

Summary for Pond CI-C4: CI - C4

Inflow Area = 76,226 sf, 64.22% Impervious, Inflow Depth = 1.22" for 25-yr event
Inflow = 6.44 cfs @ 0.10 hrs, Volume= 7,719 cf
Primary = 6.44 cfs @ 0.10 hrs, Volume= 7,719 cf, Atten= 0%, Lag= 0.0 min
Routed to Pond CI-C5 : CI - C5

Routing by Stor-Ind method, Time Span= 0.00-3.00 hrs, dt= 0.01 hrs

Pond CI-C4: CI - C4

Hydrograph

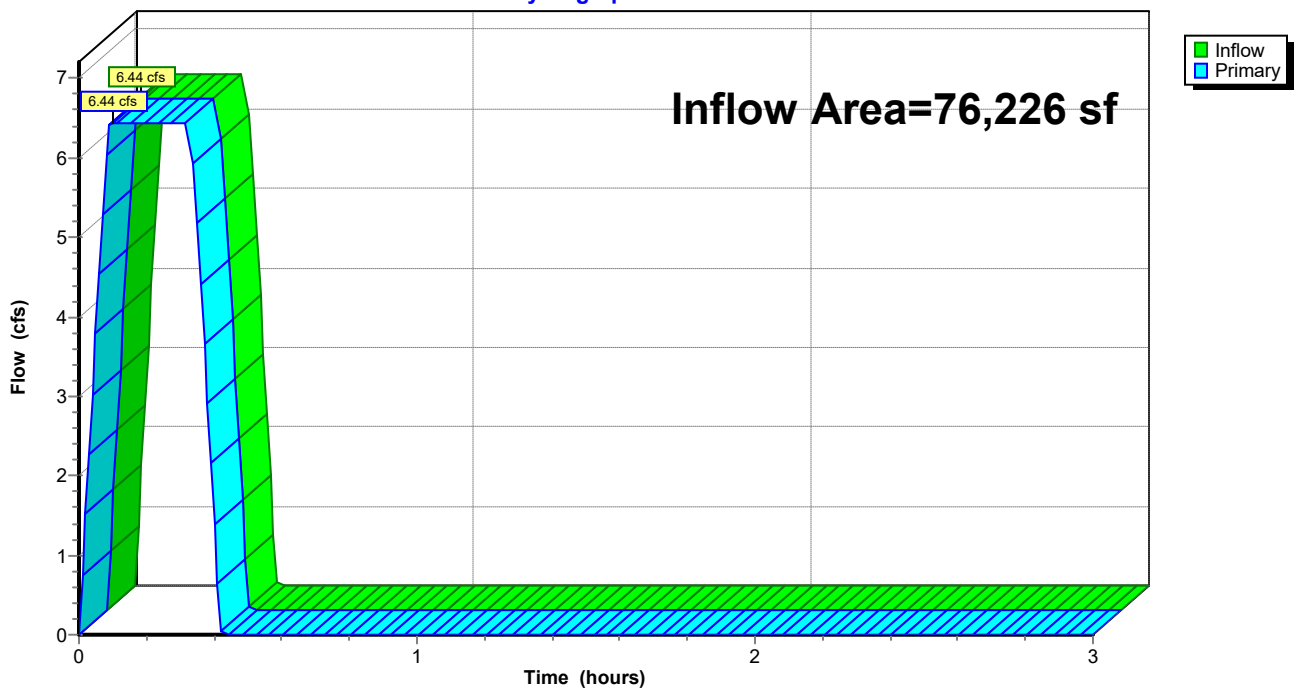

Summary for Pond CI-C5: CI - C5

Inflow Area = 79,061 sf, 65.50% Impervious, Inflow Depth = 1.23" for 25-yr event
Inflow = 6.74 cfs @ 0.10 hrs, Volume= 8,081 cf
Primary = 6.74 cfs @ 0.10 hrs, Volume= 8,081 cf, Atten= 0%, Lag= 0.0 min
Routed to Pond CI-C6 : CI - C6

Routing by Stor-Ind method, Time Span= 0.00-3.00 hrs, dt= 0.01 hrs

Pond CI-C5: CI - C5

Hydrograph

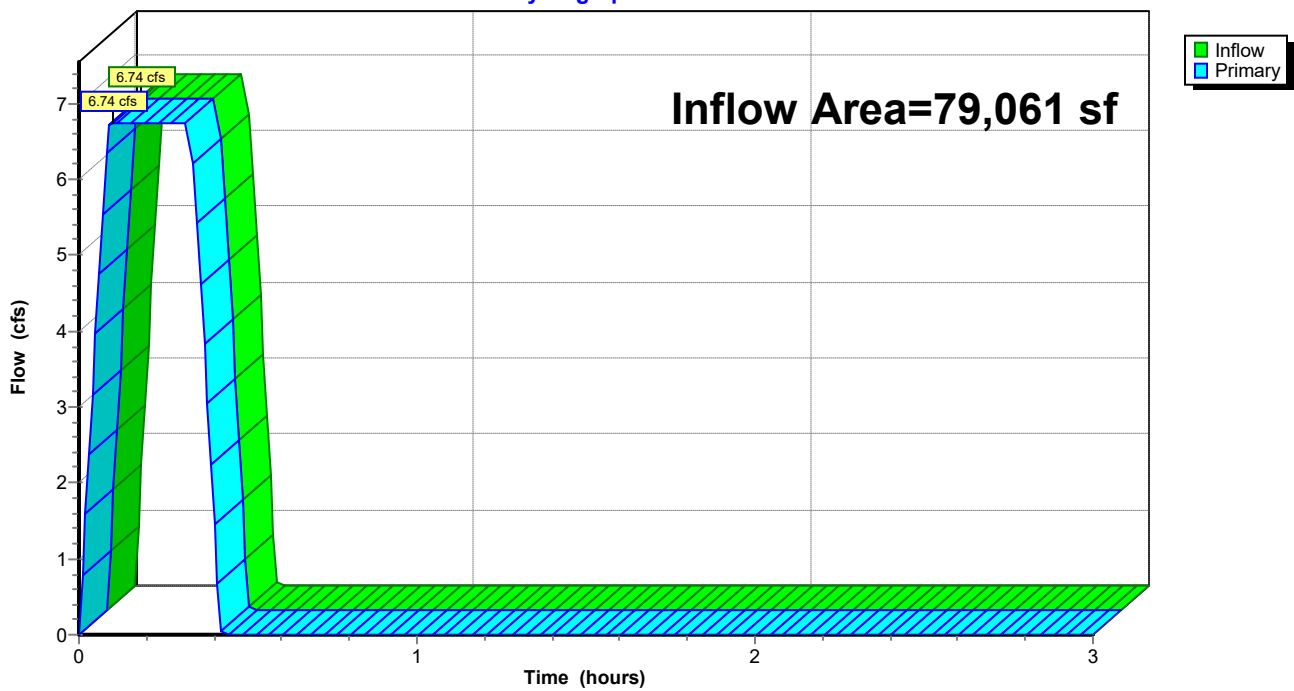

Summary for Pond CI-C6: CI - C6

Inflow Area = 96,023 sf, 66.95% Impervious, Inflow Depth = 1.24" for 25-yr event
Inflow = 8.26 cfs @ 0.10 hrs, Volume= 9,911 cf
Primary = 8.26 cfs @ 0.10 hrs, Volume= 9,911 cf, Atten= 0%, Lag= 0.0 min
Routed to Pond CI-C7 : CI - C7

Routing by Stor-Ind method, Time Span= 0.00-3.00 hrs, dt= 0.01 hrs

Pond CI-C6: CI - C6

Hydrograph

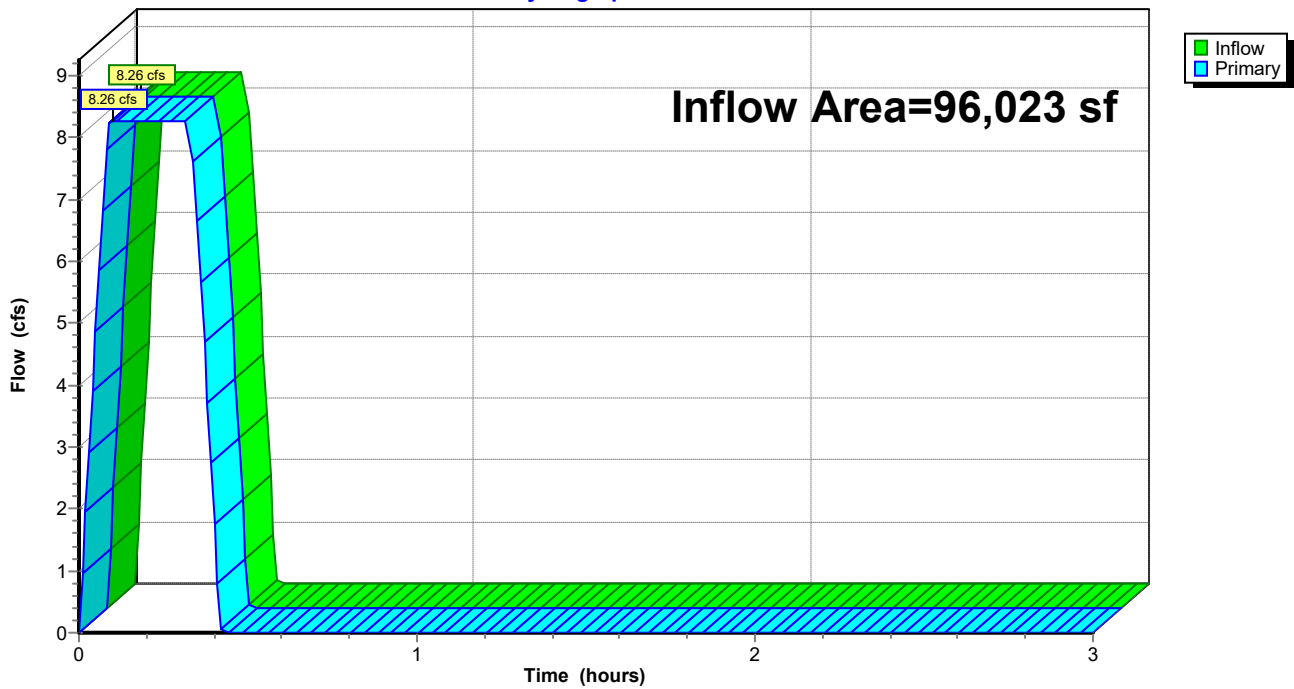

Summary for Pond CI-C7: CI - C7

Inflow Area = 133,272 sf, 67.70% Impervious, Inflow Depth = 1.25" for 25-yr event
Inflow = 11.54 cfs @ 0.10 hrs, Volume= 13,844 cf
Primary = 11.54 cfs @ 0.10 hrs, Volume= 13,844 cf, Atten= 0%, Lag= 0.0 min
Routed to Pond DP : Existing North Detention Pond

Routing by Stor-Ind method, Time Span= 0.00-3.00 hrs, dt= 0.01 hrs

Pond CI-C7: CI - C7

Hydrograph

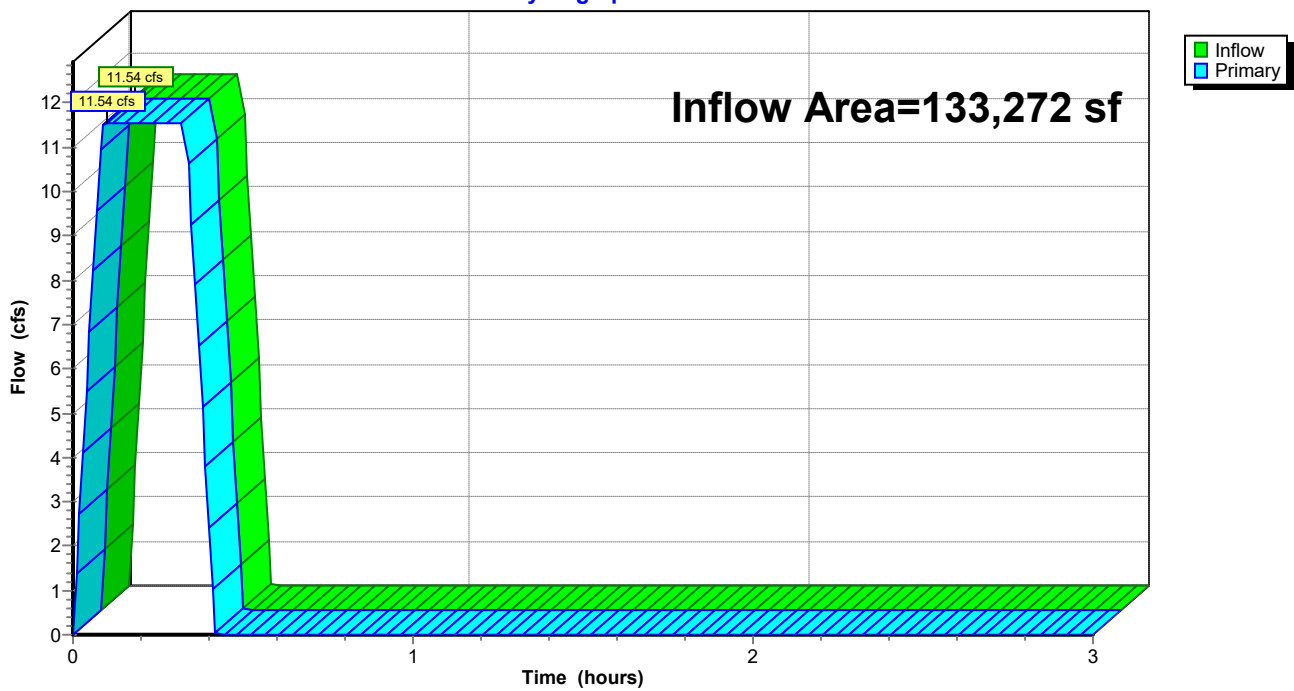

Summary for Pond CI-D1: CI - D1

Inflow Area = 1,597 sf, 100.00% Impervious, Inflow Depth = 1.53" for 25-yr event
Inflow = 0.17 cfs @ 0.09 hrs, Volume= 204 cf
Primary = 0.17 cfs @ 0.09 hrs, Volume= 204 cf, Atten= 0%, Lag= 0.0 min
Routed to Pond CI-D2 : CI - D2

Routing by Stor-Ind method, Time Span= 0.00-3.00 hrs, dt= 0.01 hrs

Pond CI-D1: CI - D1

Hydrograph

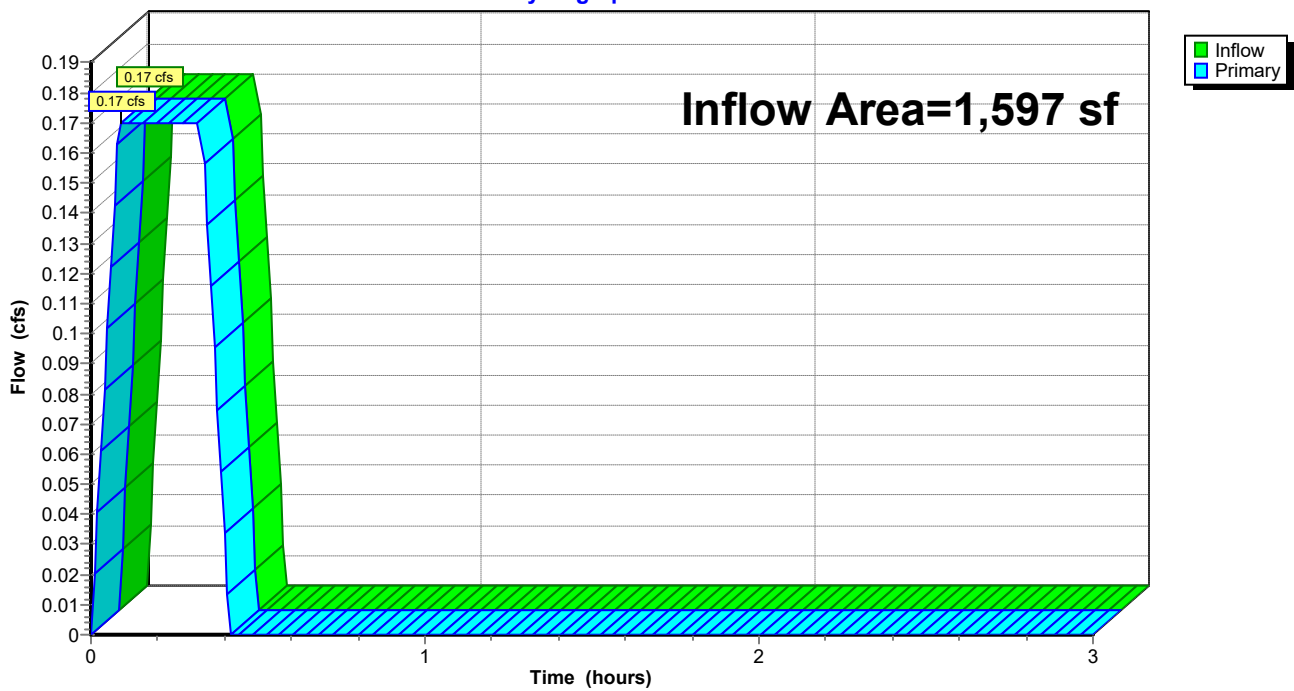

Summary for Pond CI-D2: CI - D2

Inflow Area = 3,145 sf, 100.00% Impervious, Inflow Depth = 1.53" for 25-yr event
Inflow = 0.33 cfs @ 0.09 hrs, Volume= 401 cf
Primary = 0.33 cfs @ 0.09 hrs, Volume= 401 cf, Atten= 0%, Lag= 0.0 min
Routed to Pond CI-C6 : CI - C6

Routing by Stor-Ind method, Time Span= 0.00-3.00 hrs, dt= 0.01 hrs

Pond CI-D2: CI - D2

Hydrograph

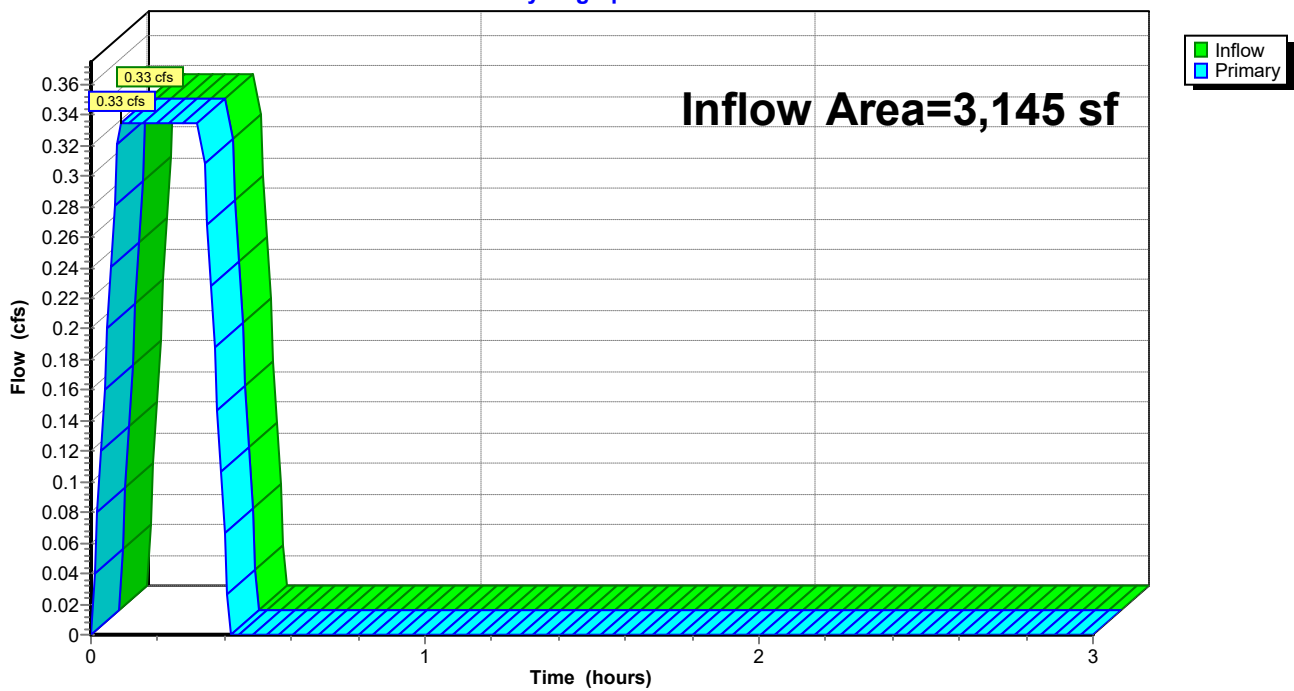

Summary for Pond CI-E1: CI - E1

Inflow Area = 5,408 sf, 77.35% Impervious, Inflow Depth = 1.34" for 25-yr event
Inflow = 0.50 cfs @ 0.09 hrs, Volume= 603 cf
Primary = 0.50 cfs @ 0.09 hrs, Volume= 603 cf, Atten= 0%, Lag= 0.0 min
Routed to Pond CI-E2 : CI - E2

Routing by Stor-Ind method, Time Span= 0.00-3.00 hrs, dt= 0.01 hrs

Pond CI-E1: CI - E1

Hydrograph

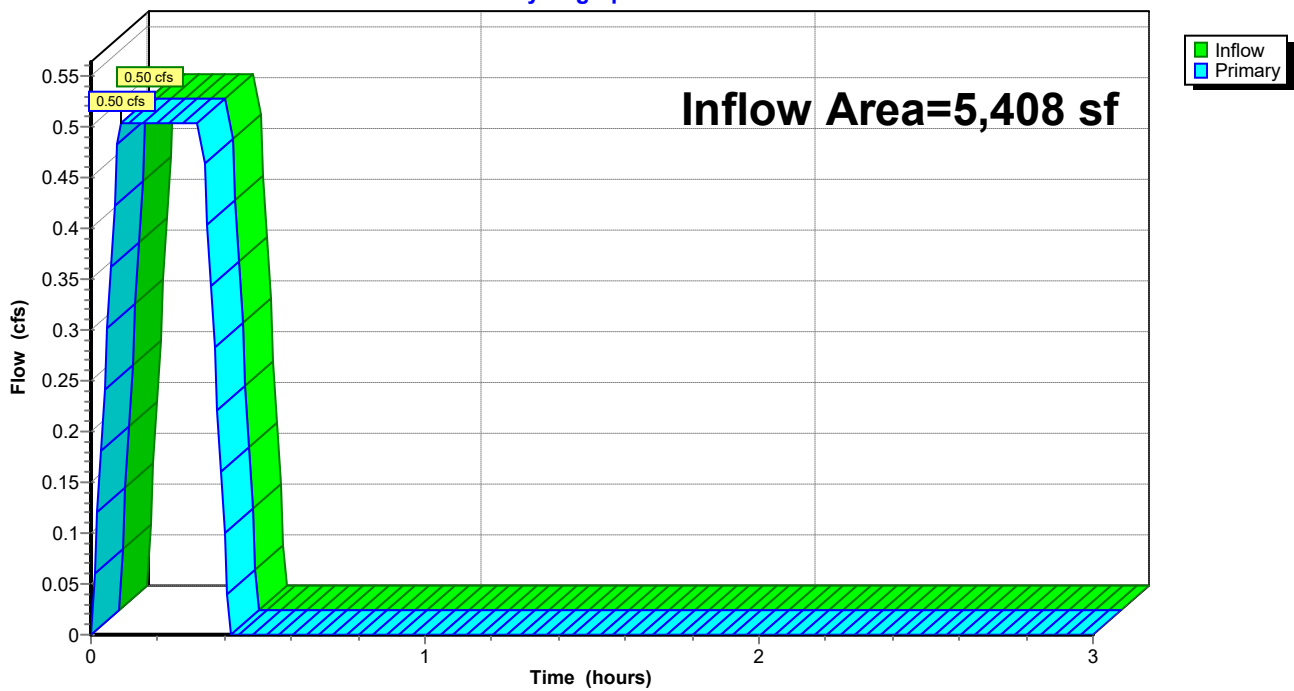

Summary for Pond CI-E2: CI - E2

Inflow Area = 11,591 sf, 64.62% Impervious, Inflow Depth = 1.22" for 25-yr event
Inflow = 0.98 cfs @ 0.09 hrs, Volume= 1,176 cf
Primary = 0.98 cfs @ 0.09 hrs, Volume= 1,176 cf, Atten= 0%, Lag= 0.0 min
Routed to Pond CI-C7 : CI - C7

Routing by Stor-Ind method, Time Span= 0.00-3.00 hrs, dt= 0.01 hrs

Pond CI-E2: CI - E2

Hydrograph

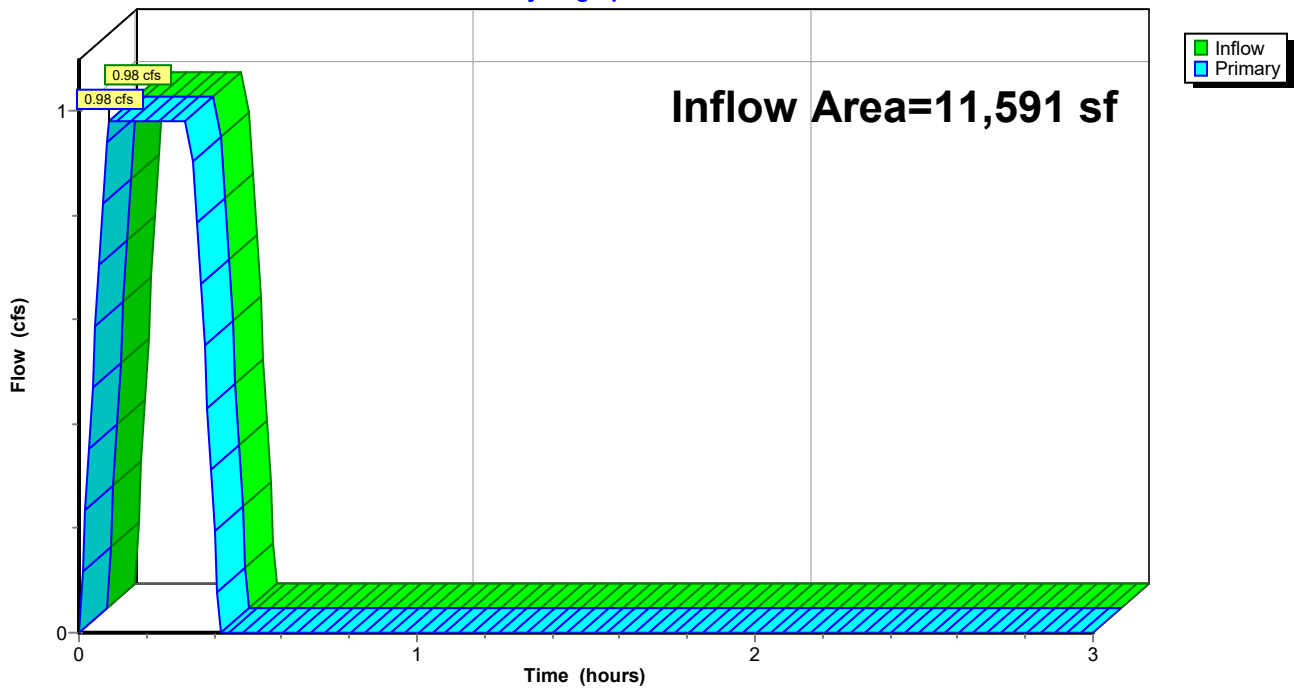

Goddard

AR - Little Rock 25-yr Duration=20 min, Inten=4.84 in/hr

Prepared by Phillip Lewis Engineering

Printed 3/25/2026

HydroCAD® 10.20-5c s/n 12520 © 2023 HydroCAD Software Solutions LLC

Summary for Pond DP: Existing North Detention Pond

Inflow Area = 322,783 sf, 53.09% Impervious, Inflow Depth = 1.13" for 25-yr event
 Inflow = 25.38 cfs @ 0.27 hrs, Volume= 30,442 cf
 Outflow = 11.34 cfs @ 0.39 hrs, Volume= 30,442 cf, Atten= 55%, Lag= 7.1 min
 Primary = 11.34 cfs @ 0.39 hrs, Volume= 30,442 cf
 Routed to Link FINAL : APPROX DISCHARGE

Routing by Stor-Ind method, Time Span= 0.00-3.00 hrs, dt= 0.01 hrs
 Peak Elev= 383.07' @ 0.39 hrs Storage= 18,646 cf

Plug-Flow detention time= 19.8 min calculated for 30,341 cf (100% of inflow)
 Center-of-Mass det. time= 20.0 min (33.5 - 13.5)

Volume	Invert	Avail.Storage	Storage Description
#1	381.17'	72,742 cf	Custom Stage Data Listed below

Elevation (feet)	Inc.Store (cubic-feet)	Cum.Store (cubic-feet)
381.17	0	0
381.50	200	200
382.00	1,825	2,025
382.50	5,265	7,290
383.00	9,300	16,590
383.50	13,733	30,323
384.00	18,578	48,901
384.50	23,841	72,742

Device	Routing	Invert	Outlet Devices
#1	Primary	384.16'	5.0' long Sharp-Crested Rectangular Weir 2 End Contraction(s)
#2	Primary	381.17'	1.7' long Sharp-Crested Rectangular Weir 2 End Contraction(s)

Primary OutFlow Max=11.34 cfs @ 0.39 hrs HW=383.07' (Free Discharge)

↑ **1=Sharp-Crested Rectangular Weir** (Controls 0.00 cfs)

└ **2=Sharp-Crested Rectangular Weir** (Weir Controls 11.34 cfs @ 4.51 fps)

Pond DP: Existing North Detention Pond

Hydrograph

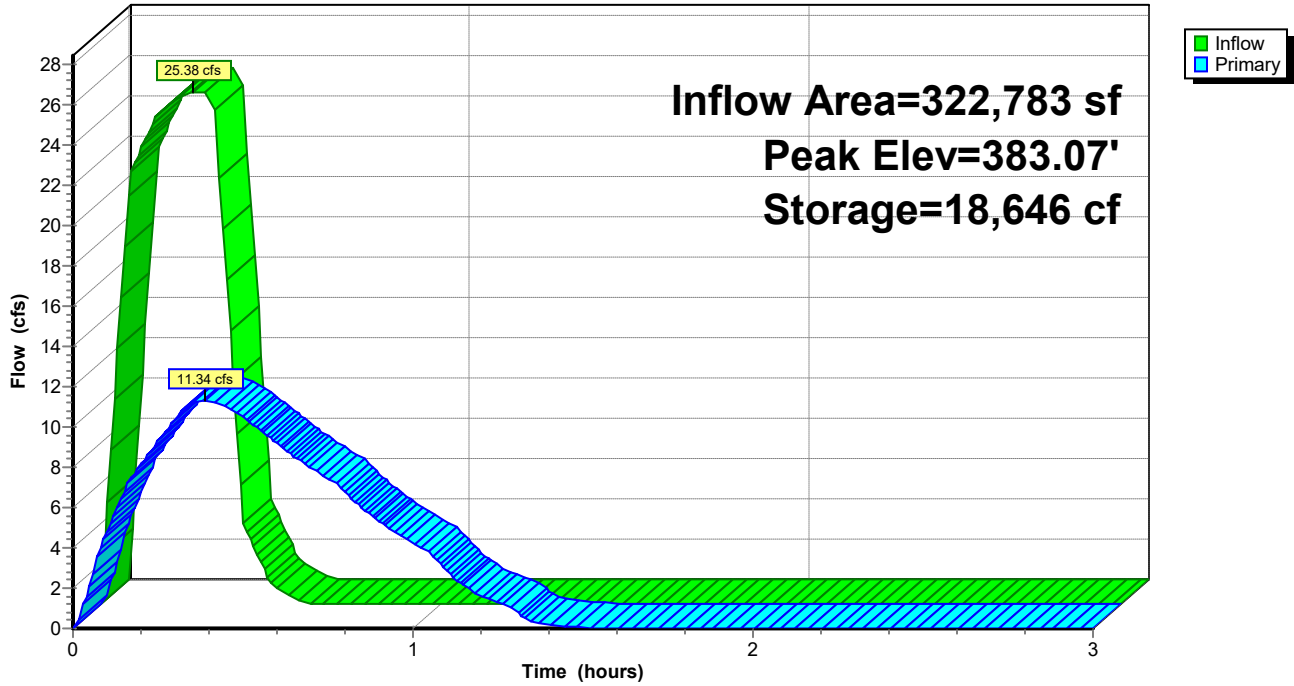

Summary for Pond JB-A2: JB - A2

Inflow Area = 50,937 sf, 59.76% Impervious, Inflow Depth = 1.25" for 25-yr event
Inflow = 4.41 cfs @ 0.17 hrs, Volume= 5,289 cf
Primary = 4.41 cfs @ 0.17 hrs, Volume= 5,289 cf, Atten= 0%, Lag= 0.0 min
Routed to Pond CI-A3 : CI - A3

Routing by Stor-Ind method, Time Span= 0.00-3.00 hrs, dt= 0.01 hrs

Pond JB-A2: JB - A2

Hydrograph

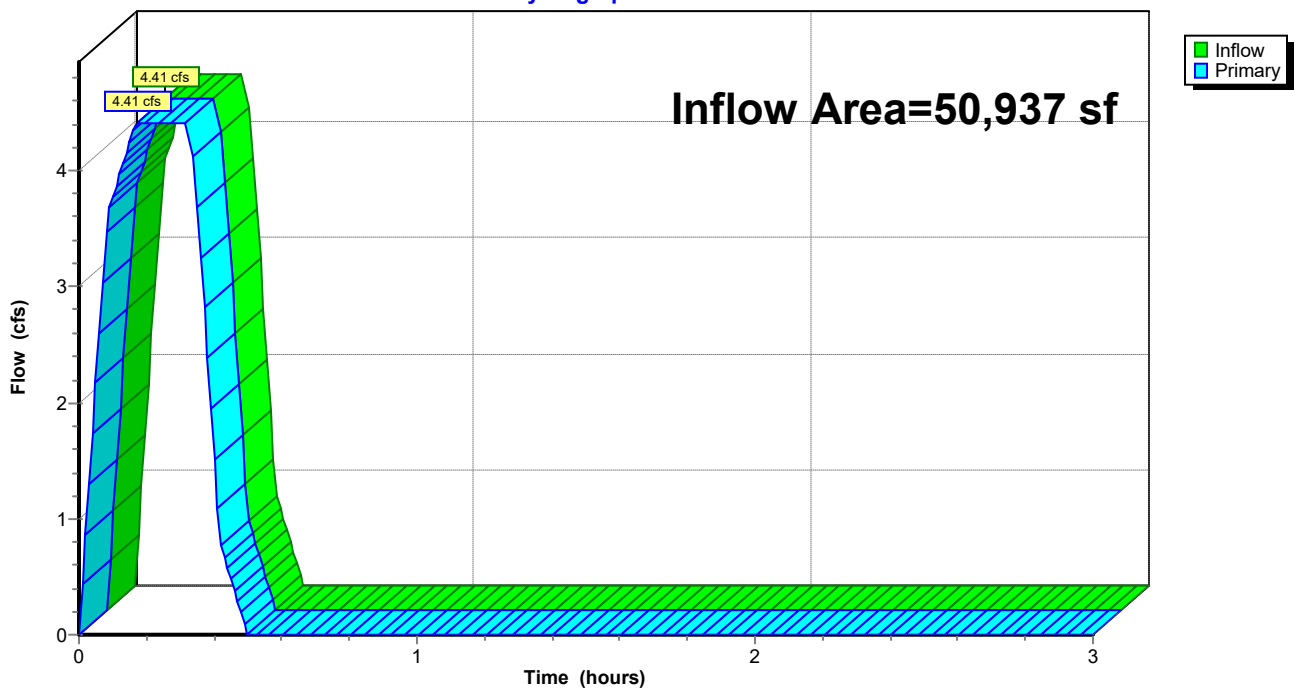

Summary for Link FINAL: APPROX DISCHARGE

Inflow Area = 509,184 sf, 38.62% Impervious, Inflow Depth = 1.04" for 25-yr event
Inflow = 22.19 cfs @ 0.33 hrs, Volume= 43,951 cf
Primary = 22.19 cfs @ 0.33 hrs, Volume= 43,951 cf, Atten= 0%, Lag= 0.0 min

Primary outflow = Inflow, Time Span= 0.00-3.00 hrs, dt= 0.01 hrs

Link FINAL: APPROX DISCHARGE

Hydrograph

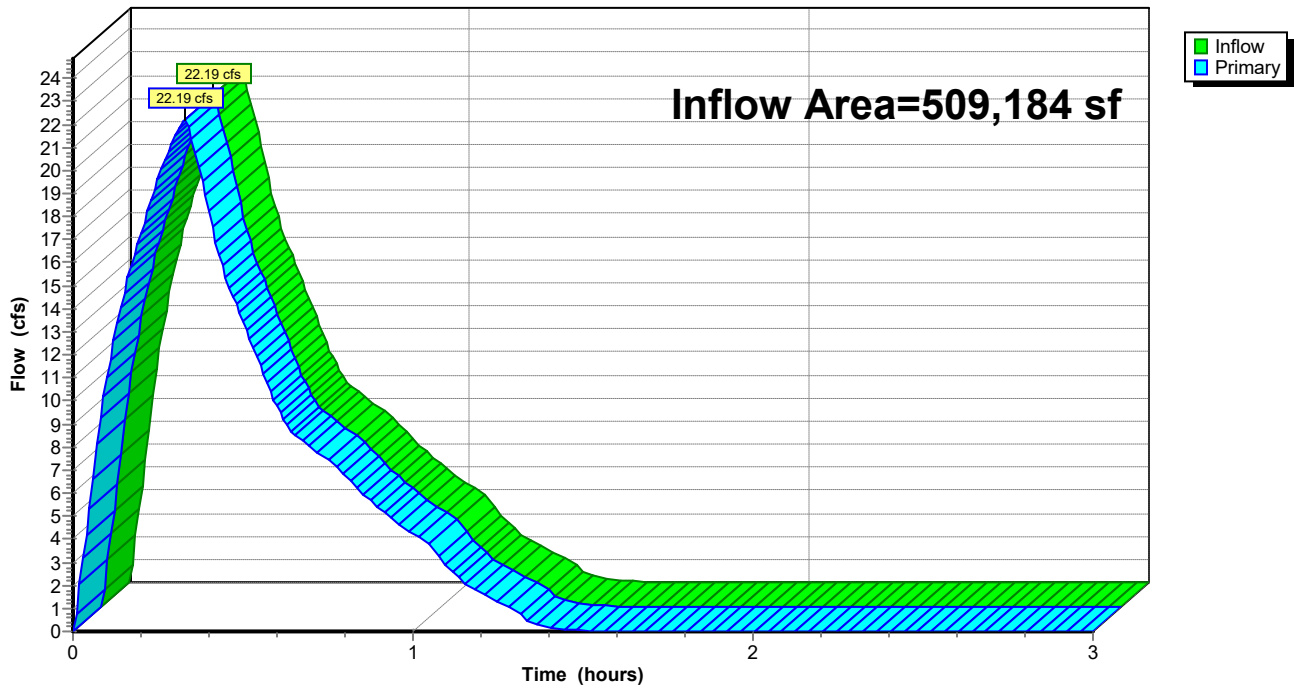

Goddard

AR - Little Rock 100-yr Duration=20 min, Inten=5.78 in/hr

Prepared by Phillip Lewis Engineering

Printed 3/25/2026

HydroCAD® 10.20-5c s/n 12520 © 2023 HydroCAD Software Solutions LLC

Summary for Subcatchment B1: Drainage Basin B1

Runoff = 5.30 cfs @ 0.31 hrs, Volume= 6,363 cf, Depth= 1.02"

Routed to Link FINAL : APPROX DISCHARGE

Runoff by Rational method, Rise/Fall=1.0/1.0 xTc, Time Span= 0.00-3.00 hrs, dt= 0.01 hrs

AR - Little Rock 100-yr Duration=20 min, Inten=5.78 in/hr

Area (sf)	C	Description
9,241	0.51	Sod Yard
602	0.95	Paving, Sidewalks
64,924	0.53	Undeveloped
74,767	0.53	Weighted Average
74,165		99.19% Pervious Area
602		0.81% Impervious Area

Tc (min)	Length (feet)	Slope (ft/ft)	Velocity (ft/sec)	Capacity (cfs)	Description
0.1	6	0.0180	0.86		Sheet Flow, Sheet Flow Smooth surfaces n= 0.011 P2= 4.19"
2.6	25	0.1920	0.16		Sheet Flow, Sheet Flow Grass: Bermuda n= 0.410 P2= 4.19"
11.9	75	0.0370	0.11		Sheet Flow, Sheet Flow Grass: Bermuda n= 0.410 P2= 4.19"
0.7	58	0.0370	1.35		Shallow Concentrated Flow, Concentrated Flow Short Grass Pasture Kv= 7.0 fps
1.6	141	0.0420	1.43		Shallow Concentrated Flow, Concentrated Flow Short Grass Pasture Kv= 7.0 fps
0.7	60	0.0400	1.40		Shallow Concentrated Flow, Concentrated Flow Short Grass Pasture Kv= 7.0 fps
0.9	77	0.0420	1.43		Shallow Concentrated Flow, Concentrated Flow Short Grass Pasture Kv= 7.0 fps
18.5	442	Total			

Subcatchment B1: Drainage Basin B1

Hydrograph

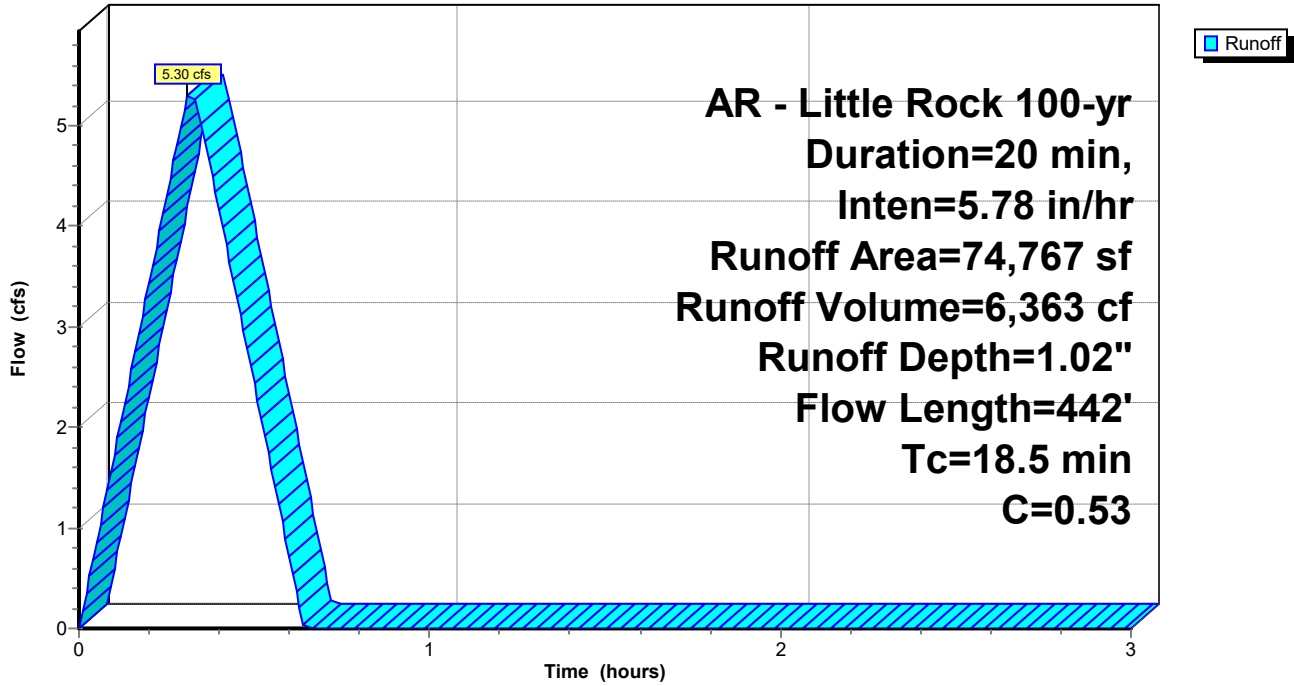

Goddard

Prepared by Phillip Lewis Engineering

HydroCAD® 10.20-5c s/n 12520 © 2023 HydroCAD Software Solutions LLC

AR - Little Rock 100-yr Duration=20 min, Inten=5.78 in/hr

Printed 3/25/2026

Summary for Subcatchment B2: Drainage Basin B2

Runoff = 0.47 cfs @ 0.10 hrs, Volume= 564 cf, Depth= 1.00"
 Routed to Link FINAL : APPROX DISCHARGE

Runoff by Rational method, Rise/Fall=1.0/1.0 xTc, Time Span= 0.00-3.00 hrs, dt= 0.01 hrs
 AR - Little Rock 100-yr Duration=20 min, Inten=5.78 in/hr

Area (sf)	C	Description
6,595	0.51	Sod Yard
167	0.95	Paving, Sidewalks
6,762	0.52	Weighted Average
6,595		97.53% Pervious Area
167		2.47% Impervious Area

Tc (min)	Length (feet)	Slope (ft/ft)	Velocity (ft/sec)	Capacity (cfs)	Description
0.1	6	0.0180	0.86		Sheet Flow, Sheet Flow Smooth surfaces n= 0.011 P2= 4.19"
5.7	55	0.1240	0.16		Sheet Flow, Sheet Flow Grass: Bermuda n= 0.410 P2= 4.19"
5.8	61	Total			

Subcatchment B2: Drainage Basin B2

Hydrograph

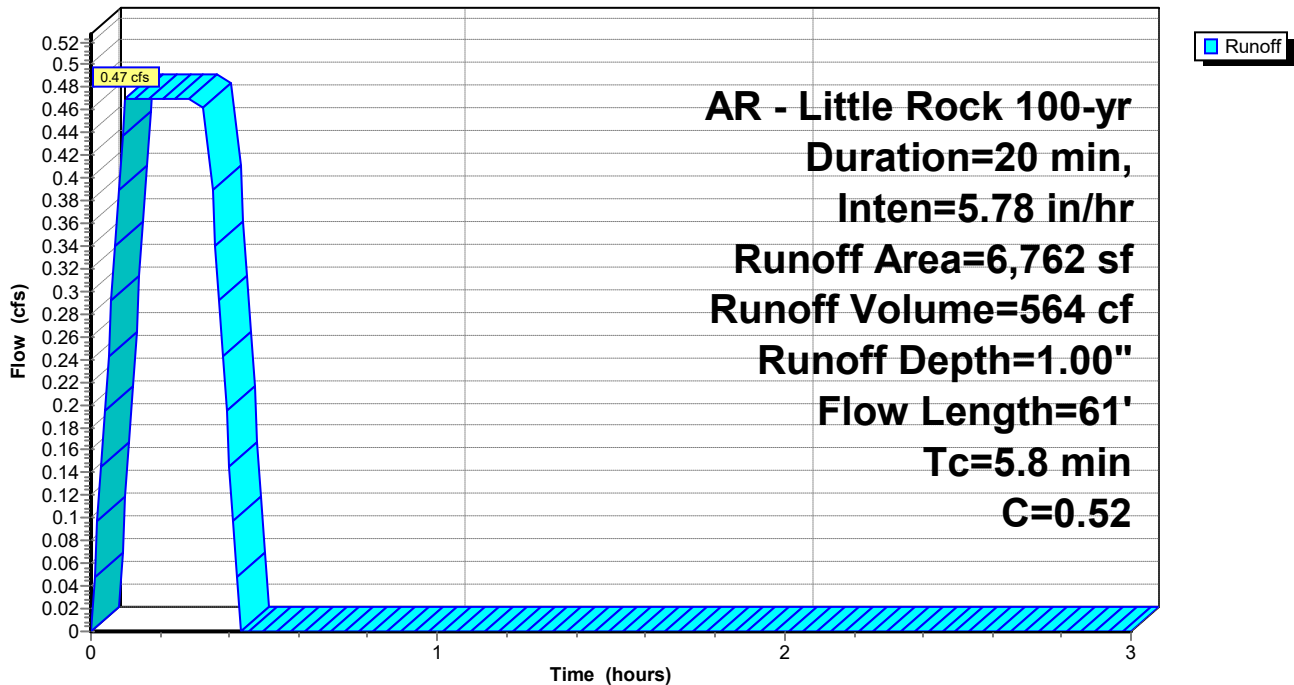

Summary for Subcatchment B3: Drainage Basin B3

Runoff = 3.12 cfs @ 0.26 hrs, Volume= 3,741 cf, Depth= 1.35"
 Routed to Link FINAL : APPROX DISCHARGE

Runoff by Rational method, Rise/Fall=1.0/1.0 xTc, Time Span= 0.00-3.00 hrs, dt= 0.01 hrs
 AR - Little Rock 100-yr Duration=20 min, Inten=5.78 in/hr

Area (sf)	C	Description
18,730	0.51	Sod Yard
14,559	0.95	Paving, Sidewalks
33,289	0.70	Weighted Average
18,730		56.26% Pervious Area
14,559		43.74% Impervious Area

Tc (min)	Length (feet)	Slope (ft/ft)	Velocity (ft/sec)	Capacity (cfs)	Description
4.9	47	0.1300	0.16		Sheet Flow, Sheet Flow Grass: Bermuda n= 0.410 P2= 4.19"
6.9	53	0.0730	0.13		Sheet Flow, Sheet Flow Grass: Bermuda n= 0.410 P2= 4.19"
0.0	11	0.0940	4.60		Shallow Concentrated Flow, Concentrated Flow Grassed Waterway Kv= 15.0 fps
0.4	53	0.0120	2.22		Shallow Concentrated Flow, Concentrated Flow Paved Kv= 20.3 fps
0.5	59	0.0100	2.03		Shallow Concentrated Flow, Concentrated Flow Paved Kv= 20.3 fps
0.5	47	0.0070	1.70		Shallow Concentrated Flow, Concentrated Flow Paved Kv= 20.3 fps
0.5	56	0.0070	1.70		Shallow Concentrated Flow, Concentrated Flow Paved Kv= 20.3 fps
0.2	38	0.0160	2.57		Shallow Concentrated Flow, Concentrated Flow Paved Kv= 20.3 fps
0.2	30	0.0190	2.80		Shallow Concentrated Flow, Concentrated Flow Paved Kv= 20.3 fps
1.3	216	0.0190	2.80		Shallow Concentrated Flow, Concentrated Flow Paved Kv= 20.3 fps
15.4	610	Total			

Subcatchment B3: Drainage Basin B3

Hydrograph

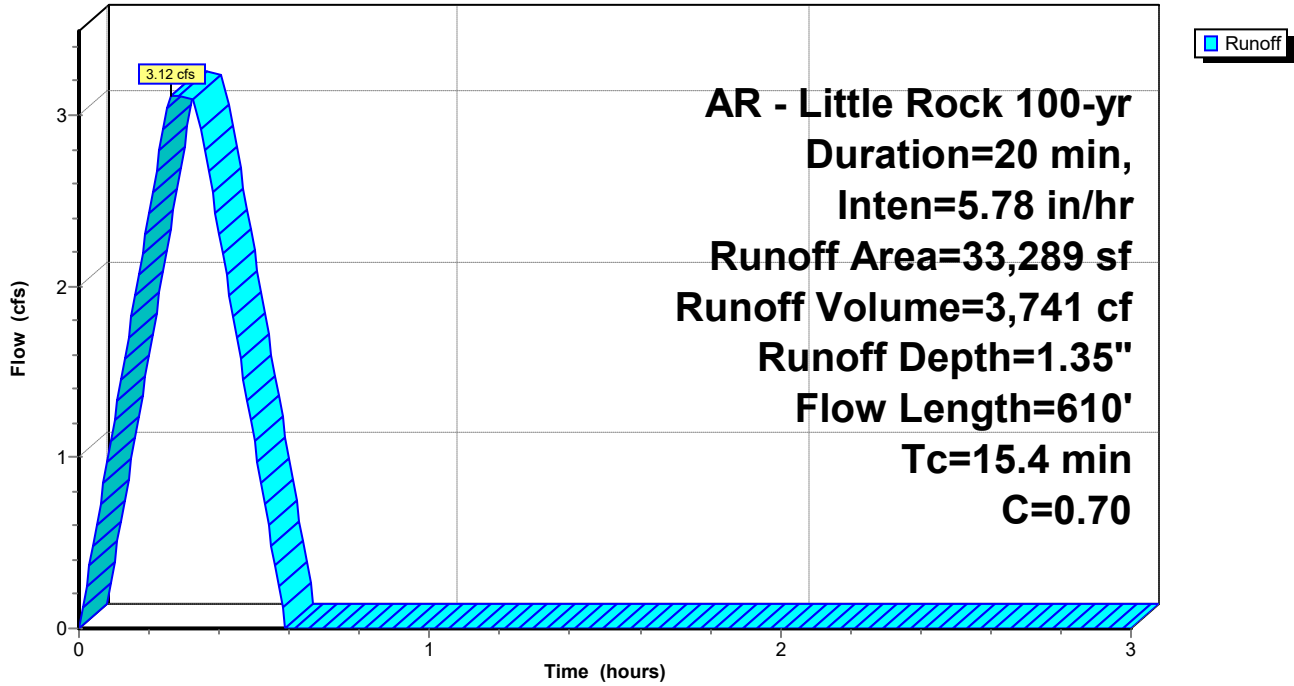

Goddard

Prepared by Phillip Lewis Engineering

HydroCAD® 10.20-5c s/n 12520 © 2023 HydroCAD Software Solutions LLC

AR - Little Rock 100-yr Duration=20 min, Inten=5.78 in/hr

Printed 3/25/2026

Summary for Subcatchment B4: Drainage Basin B4

Runoff = 2.19 cfs @ 0.09 hrs, Volume= 2,628 cf, Depth= 1.62"
 Routed to Pond CI-A1 : CI - A1

Runoff by Rational method, Rise/Fall=1.0/1.0 xTc, Time Span= 0.00-3.00 hrs, dt= 0.01 hrs
 AR - Little Rock 100-yr Duration=20 min, Inten=5.78 in/hr

Area (sf)	C	Description
4,916	0.51	Sod Yard
14,577	0.95	Paving, Sidewalks
19,493	0.84	Weighted Average
4,916		25.22% Pervious Area
14,577		74.78% Impervious Area

Tc (min)	Length (feet)	Slope (ft/ft)	Velocity (ft/sec)	Capacity (cfs)	Description
0.4	31	0.0230	1.32		Sheet Flow, Sheet Flow Smooth surfaces n= 0.011 P2= 4.19"
0.2	18	0.0250	1.22		Sheet Flow, Sheet Flow Smooth surfaces n= 0.011 P2= 4.19"
0.3	28	0.0450	1.69		Sheet Flow, Sheet Flow Smooth surfaces n= 0.011 P2= 4.19"
0.4	72	0.0250	3.21		Shallow Concentrated Flow, Concentrated Flow Paved Kv= 20.3 fps
0.1	18	0.0170	2.65		Shallow Concentrated Flow, Concentrated Flow Paved Kv= 20.3 fps
0.3	51	0.0170	2.65		Shallow Concentrated Flow, Concentrated Flow Paved Kv= 20.3 fps
0.1	16	0.0170	2.65		Shallow Concentrated Flow, Concentrated Flow Paved Kv= 20.3 fps
0.0	8	0.0430	4.21		Shallow Concentrated Flow, Concentrated Flow Paved Kv= 20.3 fps
0.0	7	0.0580	4.89		Shallow Concentrated Flow, Concentrated Flow Paved Kv= 20.3 fps
3.2					Direct Entry, Overland Concentrated Flow (Min)
5.0	249	Total			

Subcatchment B4: Drainage Basin B4

Hydrograph

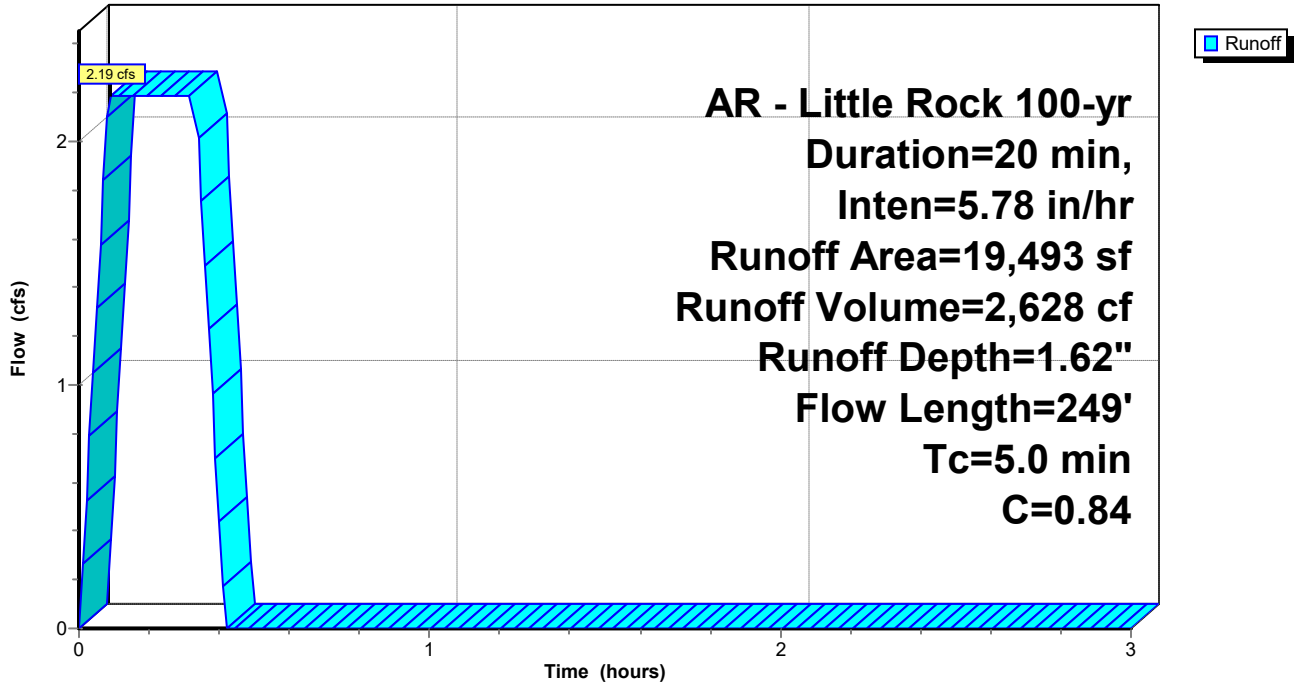

Summary for Subcatchment B5: Drainage Basin B5

Runoff = 1.18 cfs @ 0.09 hrs, Volume= 1,414 cf, Depth= 1.83"
 Routed to Pond JB-A2 : JB - A2

Runoff by Rational method, Rise/Fall=1.0/1.0 xTc, Time Span= 0.00-3.00 hrs, dt= 0.01 hrs
 AR - Little Rock 100-yr Duration=20 min, Inten=5.78 in/hr

Area (sf)	C	Description
9,275	0.95	Roof
9,275		100.00% Impervious Area

Tc (min)	Length (feet)	Slope (ft/ft)	Velocity (ft/sec)	Capacity (cfs)	Description
5.0					Direct Entry, Concentrated Flow (Min)

Subcatchment B5: Drainage Basin B5

Hydrograph

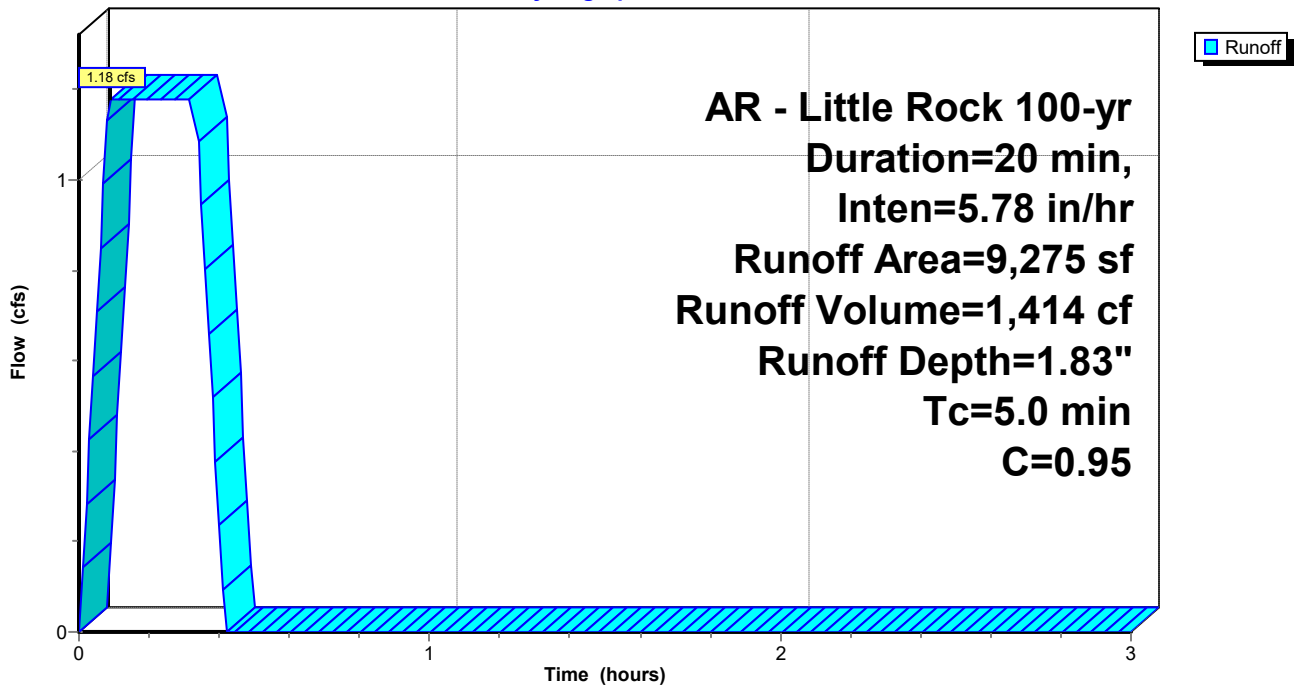

Goddard

Prepared by Phillip Lewis Engineering

HydroCAD® 10.20-5c s/n 12520 © 2023 HydroCAD Software Solutions LLC

AR - Little Rock 100-yr Duration=20 min, Inten=5.78 in/hr

Printed 3/25/2026

Summary for Subcatchment B6: Drainage Basin B6

Runoff = 0.24 cfs @ 0.09 hrs, Volume= 288 cf, Depth= 1.83"
 Routed to Pond CI-A3 : CI - A3

Runoff by Rational method, Rise/Fall=1.0/1.0 xTc, Time Span= 0.00-3.00 hrs, dt= 0.01 hrs
 AR - Little Rock 100-yr Duration=20 min, Inten=5.78 in/hr

Area (sf)	C	Description
0	0.51	Sod Yard
1,887	0.95	Paving, Sidewalks
1,887	0.95	Weighted Average
1,887		100.00% Impervious Area

Tc (min)	Length (feet)	Slope (ft/ft)	Velocity (ft/sec)	Capacity (cfs)	Description
0.4	31	0.0230	1.32		Sheet Flow, Sheet Flow Smooth surfaces n= 0.011 P2= 4.19"
0.2	18	0.0250	1.22		Sheet Flow, Sheet Flow Smooth surfaces n= 0.011 P2= 4.19"
0.4	30	0.0240	1.33		Sheet Flow, Sheet Flow Smooth surfaces n= 0.011 P2= 4.19"
0.0	13	0.0860	5.95		Shallow Concentrated Flow, Concentrated Flow Paved Kv= 20.3 fps
4.0	415		1.73		Direct Entry, Overland Concentrated Flow (Min)
5.0	507	Total			

Subcatchment B6: Drainage Basin B6

Hydrograph

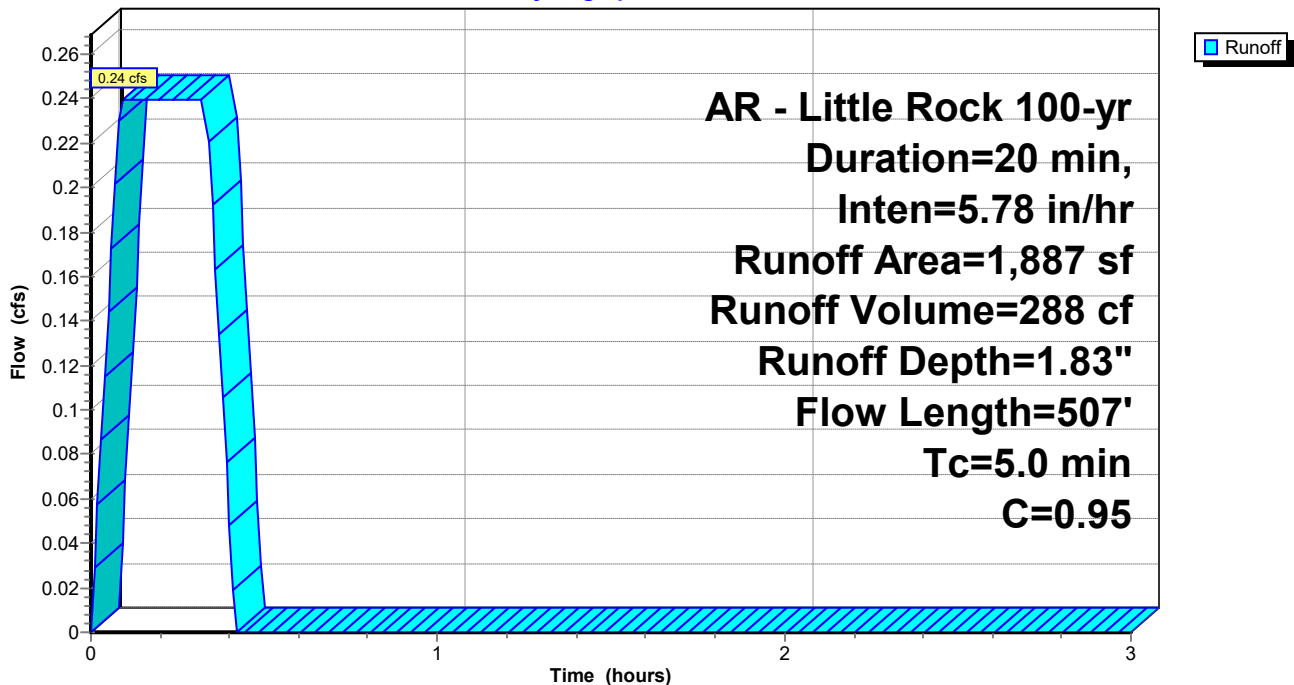

Goddard

Prepared by Phillip Lewis Engineering

HydroCAD® 10.20-5c s/n 12520 © 2023 HydroCAD Software Solutions LLC

AR - Little Rock 100-yr Duration=20 min, Inten=5.78 in/hr

Printed 3/25/2026

Summary for Subcatchment B7: Drainage Basin B7

Runoff = 1.90 cfs @ 0.17 hrs, Volume= 2,278 cf, Depth= 1.23"
 Routed to Pond CI-B2 : CI - B2

Runoff by Rational method, Rise/Fall=1.0/1.0 xTc, Time Span= 0.00-3.00 hrs, dt= 0.01 hrs
 AR - Little Rock 100-yr Duration=20 min, Inten=5.78 in/hr

Area (sf)	C	Description
15,580	0.51	Sod Yard
6,589	0.95	Paving, Sidewalks
22,169	0.64	Weighted Average
15,580		70.28% Pervious Area
6,589		29.72% Impervious Area

Tc (min)	Length (feet)	Slope (ft/ft)	Velocity (ft/sec)	Capacity (cfs)	Description
0.2	10	0.0150	0.89		Sheet Flow, Sheet Flow Smooth surfaces n= 0.011 P2= 4.19"
9.1	93	0.0150	0.17		Sheet Flow, Sheet Flow Grass: Short n= 0.150 P2= 4.19"
0.4	40	0.0110	1.57		Shallow Concentrated Flow, Concentrated Flow Grassed Waterway Kv= 15.0 fps
0.3	33	0.0190	2.07		Shallow Concentrated Flow, Concentrated Flow Grassed Waterway Kv= 15.0 fps
0.0	6	0.0180	2.72		Shallow Concentrated Flow, Concentrated Flow Paved Kv= 20.3 fps
10.0	182	Total			

Subcatchment B7: Drainage Basin B7

Hydrograph

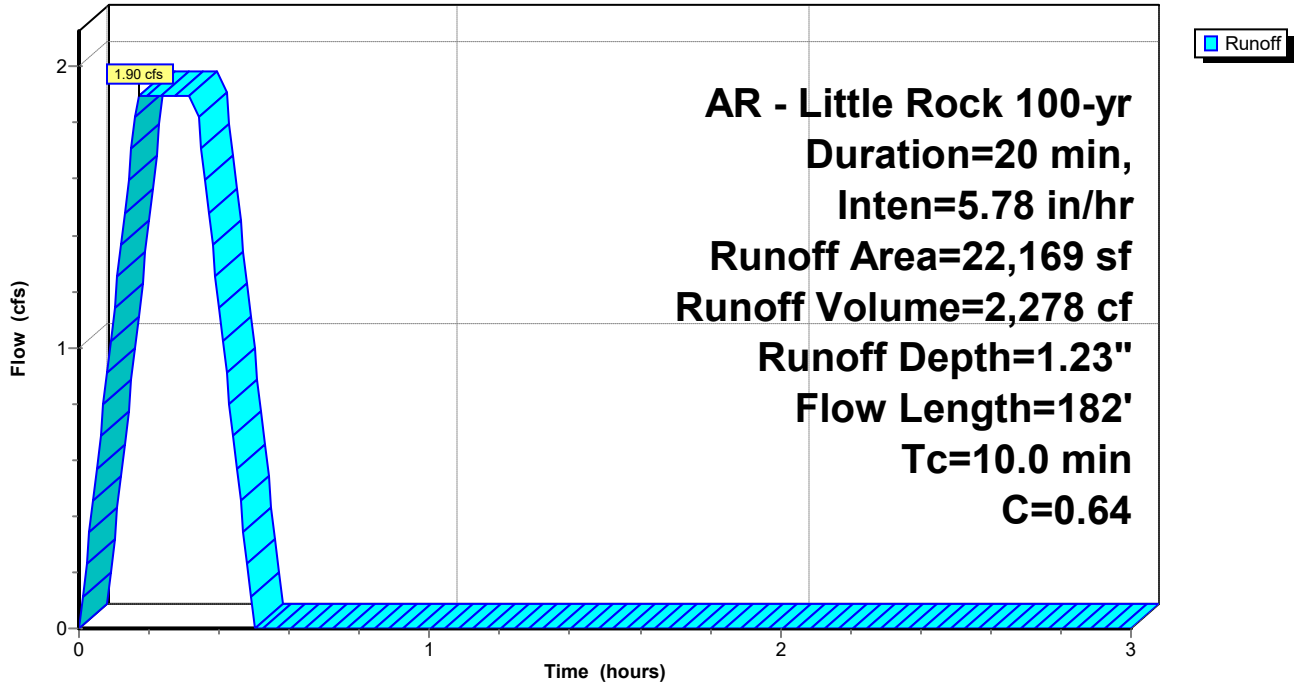

Goddard

Prepared by Phillip Lewis Engineering

HydroCAD® 10.20-5c s/n 12520 © 2023 HydroCAD Software Solutions LLC

AR - Little Rock 100-yr Duration=20 min, Inten=5.78 in/hr

Printed 3/25/2026

Summary for Subcatchment B8: Drainage Basin B8

Runoff = 1.37 cfs @ 0.24 hrs, Volume= 1,646 cf, Depth= 1.37"
 Routed to Pond CI-A4 : CI - A4

Runoff by Rational method, Rise/Fall=1.0/1.0 xTc, Time Span= 0.00-3.00 hrs, dt= 0.01 hrs
 AR - Little Rock 100-yr Duration=20 min, Inten=5.78 in/hr

Area (sf)	C	Description
7,982	0.51	Sod Yard
6,458	0.95	Paving, Sidewalks
14,440	0.71	Weighted Average
7,982		55.28% Pervious Area
6,458		44.72% Impervious Area

Tc (min)	Length (feet)	Slope (ft/ft)	Velocity (ft/sec)	Capacity (cfs)	Description
10.4	79	0.0570	0.13		Sheet Flow, Sheet Flow Grass: Bermuda n= 0.410 P2= 4.19"
3.5	21	0.0620	0.10		Sheet Flow, Sheet Flow Grass: Bermuda n= 0.410 P2= 4.19"
0.0	9	0.0620	3.73		Shallow Concentrated Flow, Concentrated Flow Grassed Waterway Kv= 15.0 fps
0.1	18	0.1080	4.93		Shallow Concentrated Flow, Concentrated Flow Grassed Waterway Kv= 15.0 fps
14.0	127	Total			

Subcatchment B8: Drainage Basin B8

Hydrograph

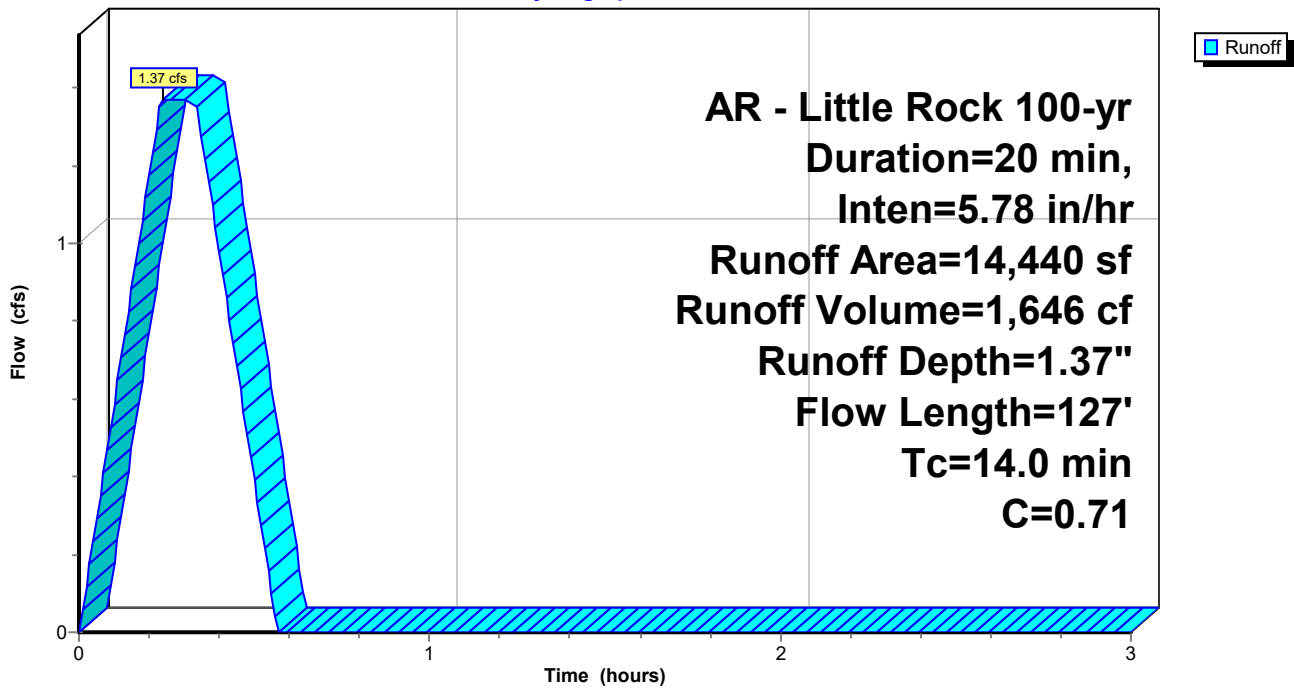

Goddard

Prepared by Phillip Lewis Engineering

HydroCAD® 10.20-5c s/n 12520 © 2023 HydroCAD Software Solutions LLC

AR - Little Rock 100-yr Duration=20 min, Inten=5.78 in/hr

Printed 3/25/2026

Summary for Subcatchment C1: Drainage Basin C1

Runoff = 2.12 cfs @ 0.09 hrs, Volume= 2,545 cf, Depth= 1.50"
 Routed to Pond CI-C1 : CI - C1

Runoff by Rational method, Rise/Fall=1.0/1.0 xTc, Time Span= 0.00-3.00 hrs, dt= 0.01 hrs
 AR - Little Rock 100-yr Duration=20 min, Inten=5.78 in/hr

Area (sf)	C	Description
6,135	0.40	Sod Yard
14,202	0.95	Paving, Sidewalks
20,337	0.78	Weighted Average
6,135		30.17% Pervious Area
14,202		69.83% Impervious Area

Tc (min)	Length (feet)	Slope (ft/ft)	Velocity (ft/sec)	Capacity (cfs)	Description
4.8	32	0.0660	0.11		Sheet Flow, Sheet Flow Grass: Bermuda n= 0.410 P2= 4.19"
0.4	102	0.0470	4.40		Shallow Concentrated Flow, Concentrated Flow Paved Kv= 20.3 fps
5.2	134	Total			

Subcatchment C1: Drainage Basin C1

Hydrograph

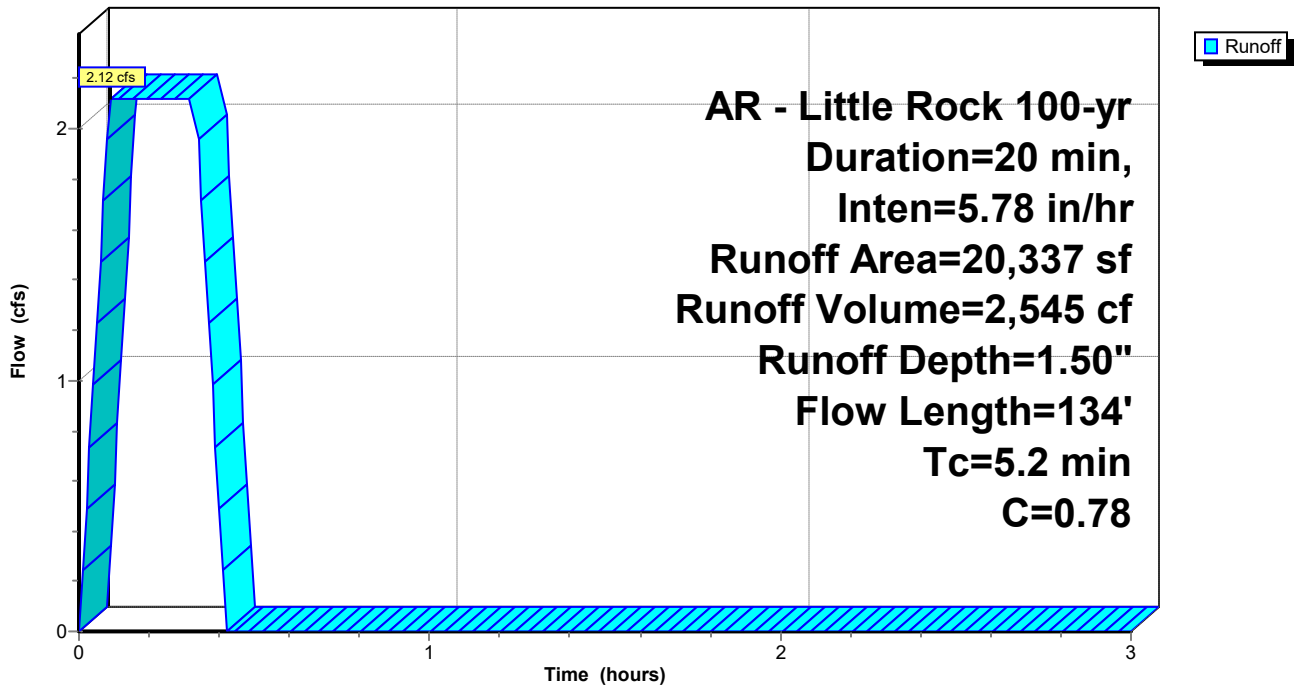

Goddard

Prepared by Phillip Lewis Engineering

HydroCAD® 10.20-5c s/n 12520 © 2023 HydroCAD Software Solutions LLC

AR - Little Rock 100-yr Duration=20 min, Inten=5.78 in/hr

Printed 3/25/2026

Summary for Subcatchment C10: Drainage Basin C10

Runoff = 0.60 cfs @ 0.09 hrs, Volume= 721 cf, Depth= 1.60"
 Routed to Pond CI-E1 : CI - E1

Runoff by Rational method, Rise/Fall=1.0/1.0 xTc, Time Span= 0.00-3.00 hrs, dt= 0.01 hrs
 AR - Little Rock 100-yr Duration=20 min, Inten=5.78 in/hr

Area (sf)	C	Description
1,225	0.40	Sod Yard
4,183	0.95	Paving, Sidewalks
5,408	0.83	Weighted Average
1,225		22.65% Pervious Area
4,183		77.35% Impervious Area

Tc (min)	Length (feet)	Slope (ft/ft)	Velocity (ft/sec)	Capacity (cfs)	Description
0.3	18	0.0200	1.12		Sheet Flow, Sheet Flow Smooth surfaces n= 0.011 P2= 4.19"
0.2	29	0.0210	2.94		Shallow Concentrated Flow, Concentrated Flow Paved Kv= 20.3 fps
0.1	23	0.0320	3.63		Shallow Concentrated Flow, Concentrated Flow Paved Kv= 20.3 fps
0.2	36	0.0320	3.63		Shallow Concentrated Flow, Concentrated Flow Paved Kv= 20.3 fps
0.2	48	0.0330	3.69		Shallow Concentrated Flow, Concentrated Flow Paved Kv= 20.3 fps
0.1	13	0.0350	3.80		Shallow Concentrated Flow, Concentrated Flow Paved Kv= 20.3 fps
3.9	415		1.77		Direct Entry, Concentrated Flow (Min)
5.0	582	Total			

Subcatchment C10: Drainage Basin C10

Hydrograph

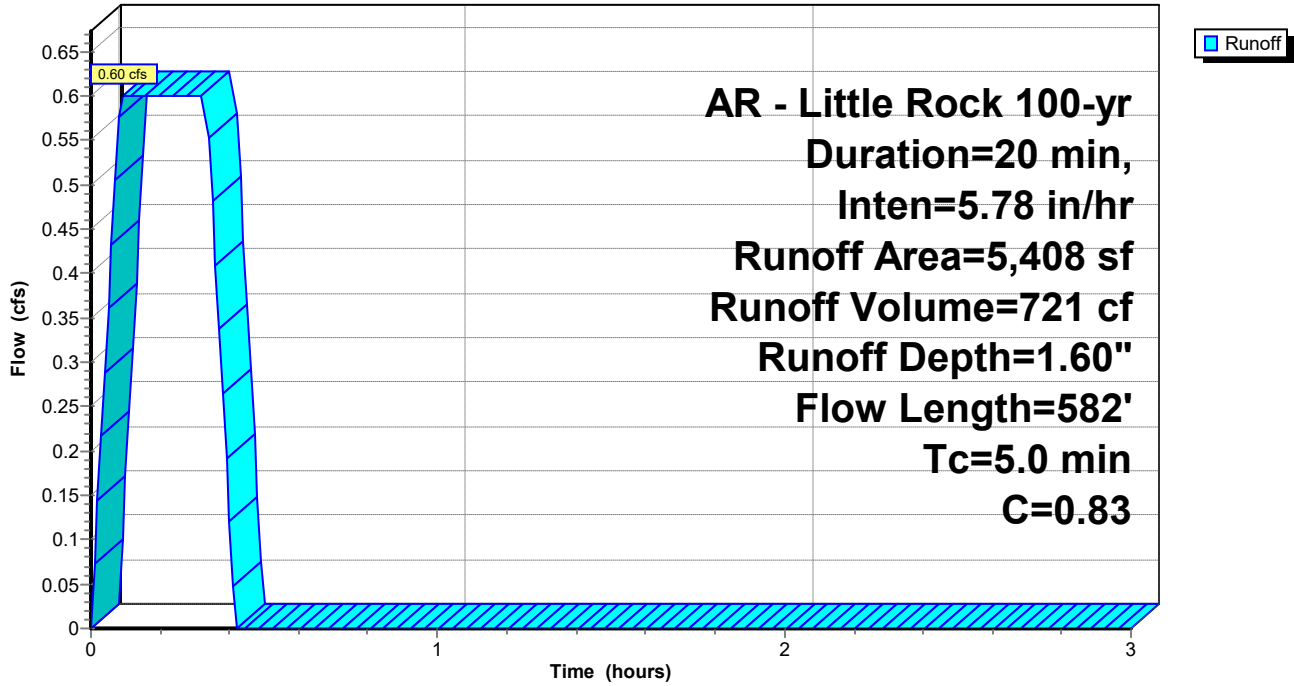

Goddard

Prepared by Phillip Lewis Engineering

HydroCAD® 10.20-5c s/n 12520 © 2023 HydroCAD Software Solutions LLC

AR - Little Rock 100-yr Duration=20 min, Inten=5.78 in/hr

Printed 3/25/2026

Summary for Subcatchment C11: Drainage Basin C11

Runoff = 0.57 cfs @ 0.09 hrs, Volume= 685 cf, Depth= 1.33"
 Routed to Pond CI-E2 : CI - E2

Runoff by Rational method, Rise/Fall=1.0/1.0 xTc, Time Span= 0.00-3.00 hrs, dt= 0.01 hrs
 AR - Little Rock 100-yr Duration=20 min, Inten=5.78 in/hr

Area (sf)	C	Description
2,876	0.40	Sod Yard
3,307	0.95	Paving, Sidewalks
6,183	0.69	Weighted Average
2,876		46.51% Pervious Area
3,307		53.49% Impervious Area

Tc (min)	Length (feet)	Slope (ft/ft)	Velocity (ft/sec)	Capacity (cfs)	Description
0.3	25	0.0200	1.19		Sheet Flow, Sheet Flow Smooth surfaces n= 0.011 P2= 4.19"
0.1	33	0.0620	5.05		Shallow Concentrated Flow, Concentrated Flow Paved Kv= 20.3 fps
0.1	29	0.0540	4.72		Shallow Concentrated Flow, Concentrated Flow Paved Kv= 20.3 fps
0.2	47	0.0410	4.11		Shallow Concentrated Flow, Concentrated Flow Paved Kv= 20.3 fps
0.2	47	0.0390	4.01		Shallow Concentrated Flow, Concentrated Flow Paved Kv= 20.3 fps
0.1	37	0.0420	4.16		Shallow Concentrated Flow, Concentrated Flow Paved Kv= 20.3 fps
4.0	415		1.73		Direct Entry, Concentrated Flow (Min)
5.0	633	Total			

Subcatchment C11: Drainage Basin C11

Hydrograph

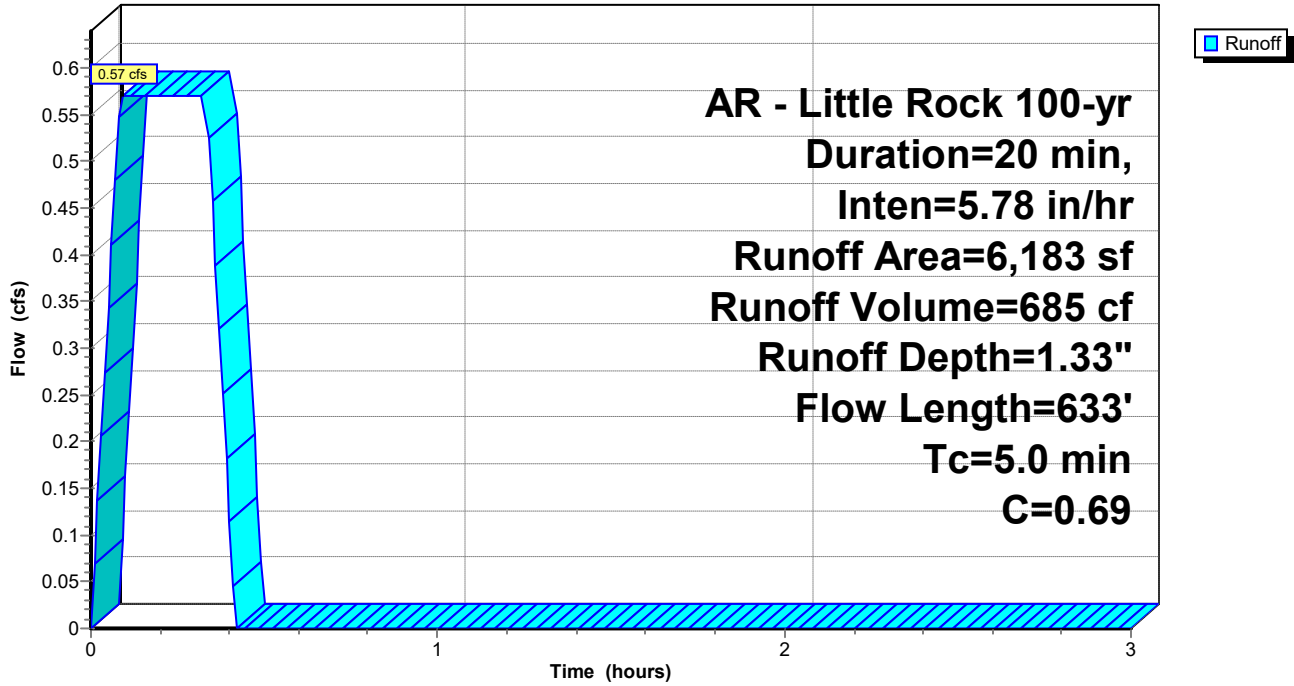

Goddard

Prepared by Phillip Lewis Engineering

HydroCAD® 10.20-5c s/n 12520 © 2023 HydroCAD Software Solutions LLC

AR - Little Rock 100-yr Duration=20 min, Inten=5.78 in/hr

Printed 3/25/2026

Summary for Subcatchment C12: Drainage Basin C12

Runoff = 2.75 cfs @ 0.09 hrs, Volume= 3,295 cf, Depth= 1.54"
 Routed to Pond CI-C7 : CI - C7

Runoff by Rational method, Rise/Fall=1.0/1.0 xTc, Time Span= 0.00-3.00 hrs, dt= 0.01 hrs
 AR - Little Rock 100-yr Duration=20 min, Inten=5.78 in/hr

Area (sf)	C	Description
7,218	0.40	Sod Yard
18,440	0.95	Paving, Sidewalks
25,658	0.80	Weighted Average
7,218		28.13% Pervious Area
18,440		71.87% Impervious Area

Tc (min)	Length (feet)	Slope (ft/ft)	Velocity (ft/sec)	Capacity (cfs)	Description
0.3	24	0.0360	1.50		Sheet Flow, Sheet Flow Smooth surfaces n= 0.011 P2= 4.19"
0.1	5	0.0190	0.85		Sheet Flow, Sheet Flow Smooth surfaces n= 0.011 P2= 4.19"
0.2	21	0.0100	2.03		Shallow Concentrated Flow, Concentrated Flow Paved Kv= 20.3 fps
0.9	49	0.0020	0.91		Shallow Concentrated Flow, Concentrated Flow Paved Kv= 20.3 fps
0.4	96	0.0330	3.69		Shallow Concentrated Flow, Concentrated Flow Paved Kv= 20.3 fps
0.3	94	0.0570	4.85		Shallow Concentrated Flow, Concentrated Flow Paved Kv= 20.3 fps
0.1	28	0.0560	4.80		Shallow Concentrated Flow, Concentrated Flow Paved Kv= 20.3 fps
0.1	25	0.0450	4.31		Shallow Concentrated Flow, Concentrated Flow Paved Kv= 20.3 fps
0.1	31	0.0410	4.11		Shallow Concentrated Flow, Concentrated Flow Paved Kv= 20.3 fps
0.1	39	0.0490	4.49		Shallow Concentrated Flow, Concentrated Flow Paved Kv= 20.3 fps
0.1	36	0.0460	4.35		Shallow Concentrated Flow, Concentrated Flow Paved Kv= 20.3 fps
0.0	11	0.0470	4.40		Shallow Concentrated Flow, Concentrated Flow Paved Kv= 20.3 fps
0.0	6	0.0440	4.26		Shallow Concentrated Flow, Concentrated Flow Paved Kv= 20.3 fps
2.3	415		3.01		Direct Entry, Concentrated Flow (Min)
5.0	880	Total			

Subcatchment C12: Drainage Basin C12

Hydrograph

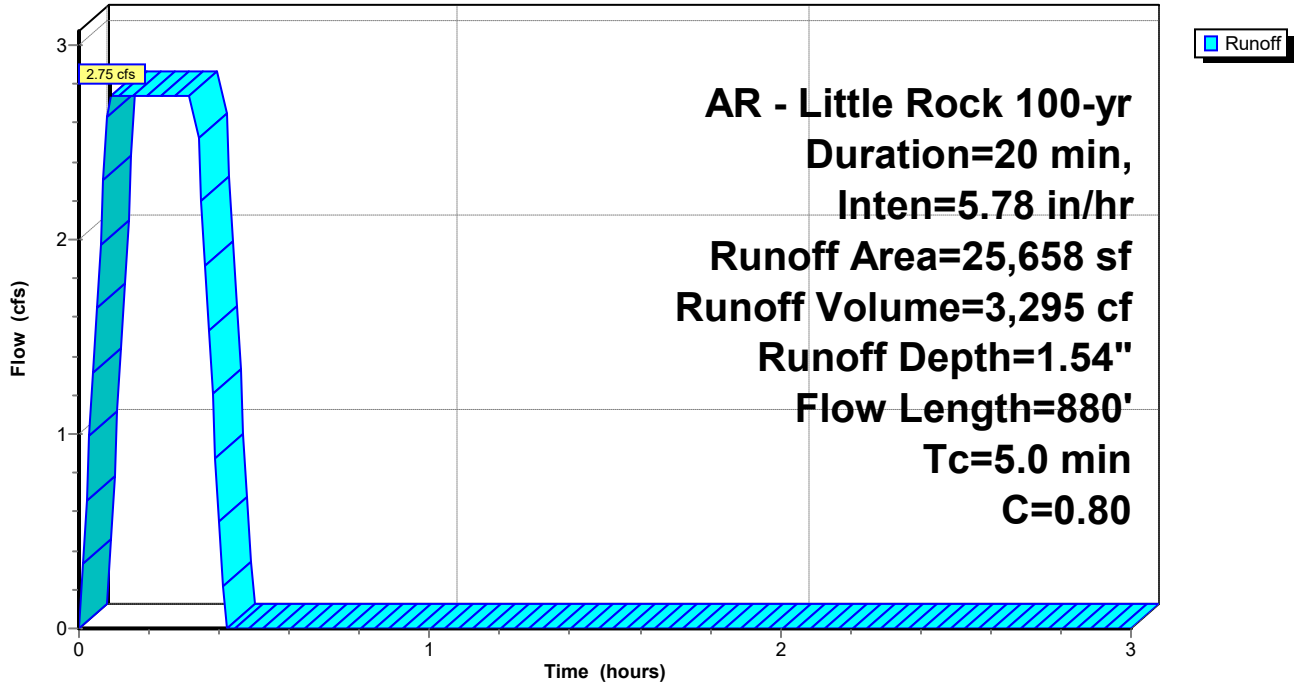

Goddard

Prepared by Phillip Lewis Engineering

HydroCAD® 10.20-5c s/n 12520 © 2023 HydroCAD Software Solutions LLC

AR - Little Rock 100-yr Duration=20 min, Inten=5.78 in/hr

Printed 3/25/2026

Summary for Subcatchment C13: Drainage Basin C13

Runoff = 0.89 cfs @ 0.09 hrs, Volume= 1,071 cf, Depth= 1.62"
 Routed to Pond CI-A4 : CI - A4

Runoff by Rational method, Rise/Fall=1.0/1.0 xTc, Time Span= 0.00-3.00 hrs, dt= 0.01 hrs
 AR - Little Rock 100-yr Duration=20 min, Inten=5.78 in/hr

Area (sf)	C	Description
1,558	0.40	Sod Yard
6,388	0.95	Paving, Sidewalks
7,946	0.84	Weighted Average
1,558		19.61% Pervious Area
6,388		80.39% Impervious Area

Tc (min)	Length (feet)	Slope (ft/ft)	Velocity (ft/sec)	Capacity (cfs)	Description
0.3	19	0.0200	1.13		Sheet Flow, Sheet Flow Smooth surfaces n= 0.011 P2= 4.19"
0.3	75	0.0340	3.74		Shallow Concentrated Flow, Concentrated Flow Paved Kv= 20.3 fps
0.2	52	0.0410	4.11		Shallow Concentrated Flow, Concentrated Flow Paved Kv= 20.3 fps
0.1	29	0.0470	4.40		Shallow Concentrated Flow, Concentrated Flow Paved Kv= 20.3 fps
0.1	42	0.0730	5.48		Shallow Concentrated Flow, Concentrated Flow Paved Kv= 20.3 fps
0.2	74	0.0750	5.56		Shallow Concentrated Flow, Concentrated Flow Paved Kv= 20.3 fps
0.1	26	0.0710	5.41		Shallow Concentrated Flow, Concentrated Flow Paved Kv= 20.3 fps
0.1	32	0.0570	4.85		Shallow Concentrated Flow, Concentrated Flow Paved Kv= 20.3 fps
0.0	13	0.0470	4.40		Shallow Concentrated Flow, Concentrated Flow Paved Kv= 20.3 fps
3.6	415		1.92		Direct Entry, Overland Concentrated Flow (Min)
5.0	777	Total			

Subcatchment C13: Drainage Basin C13

Hydrograph

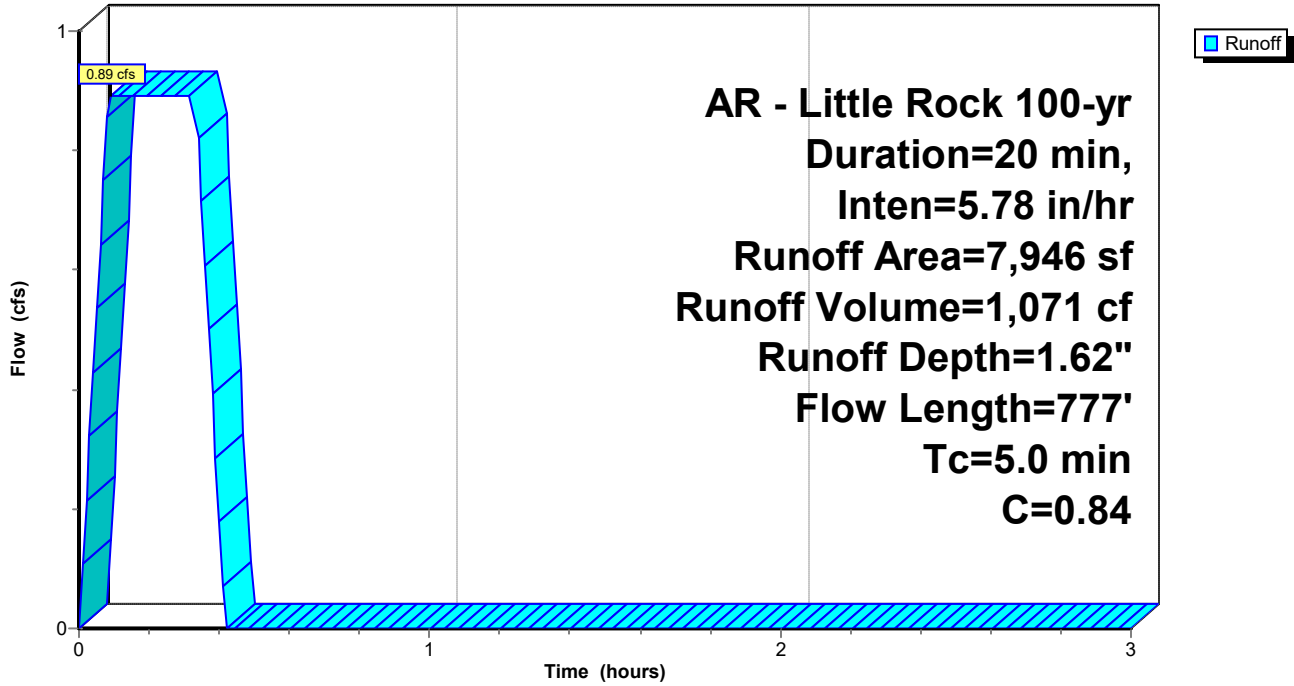

Goddard

Prepared by Phillip Lewis Engineering

HydroCAD® 10.20-5c s/n 12520 © 2023 HydroCAD Software Solutions LLC

AR - Little Rock 100-yr Duration=20 min, Inten=5.78 in/hr

Printed 3/25/2026

Summary for Subcatchment C14: Drainage Basin C14

Runoff = 2.36 cfs @ 0.27 hrs, Volume= 2,829 cf, Depth= 1.54"
 Routed to Pond CI-A5 : CI - A5

Runoff by Rational method, Rise/Fall=1.0/1.0 xTc, Time Span= 0.00-3.00 hrs, dt= 0.01 hrs
 AR - Little Rock 100-yr Duration=20 min, Inten=5.78 in/hr

Area (sf)	C	Description
6,127	0.40	Sod Yard
15,898	0.95	Paving, Sidewalks
22,025	0.80	Weighted Average
6,127		27.82% Pervious Area
15,898		72.18% Impervious Area

Tc (min)	Length (feet)	Slope (ft/ft)	Velocity (ft/sec)	Capacity (cfs)	Description
1.5	5	0.0310	0.06		Sheet Flow, Sheet Flow
					Grass: Bermuda n= 0.410 P2= 4.19"
9.2	45	0.0250	0.08		Sheet Flow, Sheet Flow
					Grass: Bermuda n= 0.410 P2= 4.19"
3.8	41	0.1940	0.18		Sheet Flow, Sheet Flow
					Grass: Bermuda n= 0.410 P2= 4.19"
0.1	6	0.0100	0.68		Sheet Flow, Sheet Flow
					Smooth surfaces n= 0.011 P2= 4.19"
0.1	51	0.0870	5.99		Shallow Concentrated Flow, Concentrated Flow
					Paved Kv= 20.3 fps
0.2	52	0.0310	3.57		Shallow Concentrated Flow, Concentrated Flow
					Paved Kv= 20.3 fps
0.1	18	0.0270	3.34		Shallow Concentrated Flow, Concentrated Flow
					Paved Kv= 20.3 fps
0.1	20	0.0400	4.06		Shallow Concentrated Flow, Concentrated Flow
					Paved Kv= 20.3 fps
0.1	34	0.0410	4.11		Shallow Concentrated Flow, Concentrated Flow
					Paved Kv= 20.3 fps
0.2	46	0.0470	4.40		Shallow Concentrated Flow, Concentrated Flow
					Paved Kv= 20.3 fps
0.1	36	0.0580	4.89		Shallow Concentrated Flow, Concentrated Flow
					Paved Kv= 20.3 fps
0.2	58	0.0690	5.33		Shallow Concentrated Flow, Concentrated Flow
					Paved Kv= 20.3 fps
0.1	49	0.0840	5.88		Shallow Concentrated Flow, Concentrated Flow
					Paved Kv= 20.3 fps
0.1	31	0.0690	5.33		Shallow Concentrated Flow, Concentrated Flow
					Paved Kv= 20.3 fps
15.9	492	Total			

Subcatchment C14: Drainage Basin C14

Hydrograph

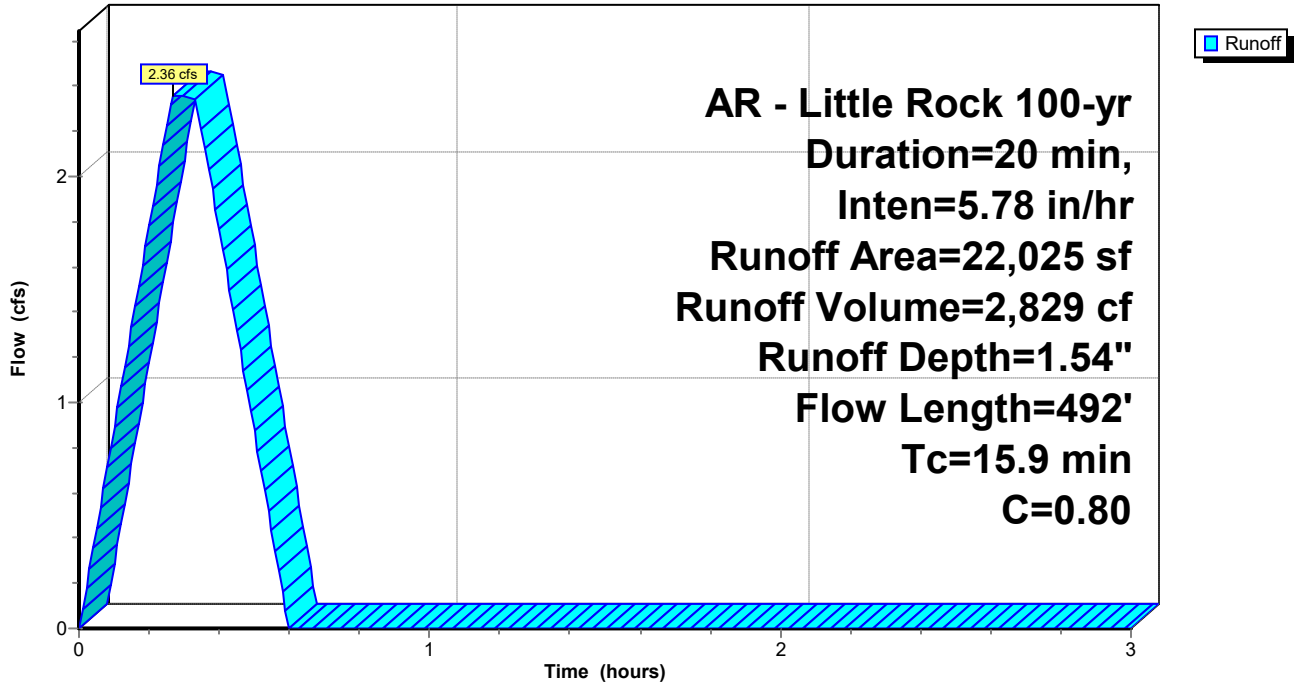

Summary for Subcatchment C15: Drainage Basin C15

Runoff = 1.71 cfs @ 0.09 hrs, Volume= 2,051 cf, Depth= 1.83"

Routed to Pond DP : Existing North Detention Pond

Runoff by Rational method, Rise/Fall=1.0/1.0 xTc, Time Span= 0.00-3.00 hrs, dt= 0.01 hrs
 AR - Little Rock 100-yr Duration=20 min, Inten=5.78 in/hr

Area (sf)	C	Description
0	0.40	Sod Yard
13,450	0.95	Paving, Sidewalks
13,450	0.95	Weighted Average
13,450		100.00% Impervious Area

Tc (min)	Length (feet)	Slope (ft/ft)	Velocity (ft/sec)	Capacity (cfs)	Description
5.0	415		1.38		Direct Entry, Overland Concentrated Flow (Min)

Subcatchment C15: Drainage Basin C15

Hydrograph

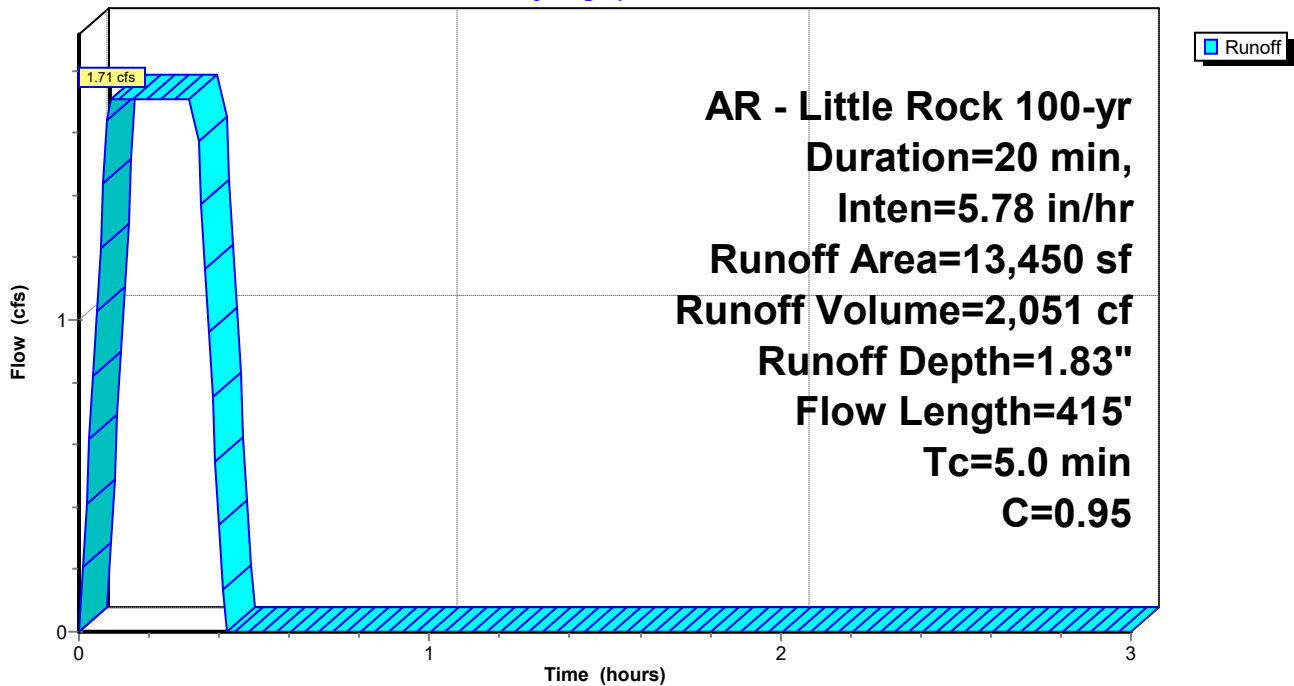

Summary for Subcatchment C16: Drainage Basin C16

Runoff = 1.65 cfs @ 0.09 hrs, Volume= 1,985 cf, Depth= 1.08"

Routed to Pond DP : Existing North Detention Pond

Runoff by Rational method, Rise/Fall=1.0/1.0 xTc, Time Span= 0.00-3.00 hrs, dt= 0.01 hrs
 AR - Little Rock 100-yr Duration=20 min, Inten=5.78 in/hr

Area (sf)	C	Description
15,465	0.40	Sod Yard
6,612	0.95	Paving, Sidewalks
22,077	0.56	Weighted Average
15,465		70.05% Pervious Area
6,612		29.95% Impervious Area

Tc (min)	Length (feet)	Slope (ft/ft)	Velocity (ft/sec)	Capacity (cfs)	Description
0.4	26	0.0190	1.18		Sheet Flow, Sheet Flow Smooth surfaces n= 0.011 P2= 4.19"
0.1	5	0.0100	0.66		Sheet Flow, Sheet Flow Smooth surfaces n= 0.011 P2= 4.19"
0.4	51	0.0500	1.98		Sheet Flow, Sheet Flow Smooth surfaces n= 0.011 P2= 4.19"
0.1	12	0.1540	2.33		Sheet Flow, Sheet Flow Smooth surfaces n= 0.011 P2= 4.19"
0.1	50	0.1330	7.40		Shallow Concentrated Flow, Concentrated Flow Paved Kv= 20.3 fps
0.1	50	0.1170	6.94		Shallow Concentrated Flow, Concentrated Flow Paved Kv= 20.3 fps
0.2	46	0.0430	4.21		Shallow Concentrated Flow, Concentrated Flow Paved Kv= 20.3 fps
0.3	59	0.0370	3.90		Shallow Concentrated Flow, Concentrated Flow Paved Kv= 20.3 fps
3.3	415		2.10		Direct Entry, Overland Concentrated Flow (Min)
5.0	714	Total			

Subcatchment C16: Drainage Basin C16

Hydrograph

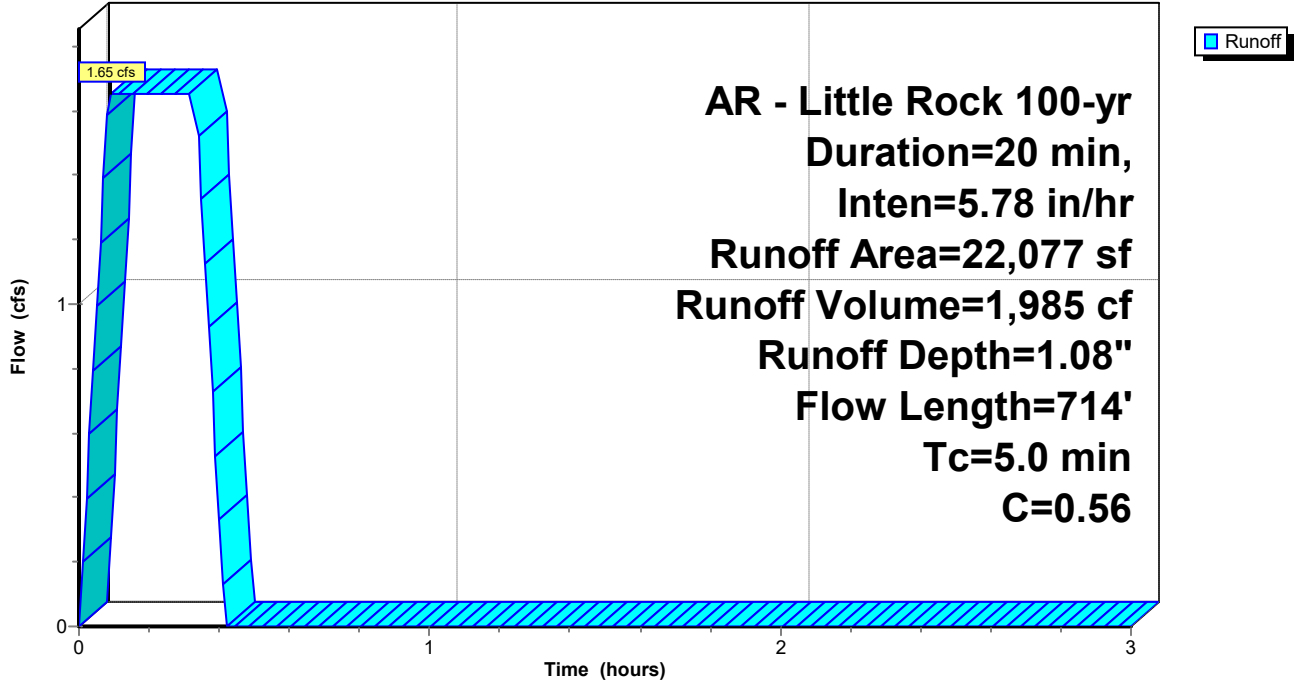

Summary for Subcatchment C17: Drainage Basin C17

Runoff = 3.04 cfs @ 0.16 hrs, Volume= 3,645 cf, Depth= 0.77"

Routed to Pond DP : Existing North Detention Pond

Runoff by Rational method, Rise/Fall=1.0/1.0 xTc, Time Span= 0.00-3.00 hrs, dt= 0.01 hrs

AR - Little Rock 100-yr Duration=20 min, Inten=5.78 in/hr

Area (sf)	C	Description
56,749	0.40	Sod Yard
0	0.95	Paving, Sidewalks
56,749	0.40	Weighted Average
56,749		100.00% Pervious Area

Tc (min)	Length (feet)	Slope (ft/ft)	Velocity (ft/sec)	Capacity (cfs)	Description
4.8	43	0.0410	0.15		Sheet Flow, Sheet Flow Grass: Dense n= 0.240 P2= 4.19"
3.9	43	0.0690	0.19		Sheet Flow, Sheet Flow Grass: Dense n= 0.240 P2= 4.19"
0.1	41	0.0980	4.70		Shallow Concentrated Flow, Concentrated Flow Grassed Waterway Kv= 15.0 fps
0.3	61	0.0730	4.05		Shallow Concentrated Flow, Concentrated Flow Grassed Waterway Kv= 15.0 fps
0.2	46	0.0570	3.58		Shallow Concentrated Flow, Concentrated Flow Grassed Waterway Kv= 15.0 fps
0.3	64	0.0450	3.18		Shallow Concentrated Flow, Concentrated Flow Grassed Waterway Kv= 15.0 fps
9.6	298	Total			

Subcatchment C17: Drainage Basin C17

Hydrograph

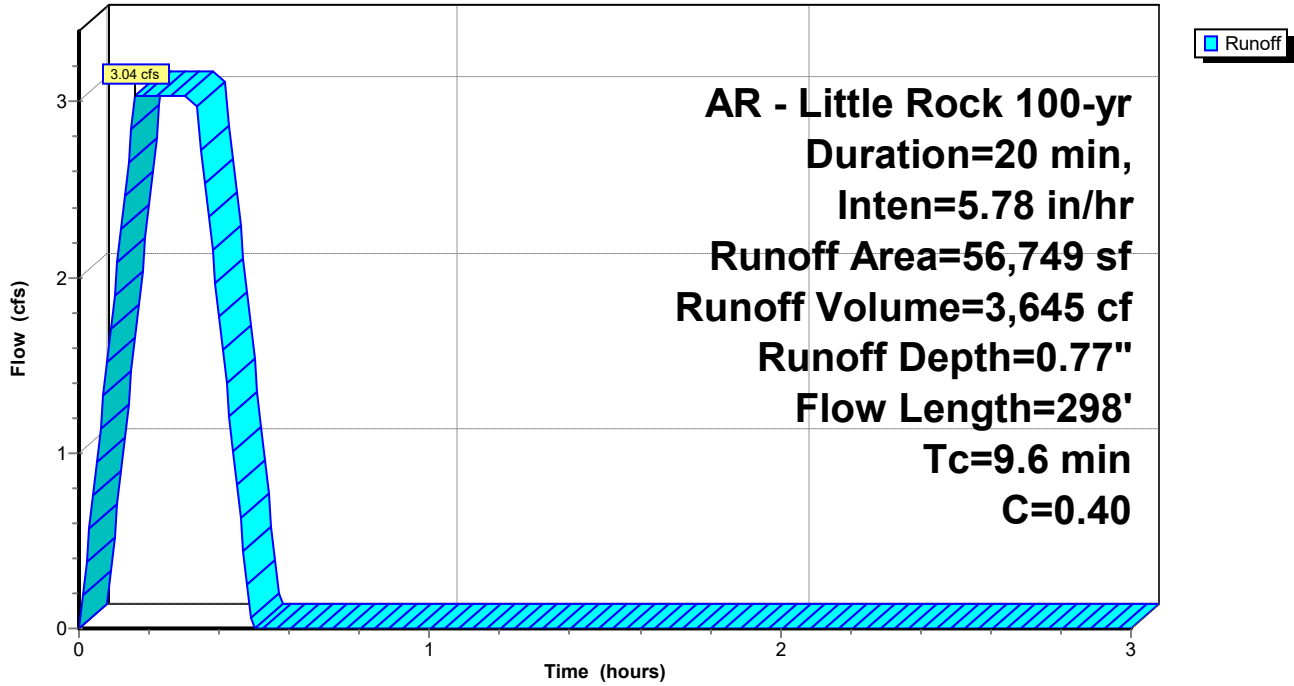

Summary for Subcatchment C18: Drainage Basin C18

Runoff = 1.95 cfs @ 0.09 hrs, Volume= 2,341 cf, Depth= 1.23"
 Routed to Link FINAL : APPROX DISCHARGE

Runoff by Rational method, Rise/Fall=1.0/1.0 xTc, Time Span= 0.00-3.00 hrs, dt= 0.01 hrs
 AR - Little Rock 100-yr Duration=20 min, Inten=5.78 in/hr

Area (sf)	C	Description
12,812	0.40	Sod Yard
9,973	0.95	Paving, Sidewalks
22,785	0.64	Weighted Average
12,812		56.23% Pervious Area
9,973		43.77% Impervious Area

Tc (min)	Length (feet)	Slope (ft/ft)	Velocity (ft/sec)	Capacity (cfs)	Description
0.6	5	0.2980	0.14		Sheet Flow, Sheet Flow Grass: Bermuda n= 0.410 P2= 4.19"
0.2	12	0.0130	0.87		Sheet Flow, Sheet Flow Smooth surfaces n= 0.011 P2= 4.19"
3.3	8	0.0100	0.04		Sheet Flow, Sheet Flow Grass: Bermuda n= 0.410 P2= 4.19"
0.5	80	0.0210	2.94		Shallow Concentrated Flow, Concentrated Flow Paved Kv= 20.3 fps
0.4	415		17.29		Direct Entry, Concentrated Flow (Min)
5.0	520	Total			

Subcatchment C18: Drainage Basin C18

Hydrograph

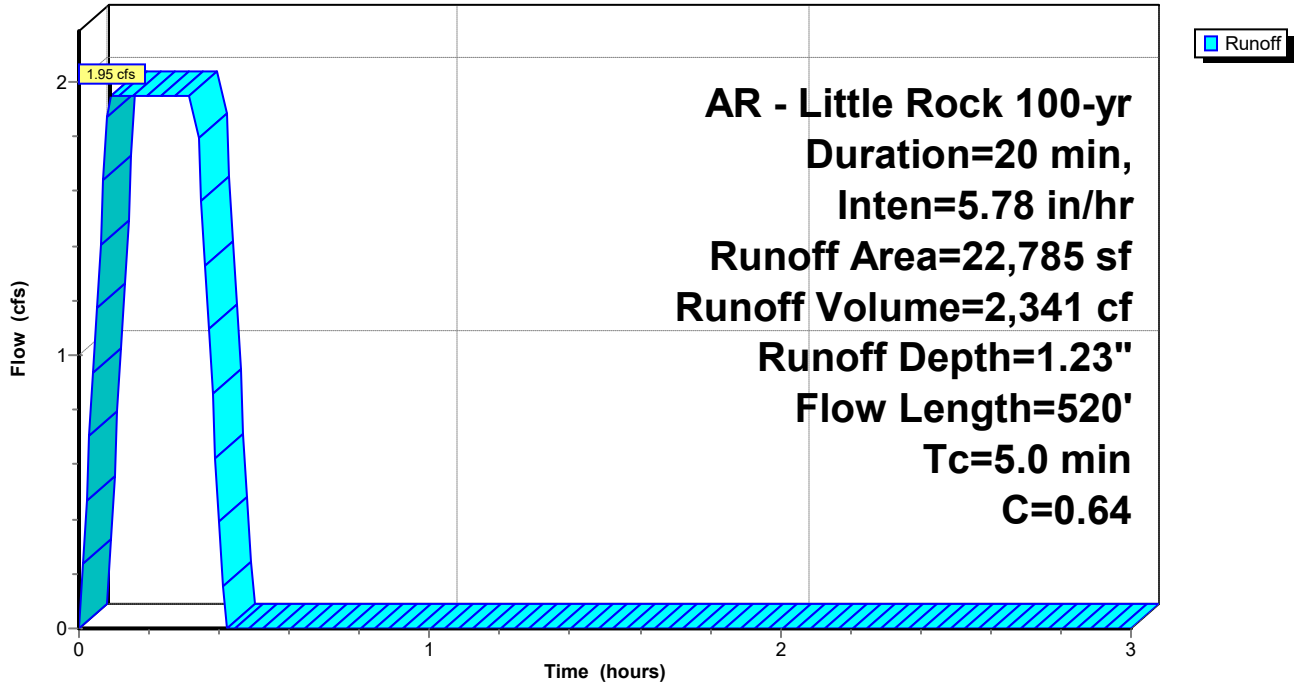

Summary for Subcatchment C19: Drainage Basin C19

Runoff = 0.96 cfs @ 0.12 hrs, Volume= 1,157 cf, Depth= 0.77"
 Routed to Link FINAL : APPROX DISCHARGE

Runoff by Rational method, Rise/Fall=1.0/1.0 xTc, Time Span= 0.00-3.00 hrs, dt= 0.01 hrs
 AR - Little Rock 100-yr Duration=20 min, Inten=5.78 in/hr

Area (sf)	C	Description
18,009	0.40	Sod Yard
0	0.95	Paving, Sidewalks
18,009	0.40	Weighted Average
18,009		100.00% Pervious Area

Tc (min)	Length (feet)	Slope (ft/ft)	Velocity (ft/sec)	Capacity (cfs)	Description
2.7	34	0.1110	0.21		Sheet Flow, Sheet Flow Grass: Dense n= 0.240 P2= 4.19"
3.3	66	0.2450	0.34		Sheet Flow, Sheet Flow Grass: Dense n= 0.240 P2= 4.19"
0.0	9	0.2450	7.42		Shallow Concentrated Flow, Concentrated Flow Grassed Waterway Kv= 15.0 fps
0.5	106	0.0610	3.70		Shallow Concentrated Flow, Concentrated Flow Grassed Waterway Kv= 15.0 fps
0.2	46	0.0800	4.24		Shallow Concentrated Flow, Concentrated Flow Grassed Waterway Kv= 15.0 fps
0.1	41	0.0960	4.65		Shallow Concentrated Flow, Concentrated Flow Grassed Waterway Kv= 15.0 fps
0.3	66	0.0680	3.91		Shallow Concentrated Flow, Concentrated Flow Grassed Waterway Kv= 15.0 fps
0.1	19	0.1070	4.91		Shallow Concentrated Flow, Concentrated Flow Grassed Waterway Kv= 15.0 fps
0.0	6	0.0750	4.11		Shallow Concentrated Flow, Concentrated Flow Grassed Waterway Kv= 15.0 fps
7.2	393	Total			

Subcatchment C19: Drainage Basin C19

Hydrograph

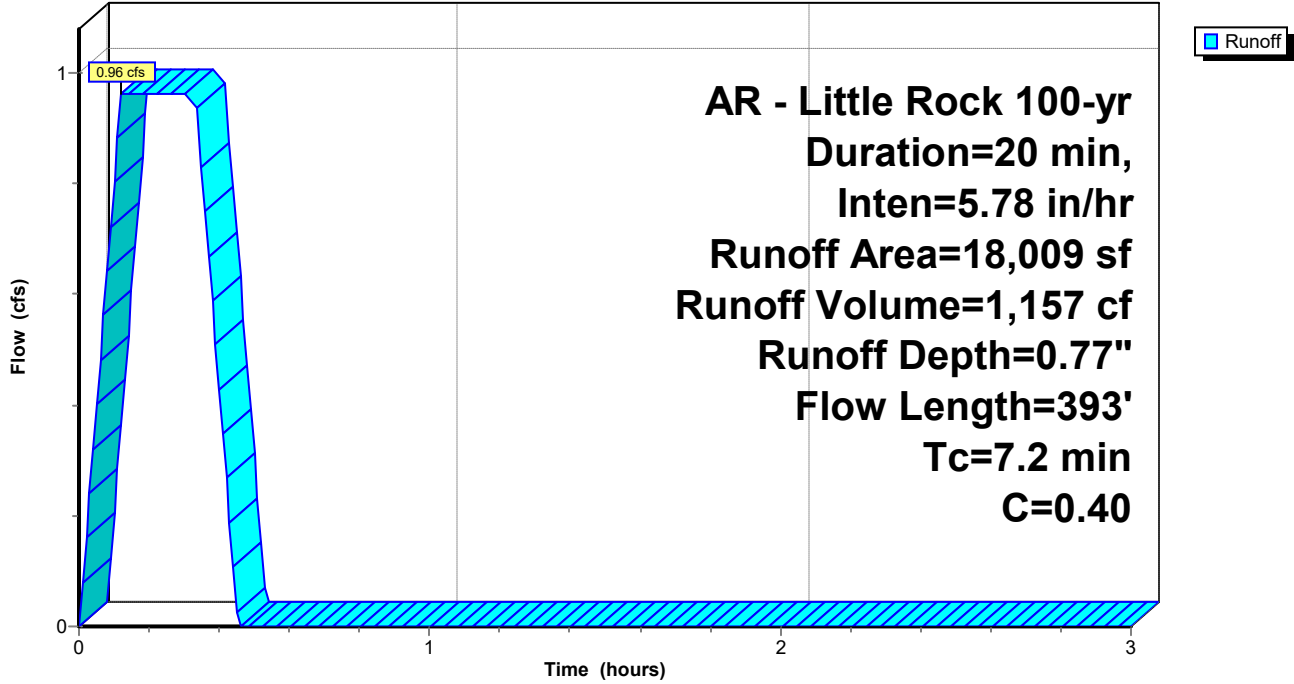

Goddard

Prepared by Phillip Lewis Engineering

HydroCAD® 10.20-5c s/n 12520 © 2023 HydroCAD Software Solutions LLC

AR - Little Rock 100-yr Duration=20 min, Inten=5.78 in/hr

Printed 3/25/2026

Summary for Subcatchment C2: Drainage Basin C2

Runoff = 3.54 cfs @ 0.09 hrs, Volume= 4,244 cf, Depth= 1.48"
 Routed to Pond CI-C2 : CI - C2

Runoff by Rational method, Rise/Fall=1.0/1.0 xTc, Time Span= 0.00-3.00 hrs, dt= 0.01 hrs
 AR - Little Rock 100-yr Duration=20 min, Inten=5.78 in/hr

Area (sf)	C	Description
11,376	0.40	Sod Yard
22,963	0.95	Roof, Paving, Sidewalks
34,339	0.77	Weighted Average
11,376		33.13% Pervious Area
22,963		66.87% Impervious Area

Tc (min)	Length (feet)	Slope (ft/ft)	Velocity (ft/sec)	Capacity (cfs)	Description
0.3	20	0.0200	1.14		Sheet Flow, Sheet Flow Smooth surfaces n= 0.011 P2= 4.19"
0.4	74	0.0240	3.14		Shallow Concentrated Flow, Concentrated Flow Paved Kv= 20.3 fps
0.1	17	0.0710	5.41		Shallow Concentrated Flow, Concentrated Flow Paved Kv= 20.3 fps
0.1	21	0.0610	5.01		Shallow Concentrated Flow, Concentrated Flow Paved Kv= 20.3 fps
0.6	148	0.0380	3.96		Shallow Concentrated Flow, Concentrated Flow Paved Kv= 20.3 fps
3.5	415		1.98		Direct Entry, Concentrated Flow (Min)
5.0	695	Total			

Subcatchment C2: Drainage Basin C2

Hydrograph

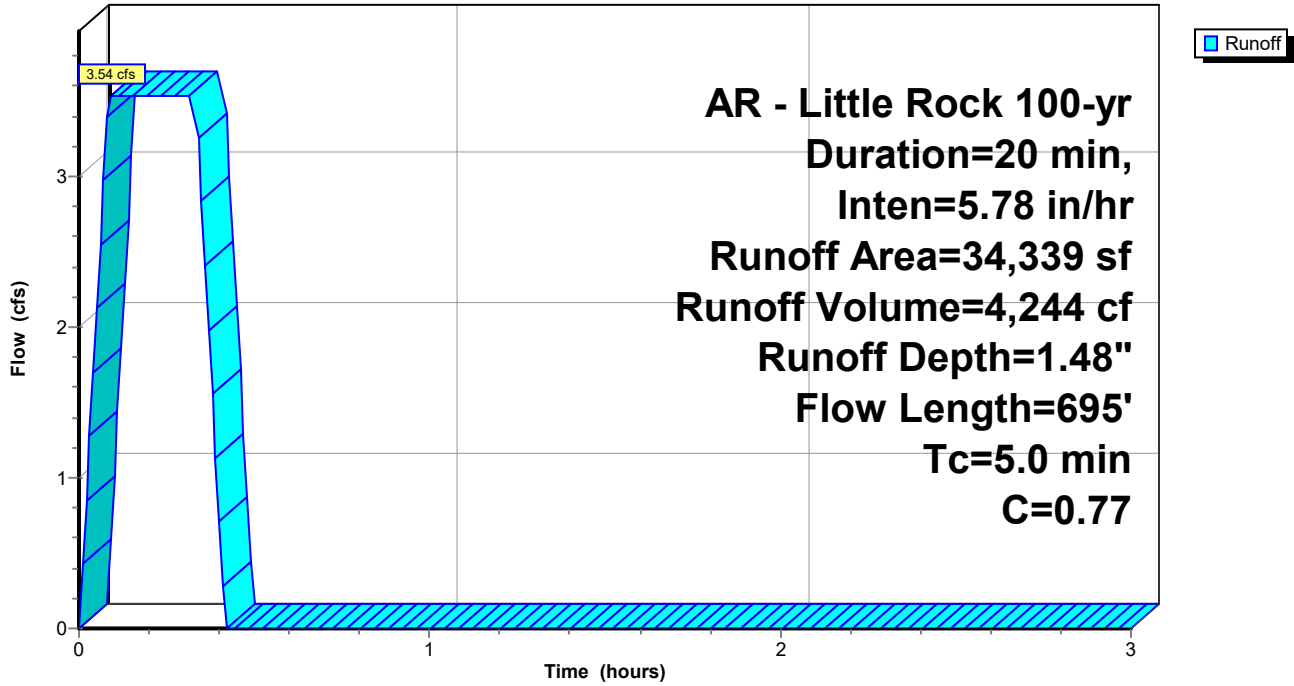

Goddard

Prepared by Phillip Lewis Engineering

HydroCAD® 10.20-5c s/n 12520 © 2023 HydroCAD Software Solutions LLC

AR - Little Rock 100-yr Duration=20 min, Inten=5.78 in/hr

Printed 3/25/2026

Summary for Subcatchment C20: Drainage Basin C20

Runoff = 1.65 cfs @ 0.14 hrs, Volume= 1,978 cf, Depth= 0.77"

Routed to Link FINAL : APPROX DISCHARGE

Runoff by Rational method, Rise/Fall=1.0/1.0 xTc, Time Span= 0.00-3.00 hrs, dt= 0.01 hrs

AR - Little Rock 100-yr Duration=20 min, Inten=5.78 in/hr

Area (sf)	C	Description
30,789	0.40	Sod Yard
0	0.95	Paving, Sidewalks
30,789	0.40	Weighted Average
30,789		100.00% Pervious Area

Tc (min)	Length (feet)	Slope (ft/ft)	Velocity (ft/sec)	Capacity (cfs)	Description
3.0	45	0.1430	0.25		Sheet Flow, Sheet Flow Grass: Dense n= 0.240 P2= 4.19"
4.5	55	0.0780	0.20		Sheet Flow, Sheet Flow Grass: Dense n= 0.240 P2= 4.19"
0.1	37	0.0780	4.19		Shallow Concentrated Flow, Concentrated Flow Grassed Waterway Kv= 15.0 fps
0.3	68	0.0710	4.00		Shallow Concentrated Flow, Concentrated Flow Grassed Waterway Kv= 15.0 fps
7.9	205	Total			

Subcatchment C20: Drainage Basin C20

Hydrograph

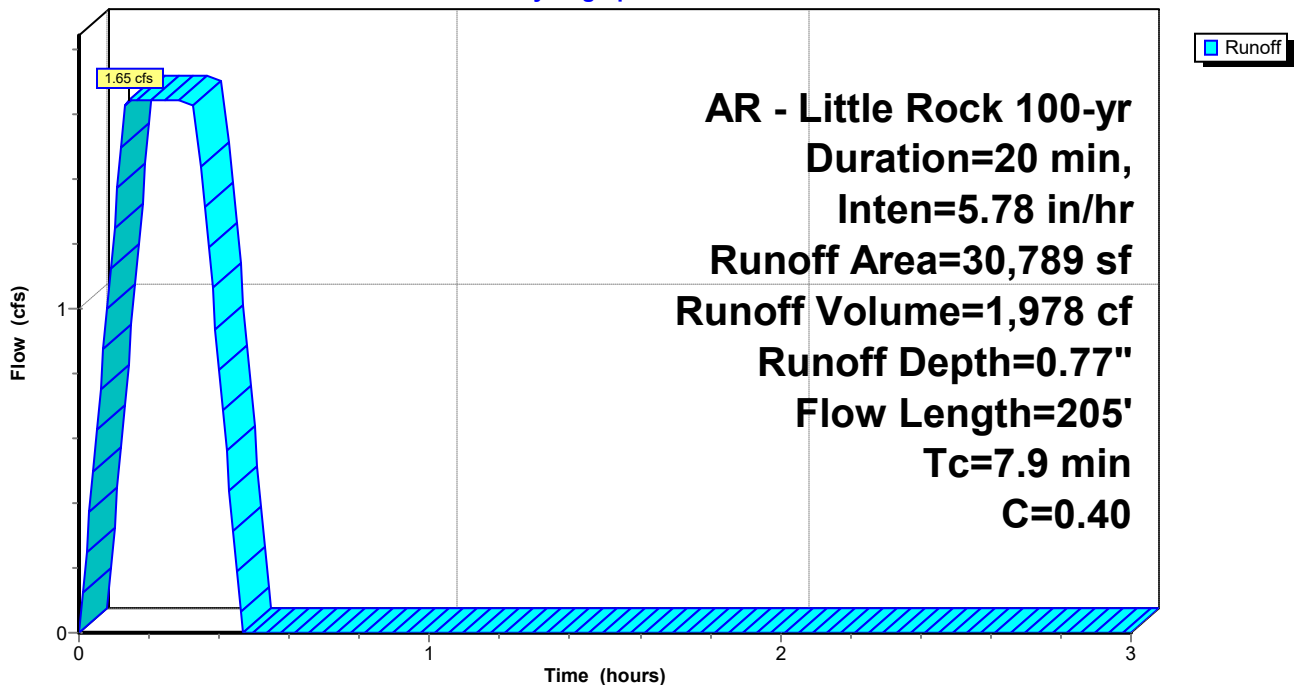

Goddard

Prepared by Phillip Lewis Engineering

HydroCAD® 10.20-5c s/n 12520 © 2023 HydroCAD Software Solutions LLC

AR - Little Rock 100-yr Duration=20 min, Inten=5.78 in/hr

Printed 3/25/2026

Summary for Subcatchment C3: Drainage Basin C3

Runoff = 0.44 cfs @ 0.09 hrs, Volume= 531 cf, Depth= 1.83"
 Routed to Pond CI-C3 : CI - C3

Runoff by Rational method, Rise/Fall=1.0/1.0 xTc, Time Span= 0.00-3.00 hrs, dt= 0.01 hrs
 AR - Little Rock 100-yr Duration=20 min, Inten=5.78 in/hr

Area (sf)	C	Description
0	0.40	Sod Yard
3,480	0.95	Paving, Sidewalks
3,480	0.95	Weighted Average
3,480		100.00% Impervious Area

Tc (min)	Length (feet)	Slope (ft/ft)	Velocity (ft/sec)	Capacity (cfs)	Description
0.3	22	0.0200	1.16		Sheet Flow, Sheet Flow Smooth surfaces n= 0.011 P2= 4.19"
0.0	10	0.0340	3.74		Shallow Concentrated Flow, Concentrated Flow Paved Kv= 20.3 fps
0.1	18	0.0390	4.01		Shallow Concentrated Flow, Concentrated Flow Paved Kv= 20.3 fps
0.6	147	0.0380	3.96		Shallow Concentrated Flow, Concentrated Flow Paved Kv= 20.3 fps
4.0	415		1.73		Direct Entry, Concentrated Flow (Min)
5.0	612	Total			

Subcatchment C3: Drainage Basin C3

Hydrograph

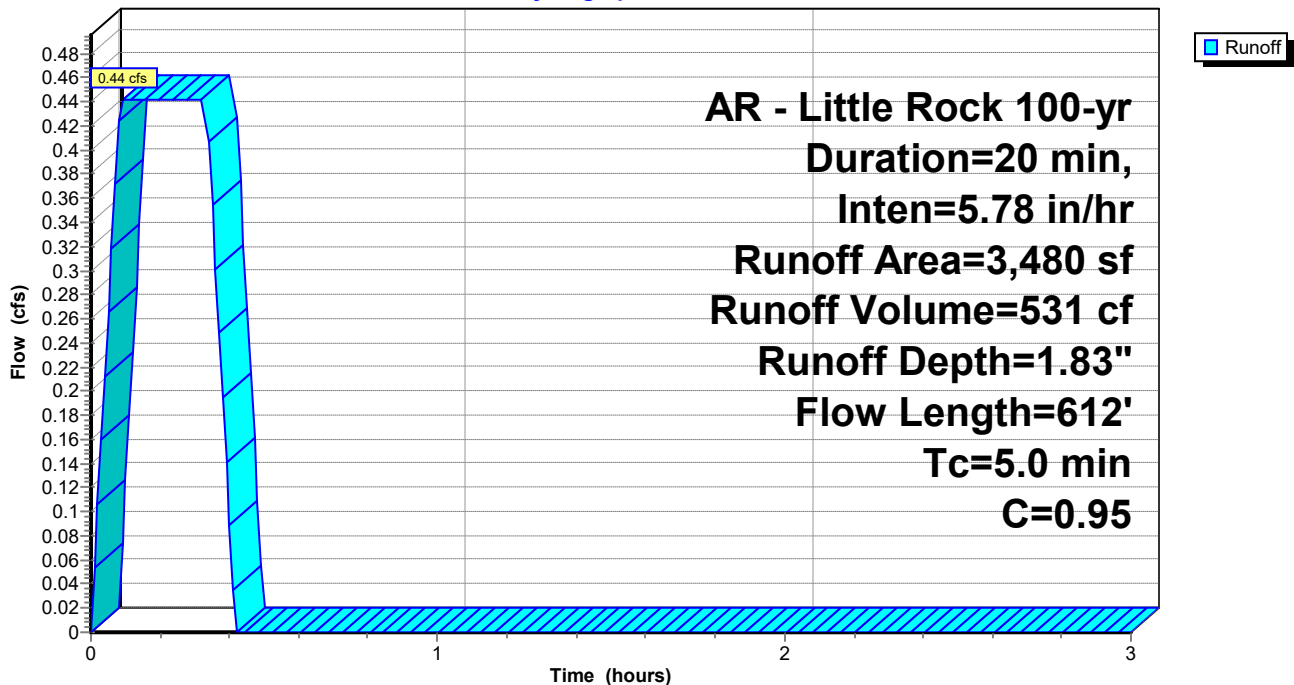

Summary for Subcatchment C4: Drainage Basin C4

Runoff = 0.85 cfs @ 0.09 hrs, Volume= 1,023 cf, Depth= 1.08"
 Routed to Pond CI-C3 : CI - C3

Runoff by Rational method, Rise/Fall=1.0/1.0 xTc, Time Span= 0.00-3.00 hrs, dt= 0.01 hrs
 AR - Little Rock 100-yr Duration=20 min, Inten=5.78 in/hr

Area (sf)	C	Description
8,130	0.40	Sod Yard
3,245	0.95	Paving, Sidewalks
11,375	0.56	Weighted Average
8,130		71.47% Pervious Area
3,245		28.53% Impervious Area

Tc (min)	Length (feet)	Slope (ft/ft)	Velocity (ft/sec)	Capacity (cfs)	Description
5.0	415		1.38		Direct Entry, Concentrated Flow (Min)

Subcatchment C4: Drainage Basin C4

Hydrograph

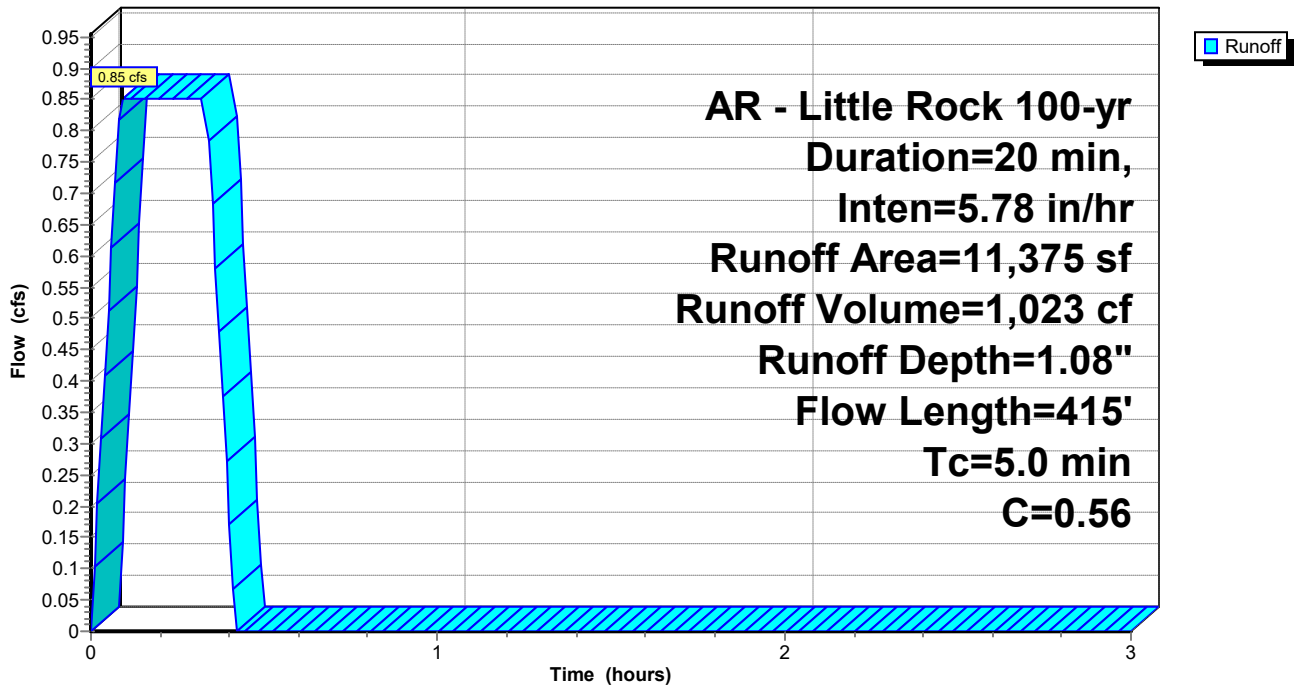

Goddard

Prepared by Phillip Lewis Engineering

HydroCAD® 10.20-5c s/n 12520 © 2023 HydroCAD Software Solutions LLC

AR - Little Rock 100-yr Duration=20 min, Inten=5.78 in/hr

Printed 3/25/2026

Summary for Subcatchment C5: Drainage Basin C5

Runoff = 0.73 cfs @ 0.10 hrs, Volume= 881 cf, Depth= 1.58"
 Routed to Pond CI-C4 : CI - C4

Runoff by Rational method, Rise/Fall=1.0/1.0 xTc, Time Span= 0.00-3.00 hrs, dt= 0.01 hrs
 AR - Little Rock 100-yr Duration=20 min, Inten=5.78 in/hr

Area (sf)	C	Description
1,634	0.40	Sod Yard
5,061	0.95	Paving, Sidewalks
6,695	0.82	Weighted Average
1,634		24.41% Pervious Area
5,061		75.59% Impervious Area

Tc (min)	Length (feet)	Slope (ft/ft)	Velocity (ft/sec)	Capacity (cfs)	Description
0.6	5	0.2990	0.14		Sheet Flow, Sheet Flow Grass: Bermuda n= 0.410 P2= 4.19"
0.2	12	0.0130	0.87		Sheet Flow, Sheet Flow Smooth surfaces n= 0.011 P2= 4.19"
3.9	8	0.0070	0.03		Sheet Flow, Sheet Flow Grass: Bermuda n= 0.410 P2= 4.19"
0.5	58	0.0080	1.82		Shallow Concentrated Flow, Concentrated Flow Paved Kv= 20.3 fps
0.1	14	0.0280	3.40		Shallow Concentrated Flow, Concentrated Flow Paved Kv= 20.3 fps
0.1	23	0.0370	3.90		Shallow Concentrated Flow, Concentrated Flow Paved Kv= 20.3 fps
0.0	13	0.0940	6.22		Shallow Concentrated Flow, Concentrated Flow Paved Kv= 20.3 fps
0.0	13	0.0560	4.80		Shallow Concentrated Flow, Concentrated Flow Paved Kv= 20.3 fps
0.2	30	0.0180	2.72		Shallow Concentrated Flow, Concentrated Flow Paved Kv= 20.3 fps
5.6	176	Total			

Subcatchment C5: Drainage Basin C5

Hydrograph

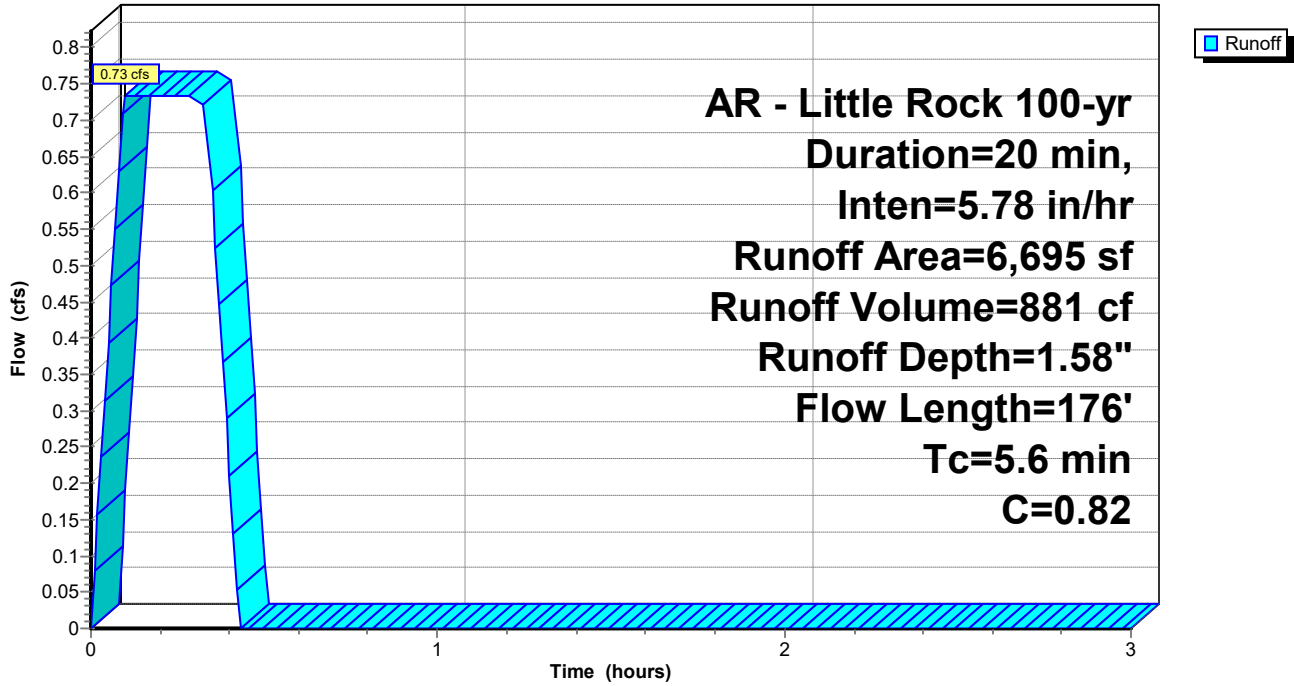

Summary for Subcatchment C6: Drainage Basin C6

Runoff = 0.36 cfs @ 0.09 hrs, Volume= 432 cf, Depth= 1.83"
 Routed to Pond CI-C5 : CI - C5

Runoff by Rational method, Rise/Fall=1.0/1.0 xTc, Time Span= 0.00-3.00 hrs, dt= 0.01 hrs
 AR - Little Rock 100-yr Duration=20 min, Inten=5.78 in/hr

Area (sf)	C	Description
0	0.40	Sod Yard
2,835	0.95	Paving, Sidewalks
2,835	0.95	Weighted Average
2,835		100.00% Impervious Area

Tc (min)	Length (feet)	Slope (ft/ft)	Velocity (ft/sec)	Capacity (cfs)	Description
0.3	22	0.0200	1.16		Sheet Flow, Sheet Flow Smooth surfaces n= 0.011 P2= 4.19"
0.2	19	0.0100	2.03		Shallow Concentrated Flow, Concentrated Flow Paved Kv= 20.3 fps
0.1	17	0.0170	2.65		Shallow Concentrated Flow, Concentrated Flow Paved Kv= 20.3 fps
0.1	26	0.0360	3.85		Shallow Concentrated Flow, Concentrated Flow Paved Kv= 20.3 fps
0.1	28	0.0610	5.01		Shallow Concentrated Flow, Concentrated Flow Paved Kv= 20.3 fps
0.1	27	0.0610	5.01		Shallow Concentrated Flow, Concentrated Flow Paved Kv= 20.3 fps
4.1	415		1.69		Direct Entry, Concentrated Flow (Min)
5.0	554	Total			

Subcatchment C6: Drainage Basin C6

Hydrograph

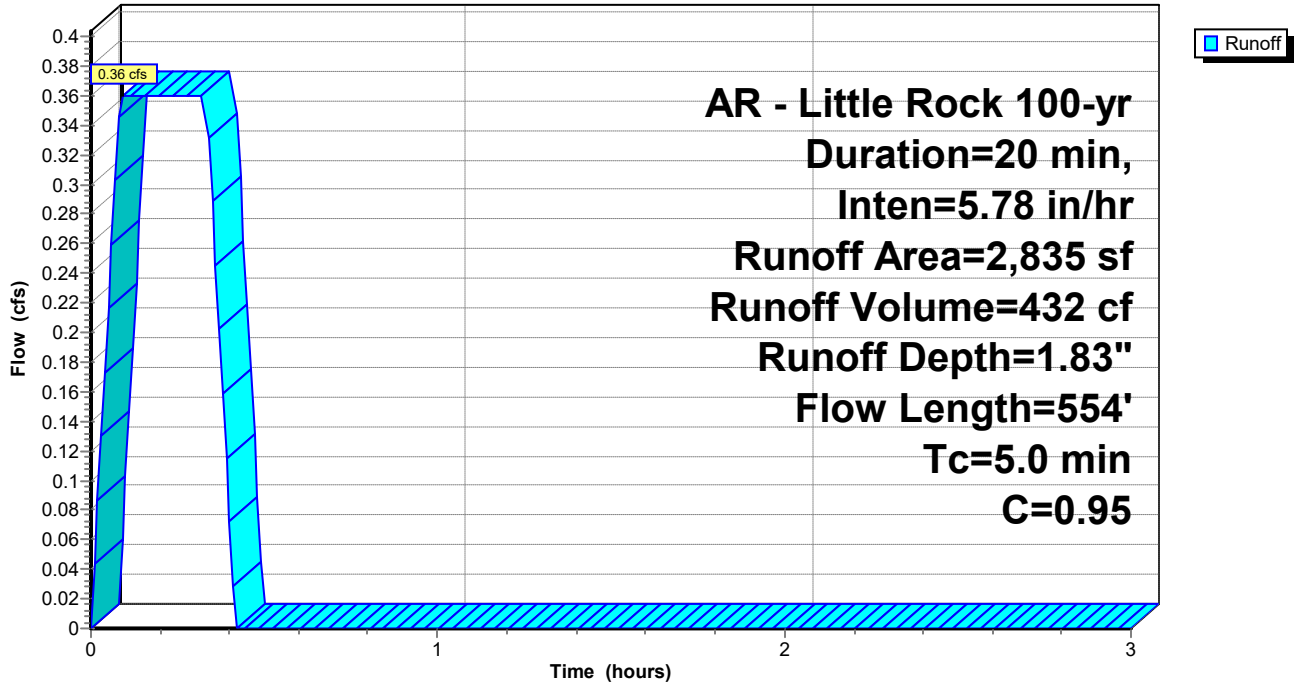

Goddard

Prepared by Phillip Lewis Engineering

HydroCAD® 10.20-5c s/n 12520 © 2023 HydroCAD Software Solutions LLC

AR - Little Rock 100-yr Duration=20 min, Inten=5.78 in/hr

Printed 3/25/2026

Summary for Subcatchment C7: Drainage Basin C7

Runoff = 0.20 cfs @ 0.09 hrs, Volume= 244 cf, Depth= 1.83"
 Routed to Pond CI-D1 : CI - D1

Runoff by Rational method, Rise/Fall=1.0/1.0 xTc, Time Span= 0.00-3.00 hrs, dt= 0.01 hrs
 AR - Little Rock 100-yr Duration=20 min, Inten=5.78 in/hr

Area (sf)	C	Description
0	0.40	Sod Yard
1,597	0.95	Paving, Sidewalks
1,597	0.95	Weighted Average
1,597		100.00% Impervious Area

Tc (min)	Length (feet)	Slope (ft/ft)	Velocity (ft/sec)	Capacity (cfs)	Description
0.3	19	0.0200	1.13		Sheet Flow, Sheet Flow Smooth surfaces n= 0.011 P2= 4.19"
0.1	16	0.0540	4.72		Shallow Concentrated Flow, Concentrated Flow Paved Kv= 20.3 fps
0.3	81	0.0580	4.89		Shallow Concentrated Flow, Concentrated Flow Paved Kv= 20.3 fps
4.3	415		1.61		Direct Entry, Concentrated Flow (Min)
5.0	531	Total			

Subcatchment C7: Drainage Basin C7

Hydrograph

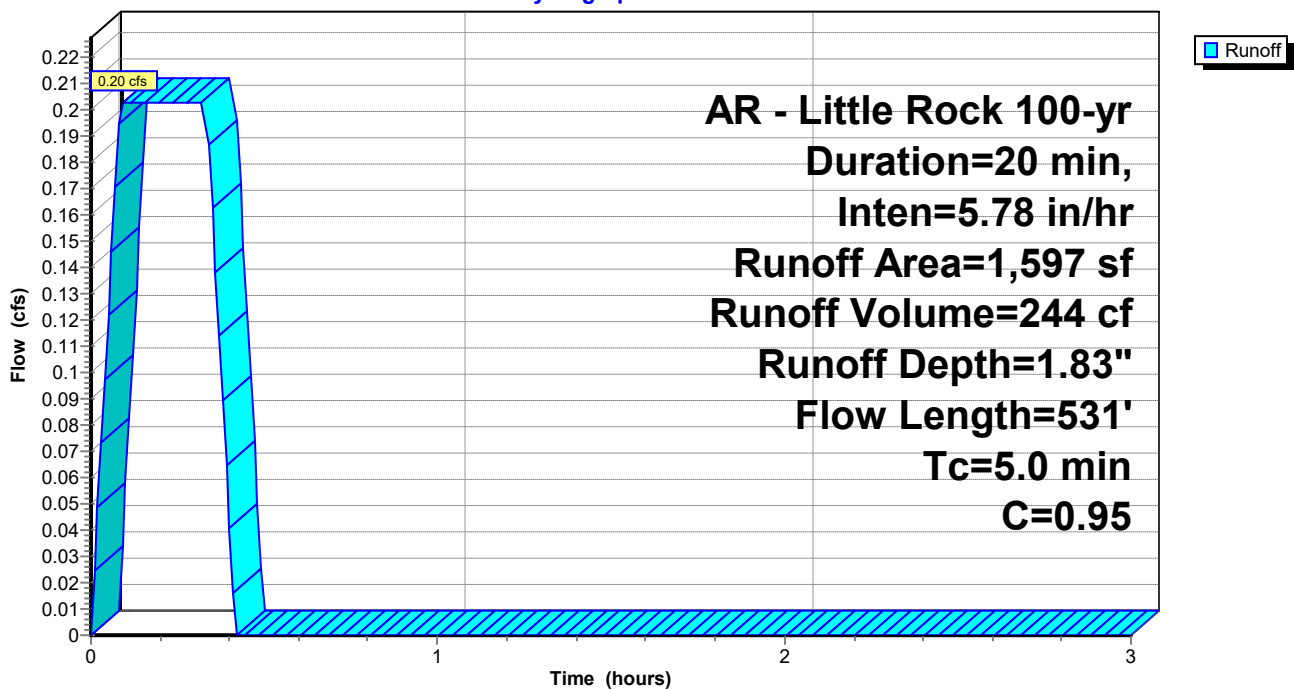

Summary for Subcatchment C8: Drainage Basin C8

Runoff = 0.20 cfs @ 0.09 hrs, Volume= 236 cf, Depth= 1.83"
 Routed to Pond CI-D2 : CI - D2

Runoff by Rational method, Rise/Fall=1.0/1.0 xTc, Time Span= 0.00-3.00 hrs, dt= 0.01 hrs
 AR - Little Rock 100-yr Duration=20 min, Inten=5.78 in/hr

Area (sf)	C	Description
0	0.40	Sod Yard
1,548	0.95	Paving, Sidewalks
1,548	0.95	Weighted Average
1,548		100.00% Impervious Area

Tc (min)	Length (feet)	Slope (ft/ft)	Velocity (ft/sec)	Capacity (cfs)	Description
0.3	18	0.0200	1.12		Sheet Flow, Sheet Flow Smooth surfaces n= 0.011 P2= 4.19"
0.3	94	0.0610	5.01		Shallow Concentrated Flow, Concentrated Flow Paved Kv= 20.3 fps
4.4	415		1.57		Direct Entry, Concentrated Flow (Min)
5.0	527	Total			

Subcatchment C8: Drainage Basin C8

Hydrograph

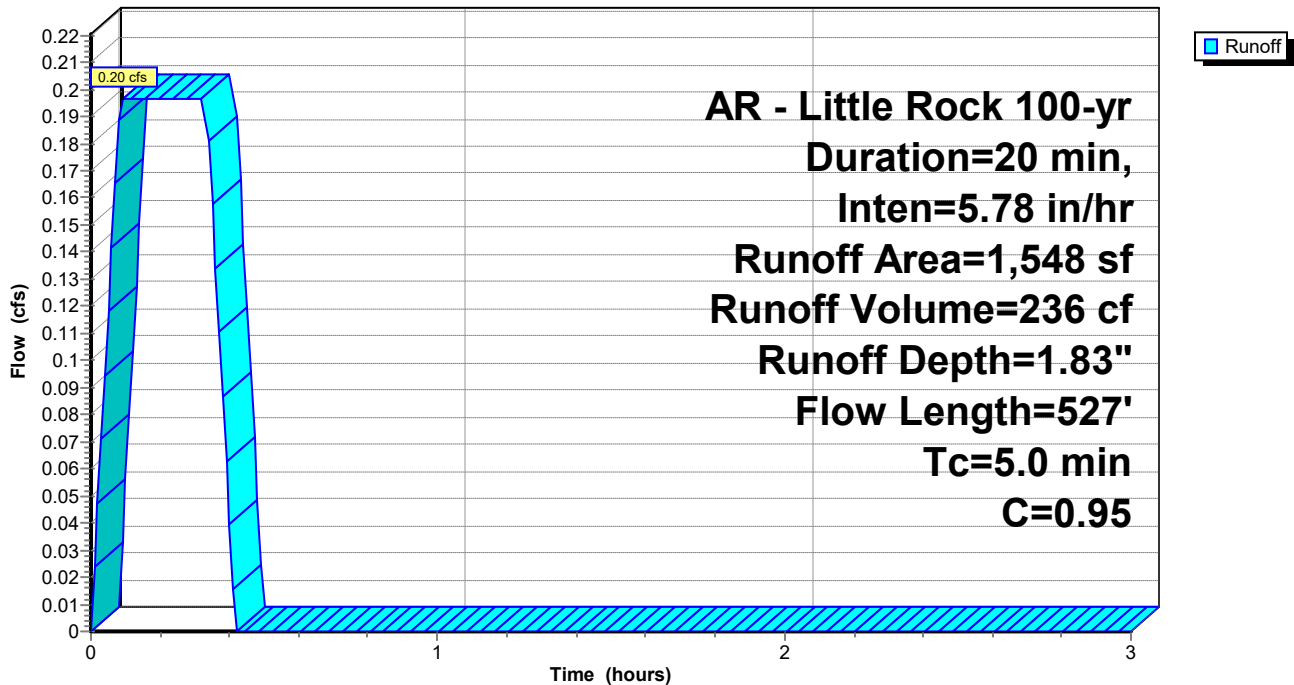

Goddard

Prepared by Phillip Lewis Engineering

HydroCAD® 10.20-5c s/n 12520 © 2023 HydroCAD Software Solutions LLC

AR - Little Rock 100-yr Duration=20 min, Inten=5.78 in/hr

Printed 3/25/2026

Summary for Subcatchment C9: Drainage Basin C9

Runoff = 1.42 cfs @ 0.09 hrs, Volume= 1,708 cf, Depth= 1.48"
 Routed to Pond CI-C6 : CI - C6

Runoff by Rational method, Rise/Fall=1.0/1.0 xTc, Time Span= 0.00-3.00 hrs, dt= 0.01 hrs
 AR - Little Rock 100-yr Duration=20 min, Inten=5.78 in/hr

Area (sf)	C	Description
4,456	0.40	Sod Yard
9,361	0.95	Paving, Sidewalks
13,817	0.77	Weighted Average
4,456		32.25% Pervious Area
9,361		67.75% Impervious Area

Tc (min)	Length (feet)	Slope (ft/ft)	Velocity (ft/sec)	Capacity (cfs)	Description
1.2	100	0.0140	1.36		Sheet Flow, Sheet Flow Smooth surfaces n= 0.011 P2= 4.19"
0.1	13	0.0150	2.49		Shallow Concentrated Flow, Concentrated Flow Paved Kv= 20.3 fps
0.1	23	0.0160	2.57		Shallow Concentrated Flow, Concentrated Flow Paved Kv= 20.3 fps
0.1	7	0.0050	1.44		Shallow Concentrated Flow, Concentrated Flow Paved Kv= 20.3 fps
0.1	8	0.0100	2.03		Shallow Concentrated Flow, Concentrated Flow Paved Kv= 20.3 fps
0.2	41	0.0420	4.16		Shallow Concentrated Flow, Concentrated Flow Paved Kv= 20.3 fps
0.1	41	0.0540	4.72		Shallow Concentrated Flow, Concentrated Flow Paved Kv= 20.3 fps
0.2	61	0.0520	4.63		Shallow Concentrated Flow, Concentrated Flow Paved Kv= 20.3 fps
2.9	415		2.39		Direct Entry, Concentrated Flow (Min)
5.0	709	Total			

Subcatchment C9: Drainage Basin C9

Hydrograph

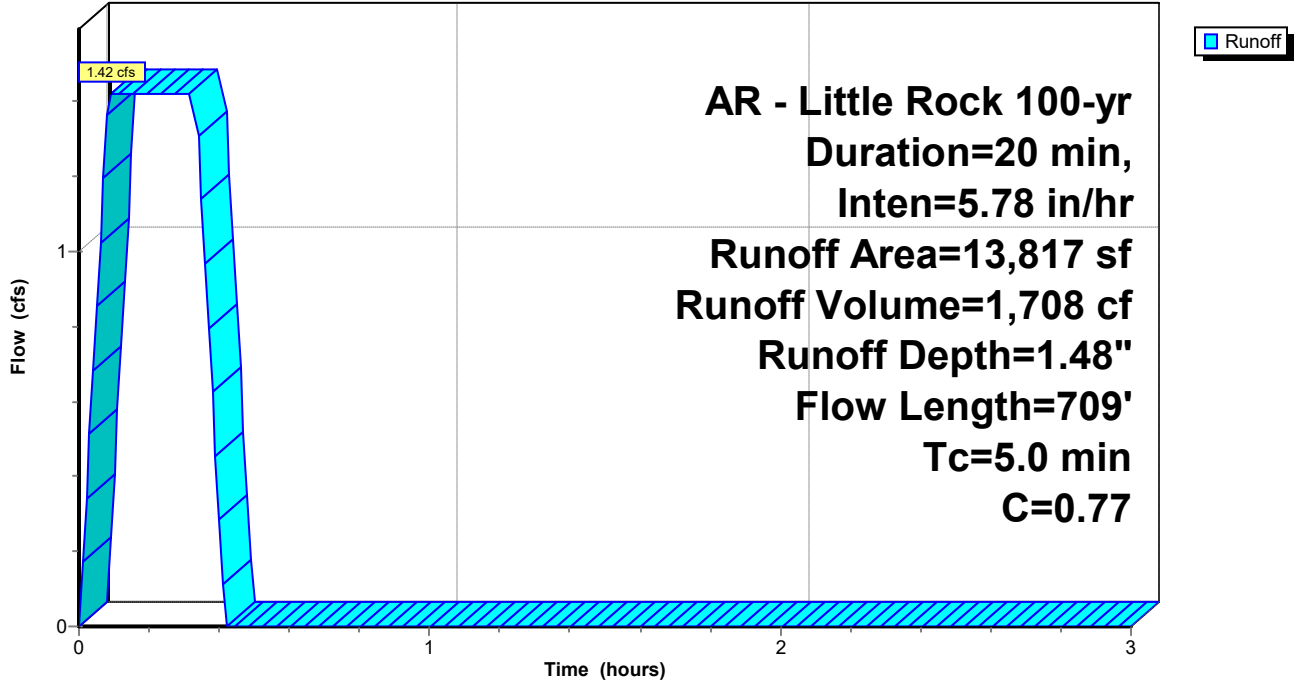

Summary for Pond CI-A1: CI - A1

Inflow Area = 19,493 sf, 74.78% Impervious, Inflow Depth = 1.62" for 100-yr event
Inflow = 2.19 cfs @ 0.09 hrs, Volume= 2,628 cf
Primary = 2.19 cfs @ 0.09 hrs, Volume= 2,628 cf, Atten= 0%, Lag= 0.0 min
Routed to Pond JB-A2 : JB - A2

Routing by Stor-Ind method, Time Span= 0.00-3.00 hrs, dt= 0.01 hrs

Pond CI-A1: CI - A1

Hydrograph

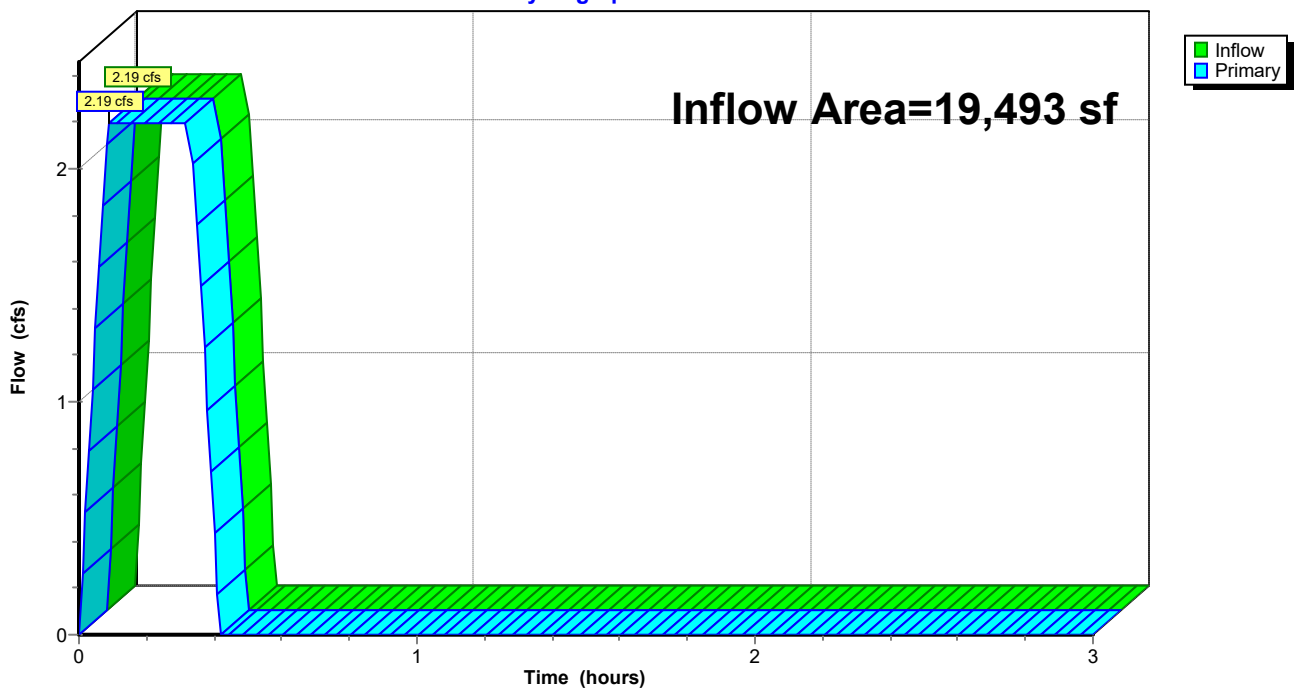

Summary for Pond CI-A3: CI - A3

Inflow Area = 52,824 sf, 61.20% Impervious, Inflow Depth = 1.50" for 100-yr event
Inflow = 5.51 cfs @ 0.17 hrs, Volume= 6,608 cf
Primary = 5.51 cfs @ 0.17 hrs, Volume= 6,608 cf, Atten= 0%, Lag= 0.0 min
Routed to Pond CI-A4 : CI - A4

Routing by Stor-Ind method, Time Span= 0.00-3.00 hrs, dt= 0.01 hrs

Pond CI-A3: CI - A3

Hydrograph

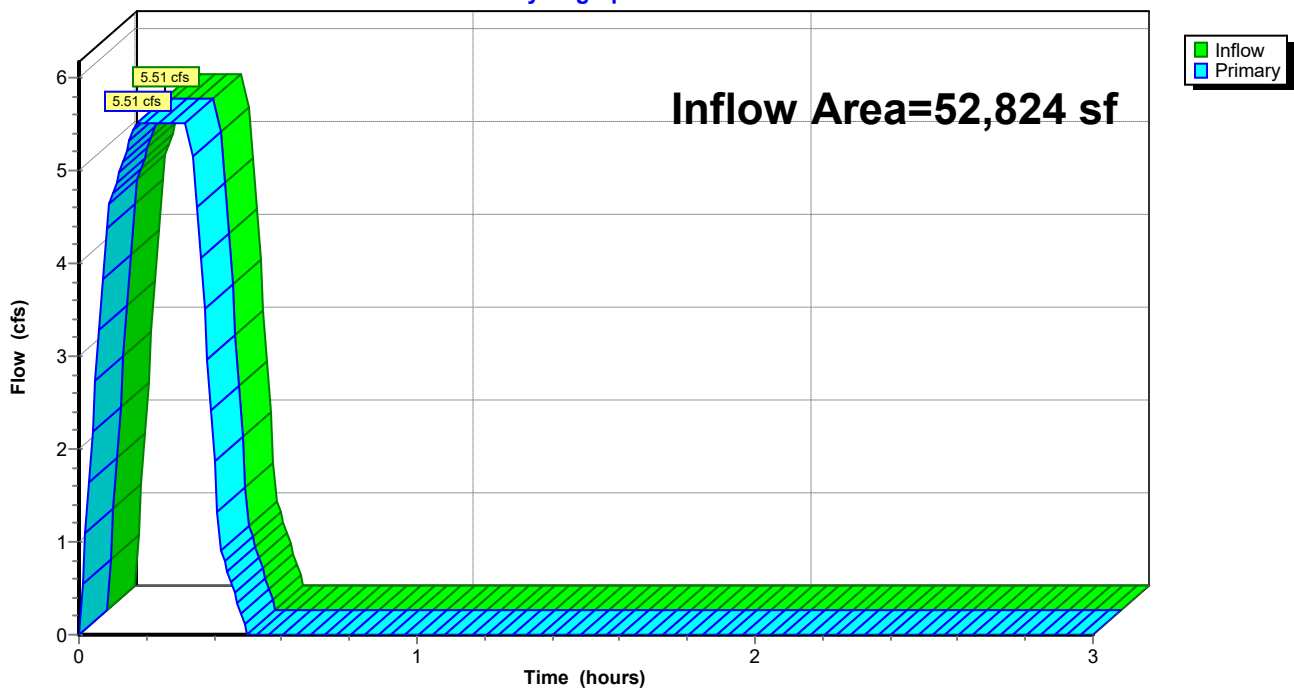

Summary for Pond CI-A4: CI - A4

Inflow Area = 75,210 sf, 60.06% Impervious, Inflow Depth = 1.49" for 100-yr event
Inflow = 7.77 cfs @ 0.24 hrs, Volume= 9,326 cf
Primary = 7.77 cfs @ 0.24 hrs, Volume= 9,326 cf, Atten= 0%, Lag= 0.0 min
Routed to Pond CI-A5 : CI - A5

Routing by Stor-Ind method, Time Span= 0.00-3.00 hrs, dt= 0.01 hrs

Pond CI-A4: CI - A4

Hydrograph

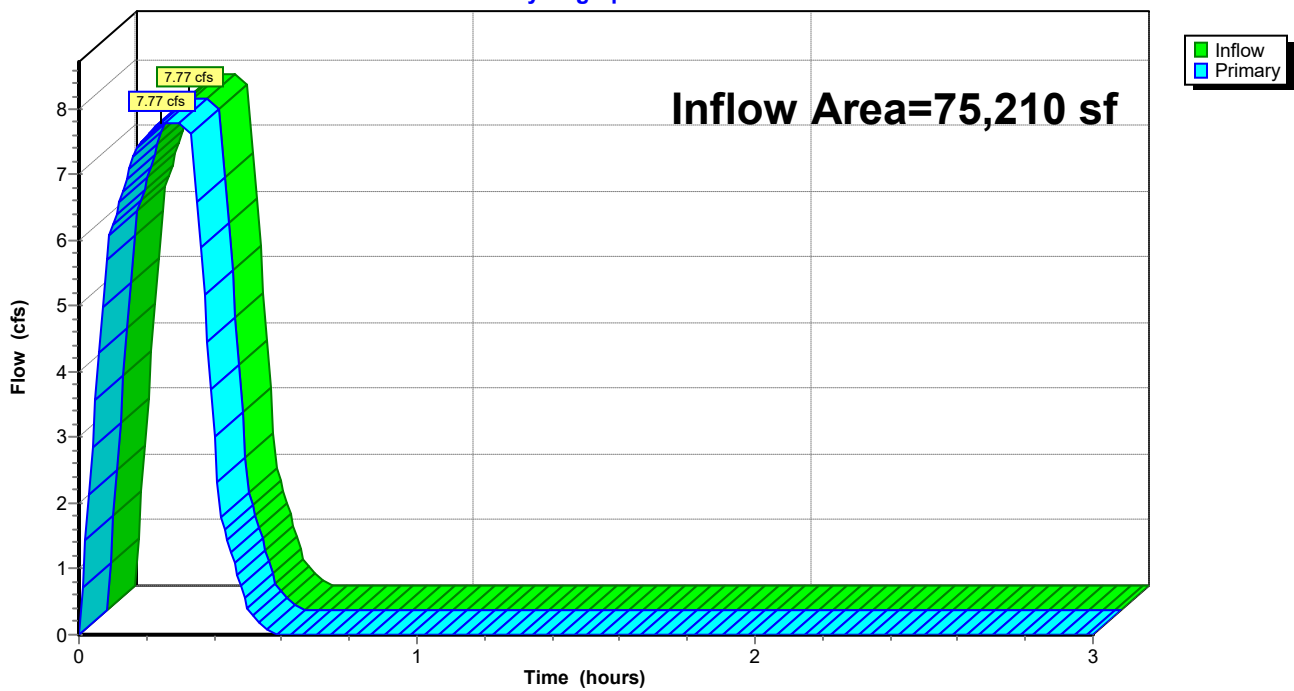

Summary for Pond CI-A5: CI - A5

Inflow Area = 97,235 sf, 62.81% Impervious, Inflow Depth = 1.50" for 100-yr event
Inflow = 10.13 cfs @ 0.27 hrs, Volume= 12,155 cf
Primary = 10.13 cfs @ 0.27 hrs, Volume= 12,155 cf, Atten= 0%, Lag= 0.0 min
Routed to Pond DP : Existing North Detention Pond

Routing by Stor-Ind method, Time Span= 0.00-3.00 hrs, dt= 0.01 hrs

Pond CI-A5: CI - A5

Hydrograph

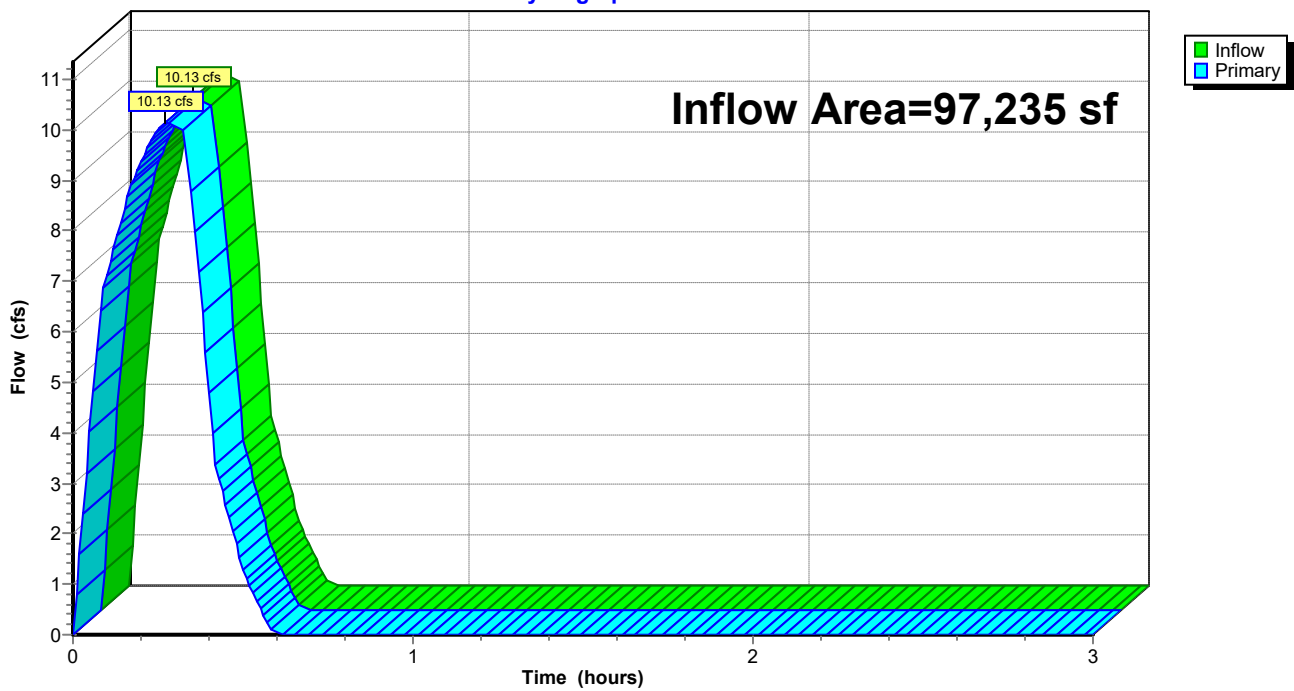

Summary for Pond CI-B2: CI - B2

Inflow Area = 22,169 sf, 29.72% Impervious, Inflow Depth = 1.23" for 100-yr event
Inflow = 1.90 cfs @ 0.17 hrs, Volume= 2,278 cf
Primary = 1.90 cfs @ 0.17 hrs, Volume= 2,278 cf, Atten= 0%, Lag= 0.0 min
Routed to Pond JB-A2 : JB - A2

Routing by Stor-Ind method, Time Span= 0.00-3.00 hrs, dt= 0.01 hrs

Pond CI-B2: CI - B2

Hydrograph

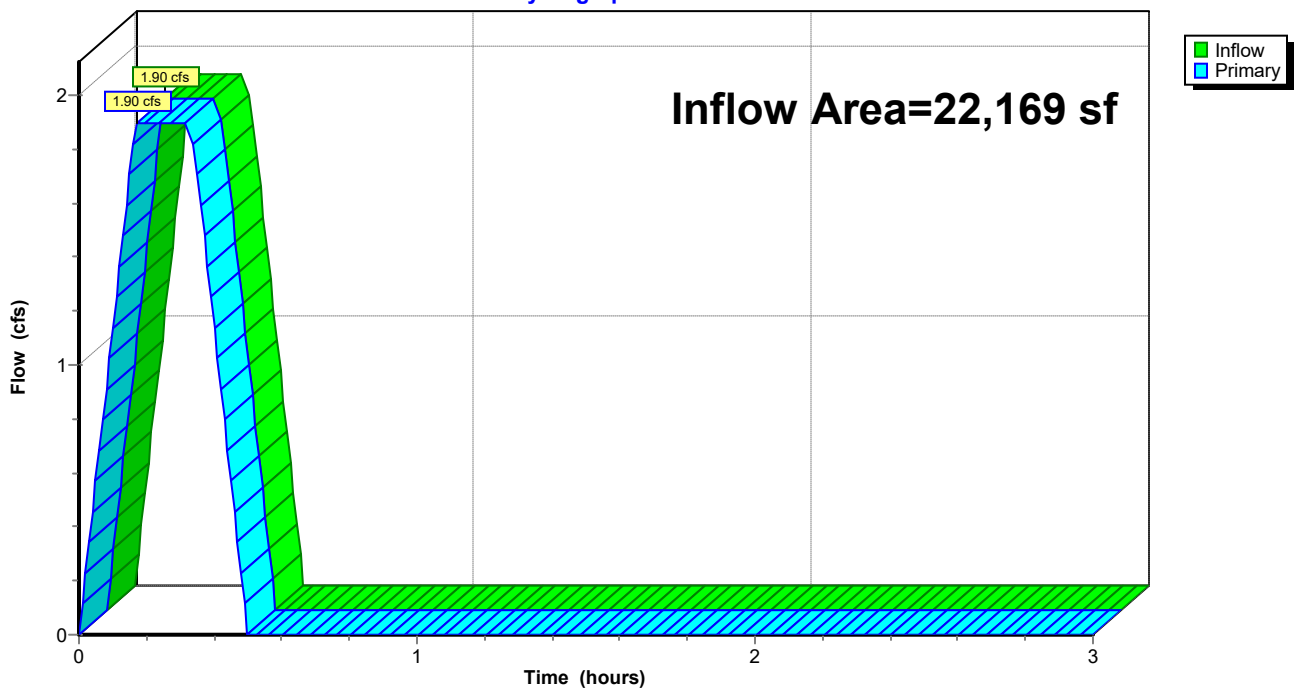

Summary for Pond CI-C1: CI - C1

Inflow Area = 20,337 sf, 69.83% Impervious, Inflow Depth = 1.50" for 100-yr event
Inflow = 2.12 cfs @ 0.09 hrs, Volume= 2,545 cf
Primary = 2.12 cfs @ 0.09 hrs, Volume= 2,545 cf, Atten= 0%, Lag= 0.0 min
Routed to Pond CI-C2 : CI - C2

Routing by Stor-Ind method, Time Span= 0.00-3.00 hrs, dt= 0.01 hrs

Pond CI-C1: CI - C1

Hydrograph

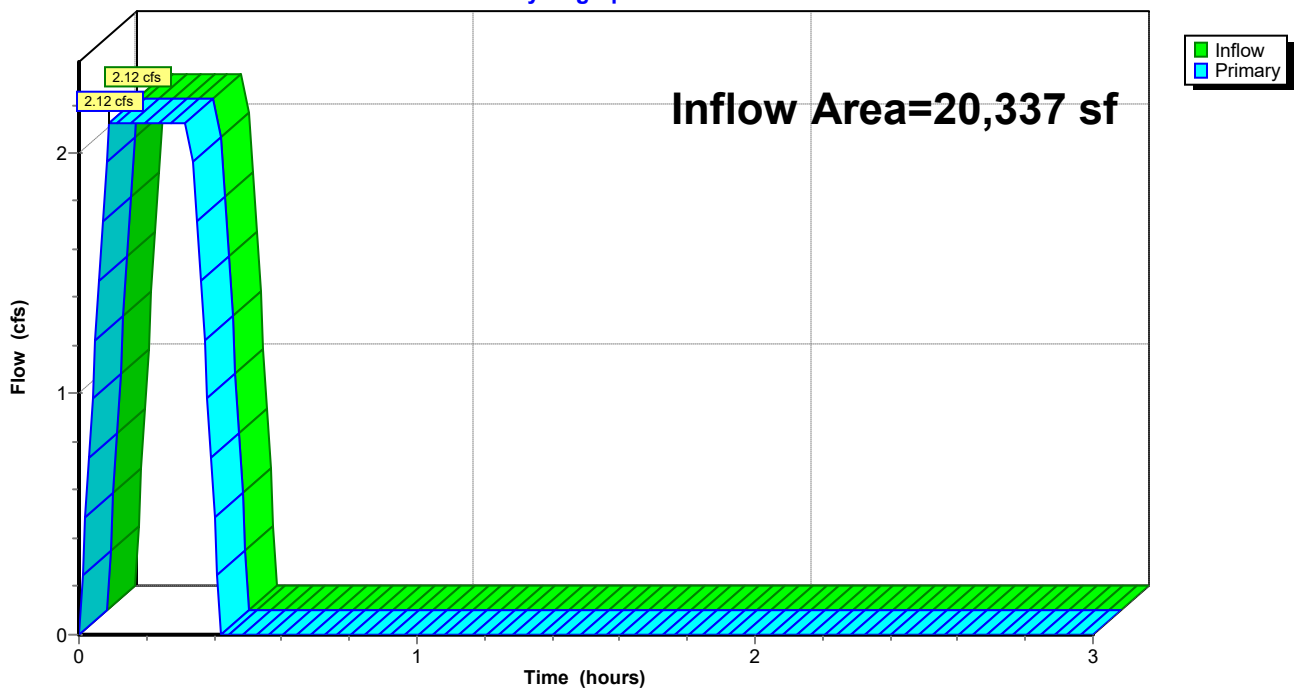

Summary for Pond CI-C2: CI - C2

Inflow Area = 54,676 sf, 67.97% Impervious, Inflow Depth = 1.49" for 100-yr event
Inflow = 5.66 cfs @ 0.09 hrs, Volume= 6,790 cf
Primary = 5.66 cfs @ 0.09 hrs, Volume= 6,790 cf, Atten= 0%, Lag= 0.0 min
Routed to Pond CI-C3 : CI - C3

Routing by Stor-Ind method, Time Span= 0.00-3.00 hrs, dt= 0.01 hrs

Pond CI-C2: CI - C2

Hydrograph

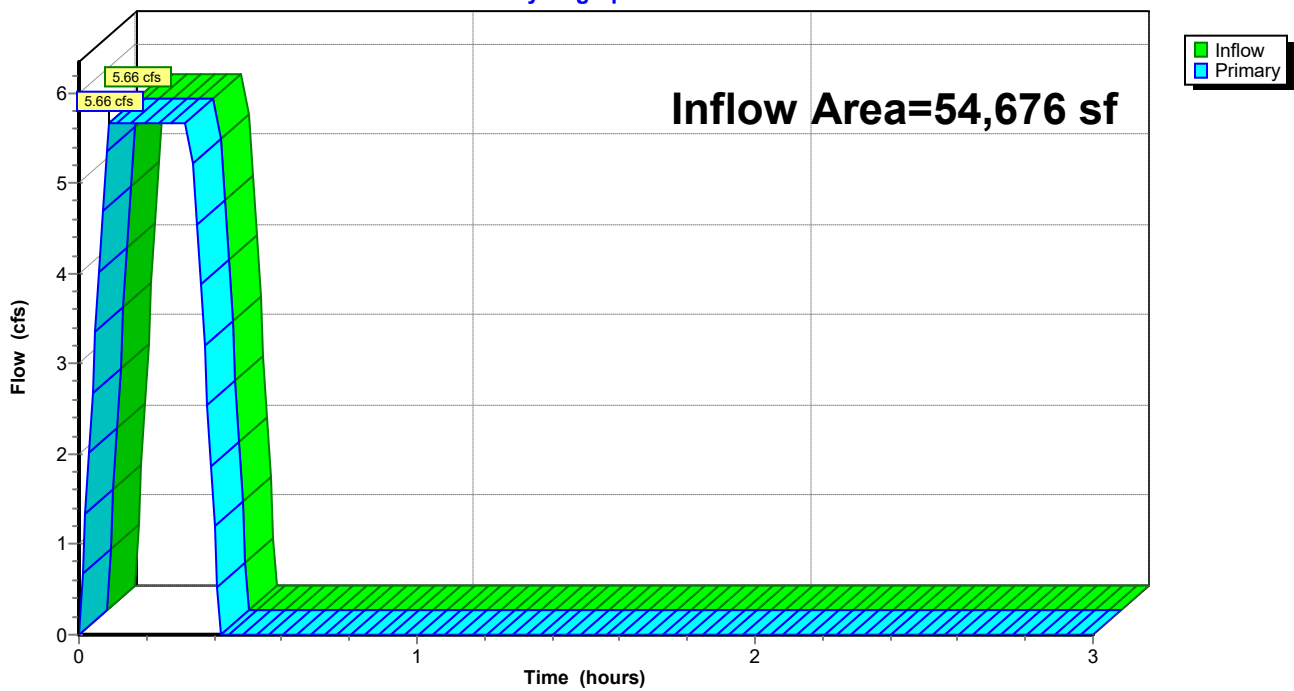

Summary for Pond CI-C3: CI - C3

Inflow Area = 69,531 sf, 63.12% Impervious, Inflow Depth = 1.44" for 100-yr event
Inflow = 6.96 cfs @ 0.09 hrs, Volume= 8,343 cf
Primary = 6.96 cfs @ 0.09 hrs, Volume= 8,343 cf, Atten= 0%, Lag= 0.0 min
Routed to Pond CI-C4 : CI - C4

Routing by Stor-Ind method, Time Span= 0.00-3.00 hrs, dt= 0.01 hrs

Pond CI-C3: CI - C3

Hydrograph

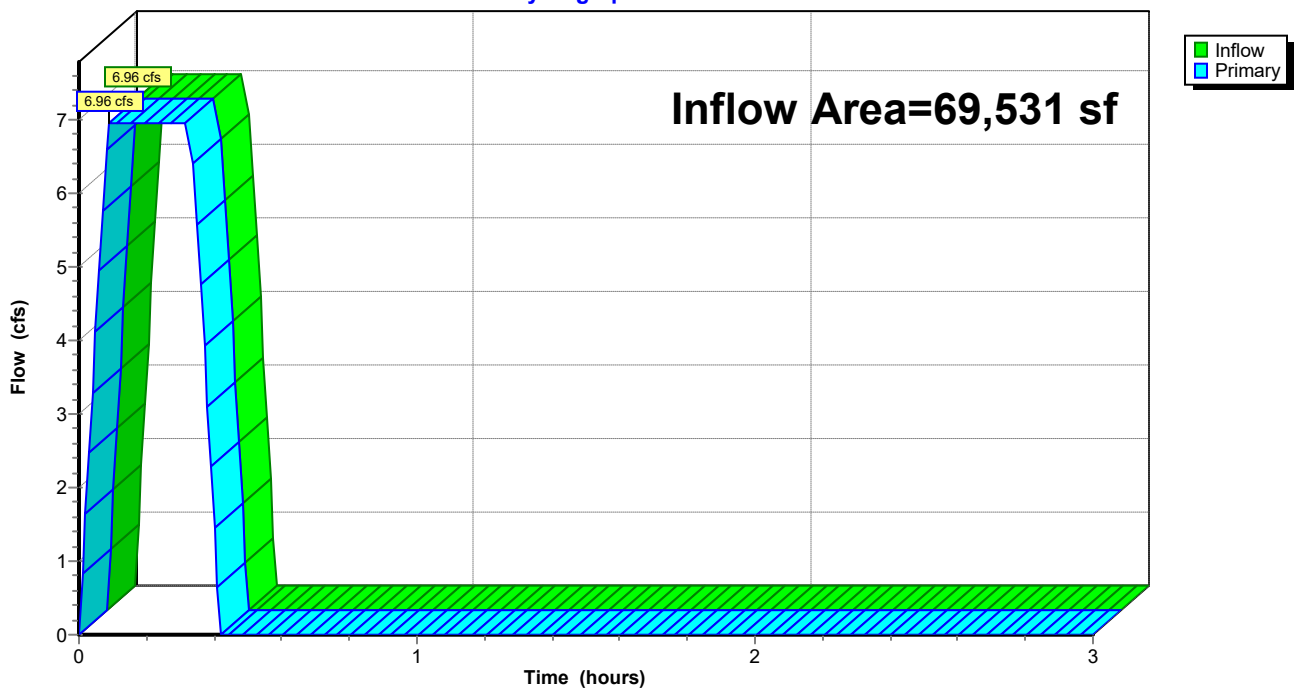

Summary for Pond CI-C4: CI - C4

Inflow Area = 76,226 sf, 64.22% Impervious, Inflow Depth = 1.45" for 100-yr event
Inflow = 7.69 cfs @ 0.10 hrs, Volume= 9,225 cf
Primary = 7.69 cfs @ 0.10 hrs, Volume= 9,225 cf, Atten= 0%, Lag= 0.0 min
Routed to Pond CI-C5 : CI - C5

Routing by Stor-Ind method, Time Span= 0.00-3.00 hrs, dt= 0.01 hrs

Pond CI-C4: CI - C4

Hydrograph

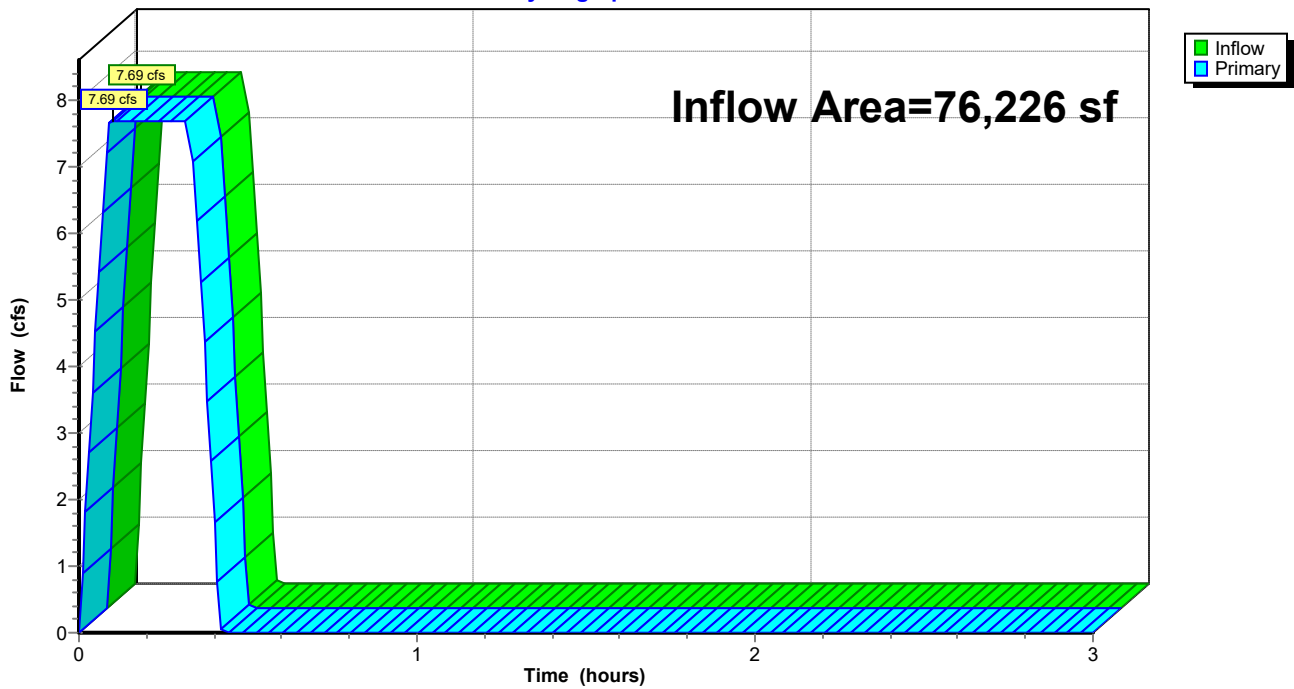

Summary for Pond CI-C5: CI - C5

Inflow Area = 79,061 sf, 65.50% Impervious, Inflow Depth = 1.47" for 100-yr event
Inflow = 8.05 cfs @ 0.10 hrs, Volume= 9,657 cf
Primary = 8.05 cfs @ 0.10 hrs, Volume= 9,657 cf, Atten= 0%, Lag= 0.0 min
Routed to Pond CI-C6 : CI - C6

Routing by Stor-Ind method, Time Span= 0.00-3.00 hrs, dt= 0.01 hrs

Pond CI-C5: CI - C5

Hydrograph

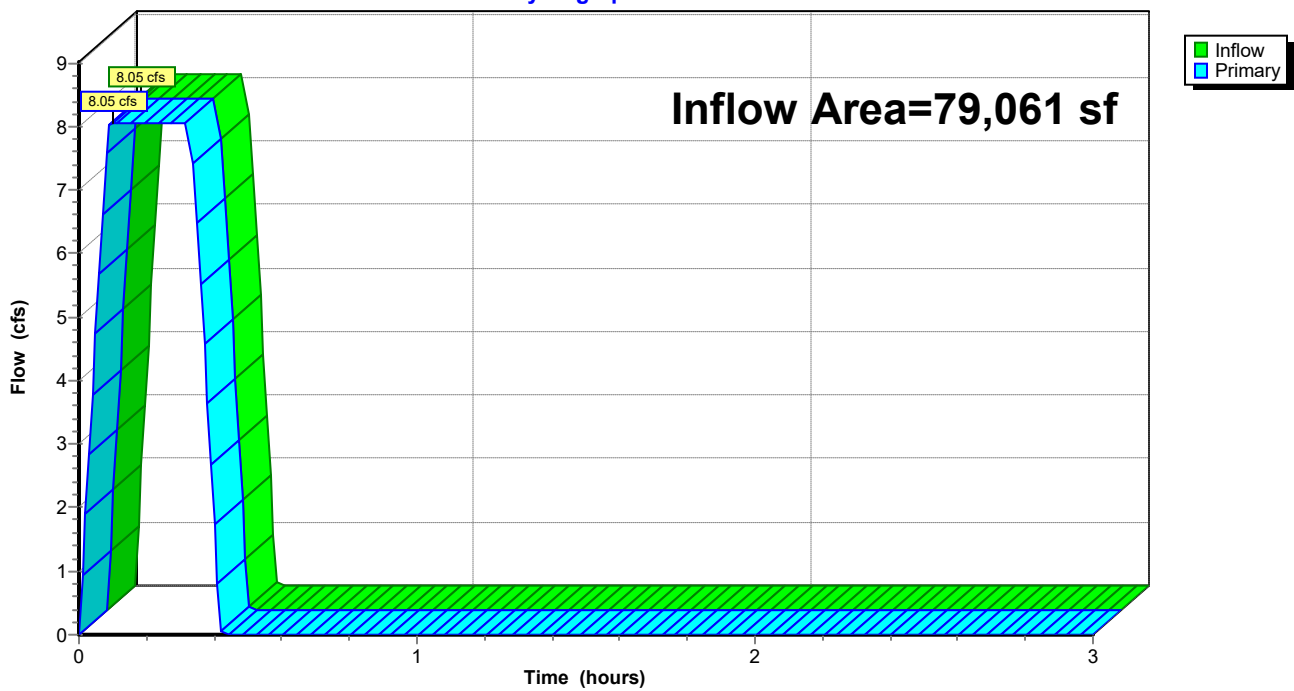

Summary for Pond CI-C6: CI - C6

Inflow Area = 96,023 sf, 66.95% Impervious, Inflow Depth = 1.48" for 100-yr event
Inflow = 9.88 cfs @ 0.10 hrs, Volume= 11,844 cf
Primary = 9.88 cfs @ 0.10 hrs, Volume= 11,844 cf, Atten= 0%, Lag= 0.0 min
Routed to Pond CI-C7 : CI - C7

Routing by Stor-Ind method, Time Span= 0.00-3.00 hrs, dt= 0.01 hrs

Pond CI-C6: CI - C6

Hydrograph

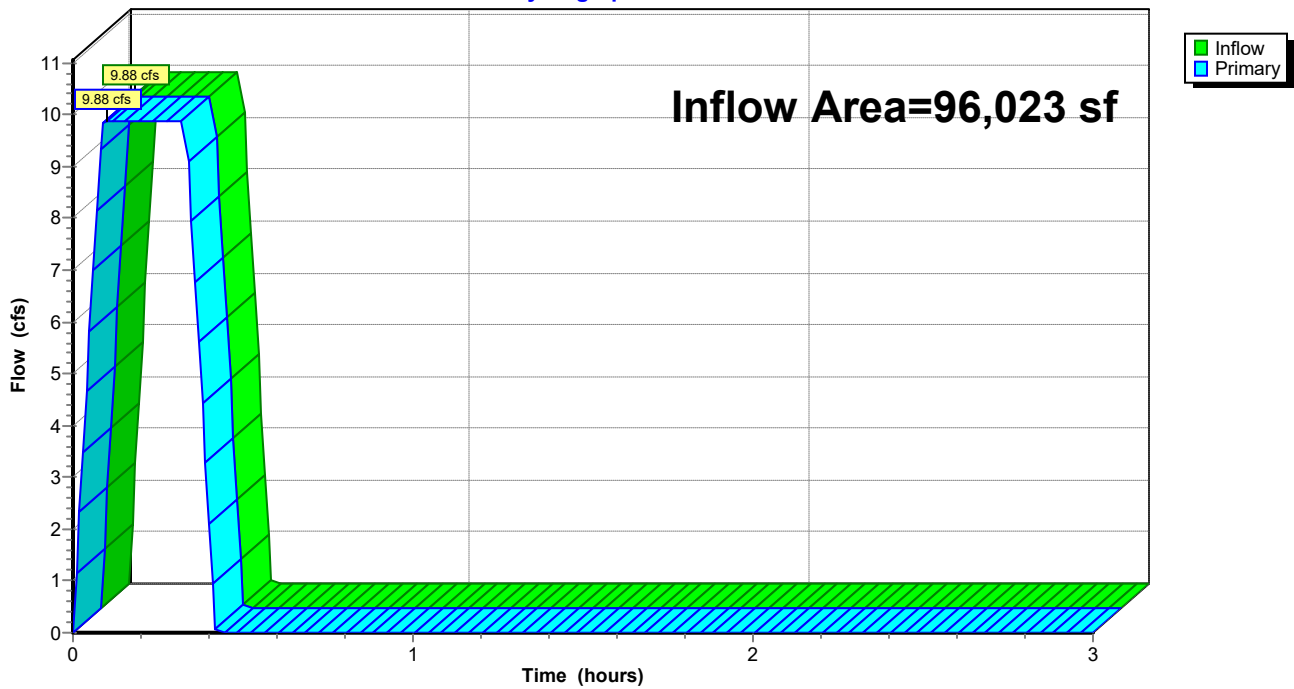

Summary for Pond CI-C7: CI - C7

Inflow Area = 133,272 sf, 67.70% Impervious, Inflow Depth = 1.49" for 100-yr event
Inflow = 13.79 cfs @ 0.10 hrs, Volume= 16,545 cf
Primary = 13.79 cfs @ 0.10 hrs, Volume= 16,545 cf, Atten= 0%, Lag= 0.0 min
Routed to Pond DP : Existing North Detention Pond

Routing by Stor-Ind method, Time Span= 0.00-3.00 hrs, dt= 0.01 hrs

Pond CI-C7: CI - C7

Hydrograph

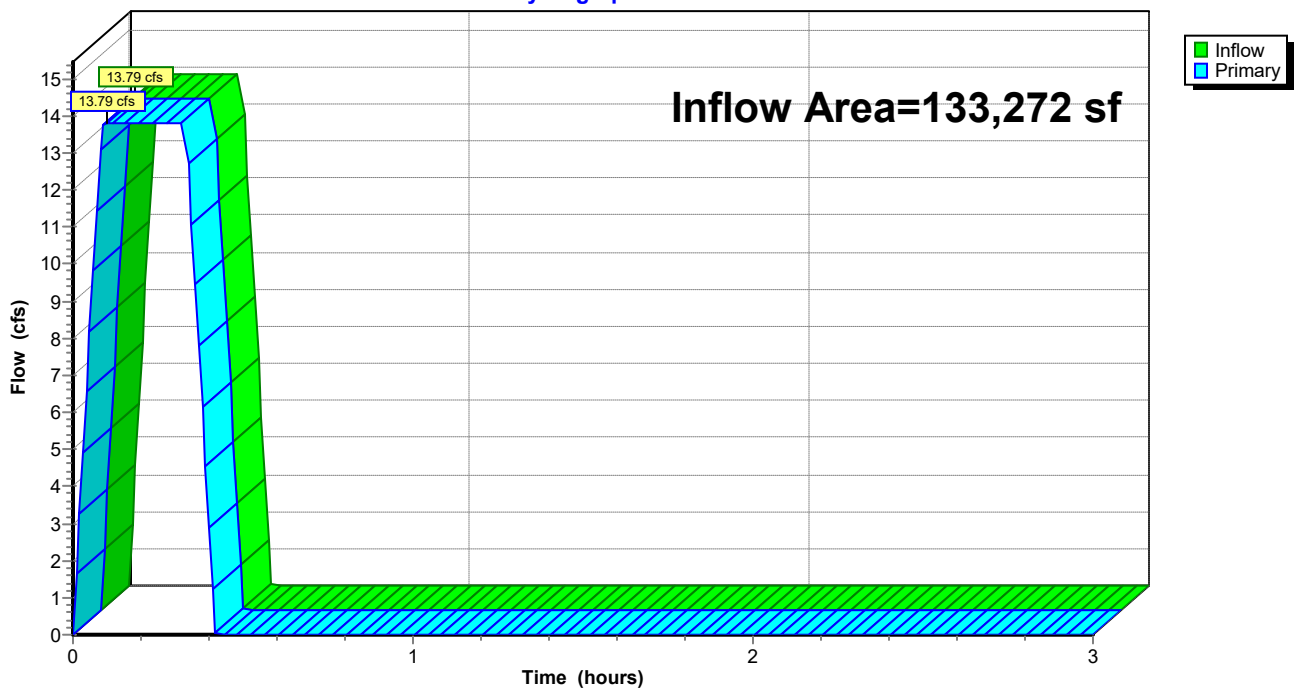

Summary for Pond CI-D1: CI - D1

Inflow Area = 1,597 sf, 100.00% Impervious, Inflow Depth = 1.83" for 100-yr event
Inflow = 0.20 cfs @ 0.09 hrs, Volume= 244 cf
Primary = 0.20 cfs @ 0.09 hrs, Volume= 244 cf, Atten= 0%, Lag= 0.0 min
Routed to Pond CI-D2 : CI - D2

Routing by Stor-Ind method, Time Span= 0.00-3.00 hrs, dt= 0.01 hrs

Pond CI-D1: CI - D1

Hydrograph

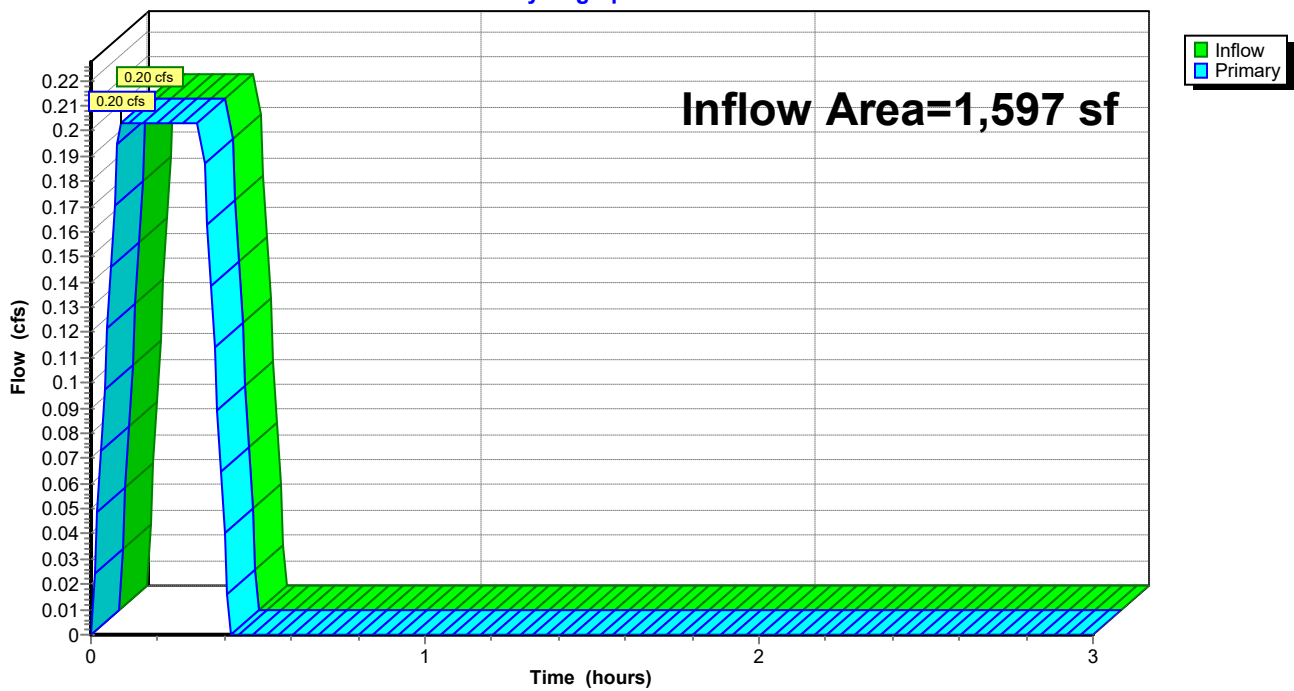

Summary for Pond CI-D2: CI - D2

Inflow Area = 3,145 sf, 100.00% Impervious, Inflow Depth = 1.83" for 100-yr event
Inflow = 0.40 cfs @ 0.09 hrs, Volume= 480 cf
Primary = 0.40 cfs @ 0.09 hrs, Volume= 480 cf, Atten= 0%, Lag= 0.0 min
Routed to Pond CI-C6 : CI - C6

Routing by Stor-Ind method, Time Span= 0.00-3.00 hrs, dt= 0.01 hrs

Pond CI-D2: CI - D2

Hydrograph

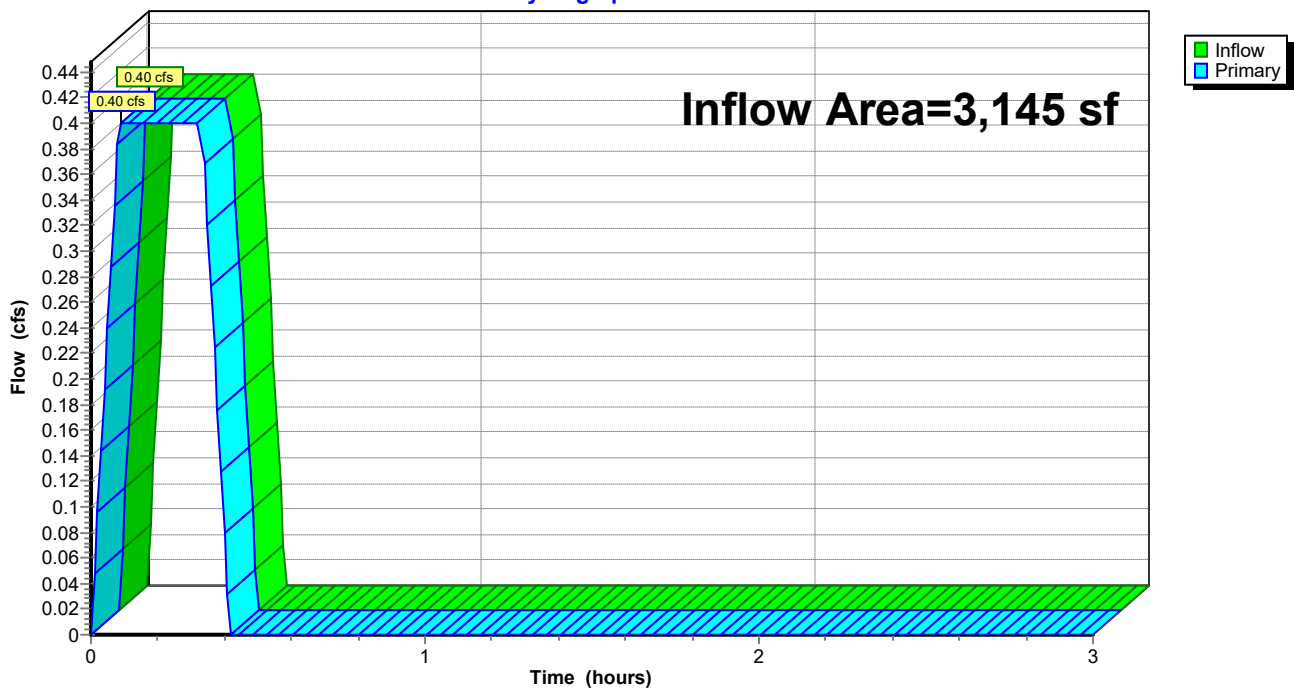

Summary for Pond CI-E1: CI - E1

Inflow Area = 5,408 sf, 77.35% Impervious, Inflow Depth = 1.60" for 100-yr event
Inflow = 0.60 cfs @ 0.09 hrs, Volume= 721 cf
Primary = 0.60 cfs @ 0.09 hrs, Volume= 721 cf, Atten= 0%, Lag= 0.0 min
Routed to Pond CI-E2 : CI - E2

Routing by Stor-Ind method, Time Span= 0.00-3.00 hrs, dt= 0.01 hrs

Pond CI-E1: CI - E1

Hydrograph

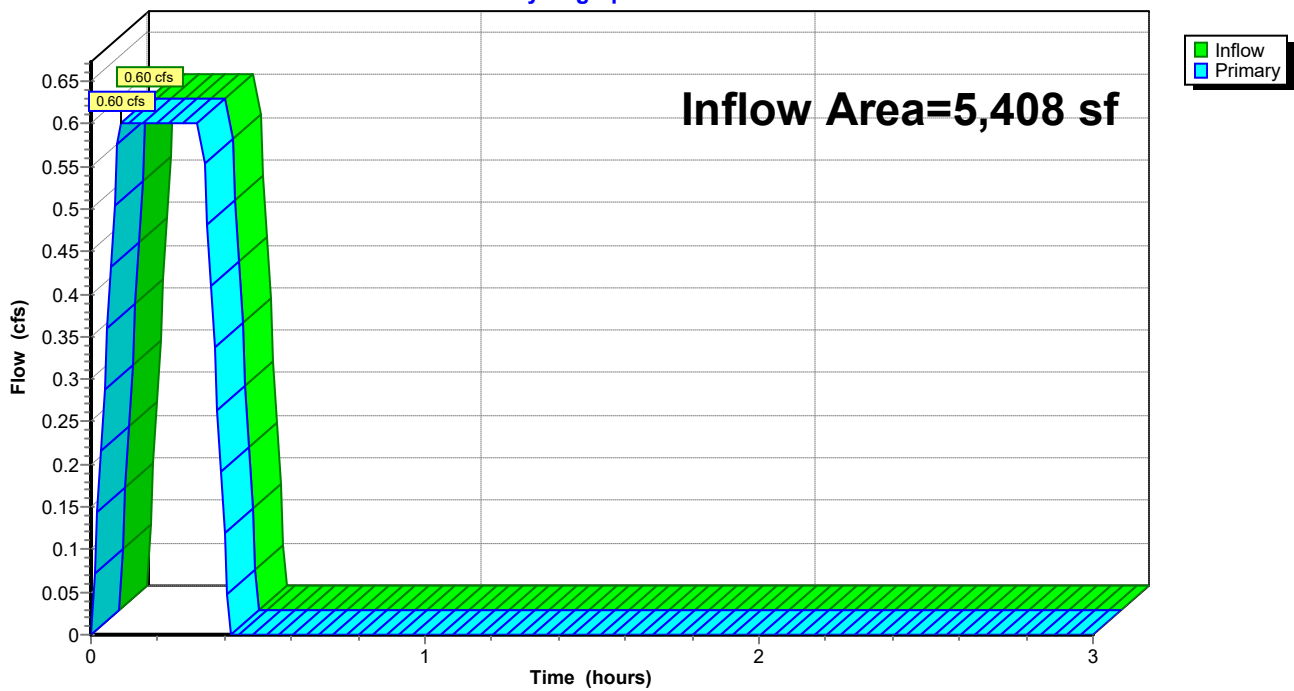

Summary for Pond CI-E2: CI - E2

Inflow Area = 11,591 sf, 64.62% Impervious, Inflow Depth = 1.45" for 100-yr event
Inflow = 1.17 cfs @ 0.09 hrs, Volume= 1,405 cf
Primary = 1.17 cfs @ 0.09 hrs, Volume= 1,405 cf, Atten= 0%, Lag= 0.0 min
Routed to Pond CI-C7 : CI - C7

Routing by Stor-Ind method, Time Span= 0.00-3.00 hrs, dt= 0.01 hrs

Pond CI-E2: CI - E2

Hydrograph

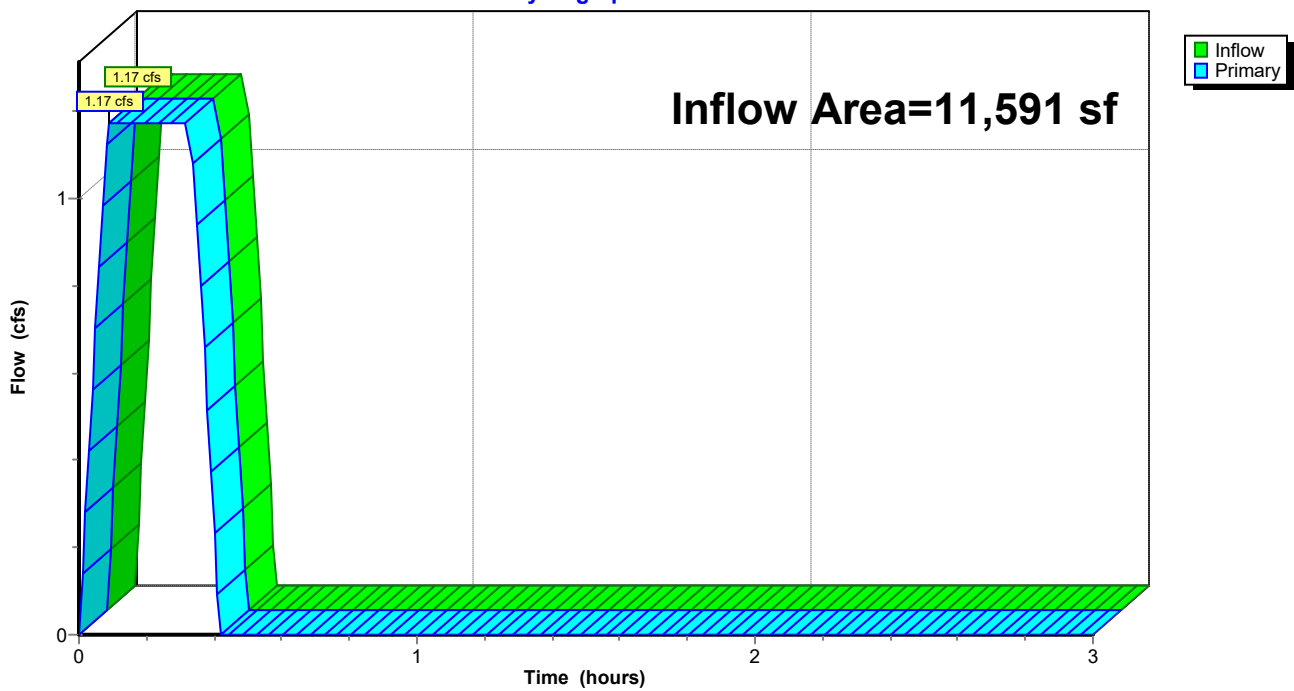

Goddard

AR - Little Rock 100-yr Duration=20 min, Inten=5.78 in/hr

Prepared by Phillip Lewis Engineering

Printed 3/25/2026

HydroCAD® 10.20-5c s/n 12520 © 2023 HydroCAD Software Solutions LLC

Summary for Pond DP: Existing North Detention Pond

Inflow Area = 322,783 sf, 53.09% Impervious, Inflow Depth = 1.35" for 100-yr event
 Inflow = 30.33 cfs @ 0.27 hrs, Volume= 36,381 cf
 Outflow = 12.52 cfs @ 0.39 hrs, Volume= 36,381 cf, Atten= 59%, Lag= 7.3 min
 Primary = 12.52 cfs @ 0.39 hrs, Volume= 36,381 cf
 Routed to Link FINAL : APPROX DISCHARGE

Routing by Stor-Ind method, Time Span= 0.00-3.00 hrs, dt= 0.01 hrs
 Peak Elev= 383.24' @ 0.39 hrs Storage= 23,171 cf

Plug-Flow detention time= 22.0 min calculated for 36,260 cf (100% of inflow)
 Center-of-Mass det. time= 22.1 min (35.7 - 13.5)

Volume	Invert	Avail.Storage	Storage Description
#1	381.17'	72,742 cf	Custom Stage Data Listed below

Elevation (feet)	Inc.Store (cubic-feet)	Cum.Store (cubic-feet)
381.17	0	0
381.50	200	200
382.00	1,825	2,025
382.50	5,265	7,290
383.00	9,300	16,590
383.50	13,733	30,323
384.00	18,578	48,901
384.50	23,841	72,742

Device	Routing	Invert	Outlet Devices
#1	Primary	384.16'	5.0' long Sharp-Crested Rectangular Weir 2 End Contraction(s)
#2	Primary	381.17'	1.7' long Sharp-Crested Rectangular Weir 2 End Contraction(s)

Primary OutFlow Max=12.52 cfs @ 0.39 hrs HW=383.24' (Free Discharge)

↑ **1=Sharp-Crested Rectangular Weir** (Controls 0.00 cfs)

└ **2=Sharp-Crested Rectangular Weir** (Weir Controls 12.52 cfs @ 4.70 fps)

Pond DP: Existing North Detention Pond

Hydrograph

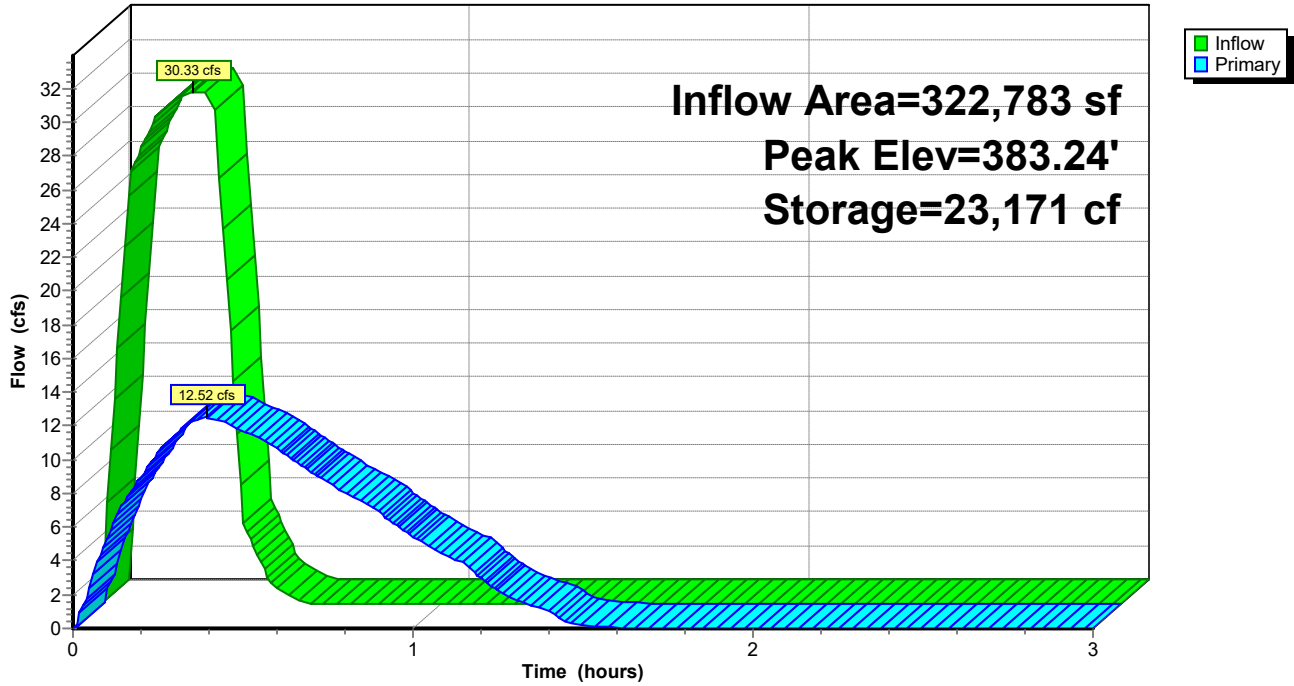

Summary for Pond JB-A2: JB - A2

Inflow Area = 50,937 sf, 59.76% Impervious, Inflow Depth = 1.49" for 100-yr event
Inflow = 5.27 cfs @ 0.17 hrs, Volume= 6,321 cf
Primary = 5.27 cfs @ 0.17 hrs, Volume= 6,321 cf, Atten= 0%, Lag= 0.0 min
Routed to Pond CI-A3 : CI - A3

Routing by Stor-Ind method, Time Span= 0.00-3.00 hrs, dt= 0.01 hrs

Pond JB-A2: JB - A2

Hydrograph

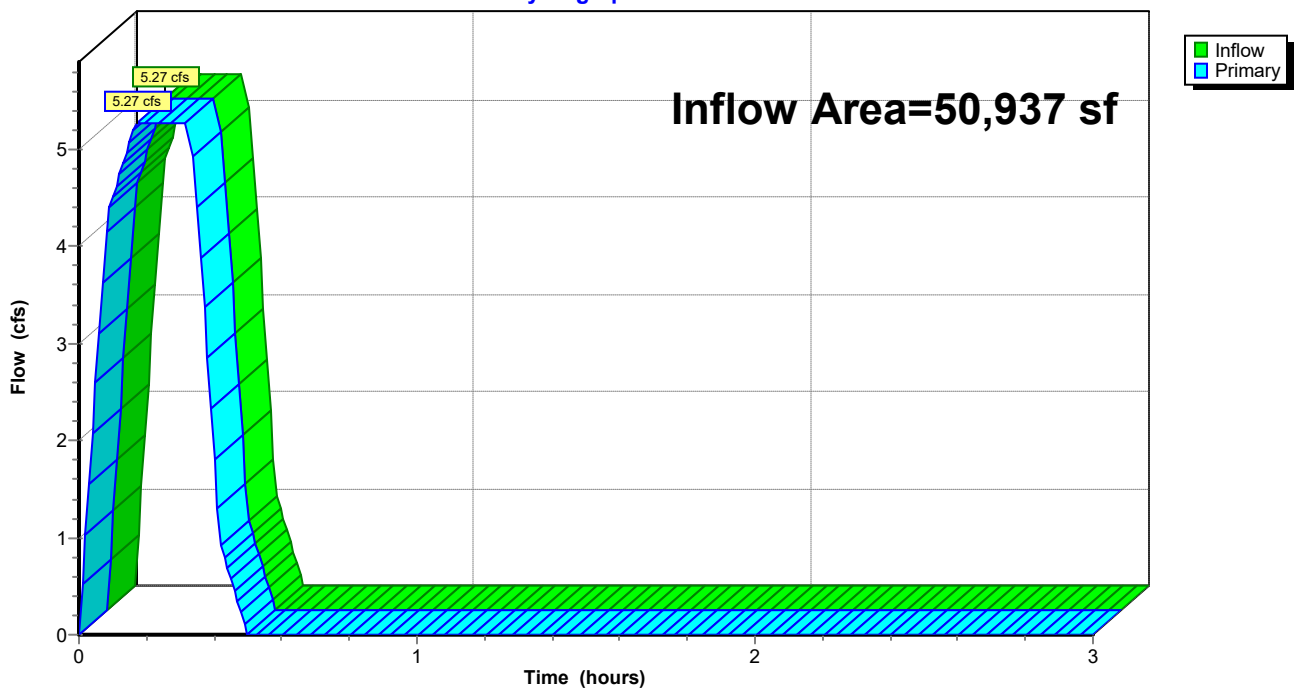

Summary for Link FINAL: APPROX DISCHARGE

Inflow Area = 509,184 sf, 38.62% Impervious, Inflow Depth = 1.24" for 100-yr event
Inflow = 25.43 cfs @ 0.33 hrs, Volume= 52,525 cf
Primary = 25.43 cfs @ 0.33 hrs, Volume= 52,525 cf, Atten= 0%, Lag= 0.0 min

Primary outflow = Inflow, Time Span= 0.00-3.00 hrs, dt= 0.01 hrs

Link FINAL: APPROX DISCHARGE

Hydrograph

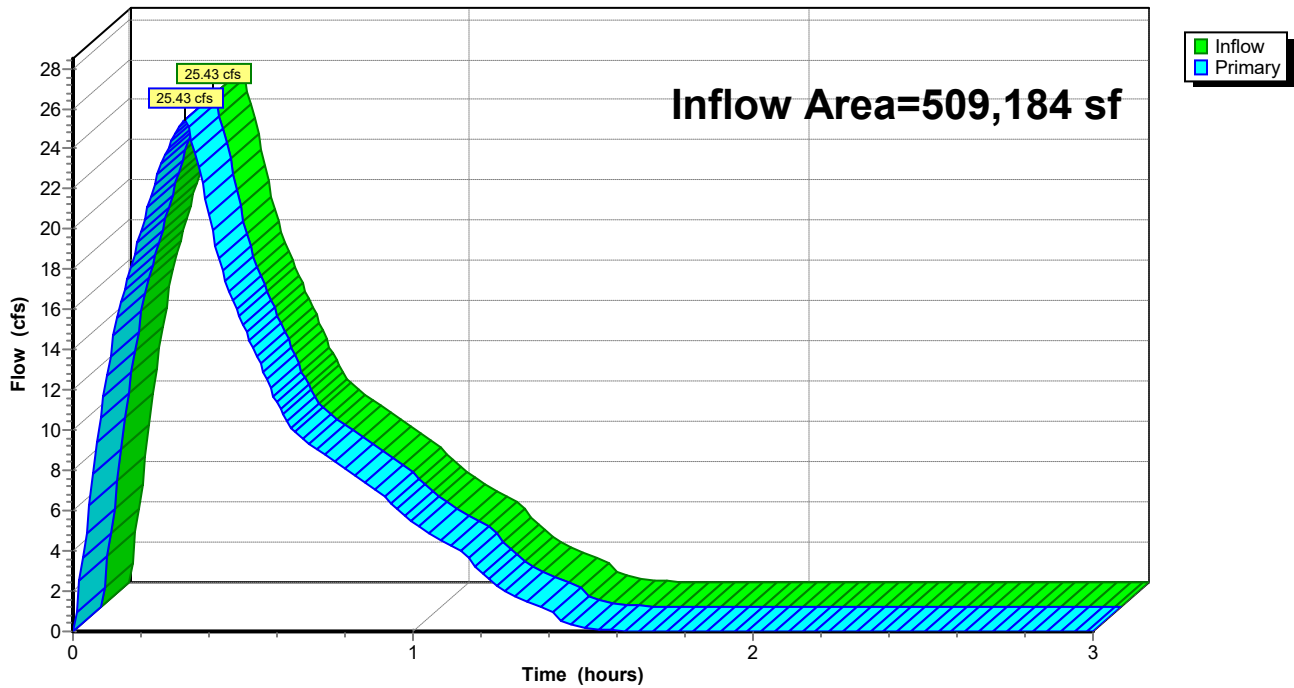

STORM SEWER ANALYSIS

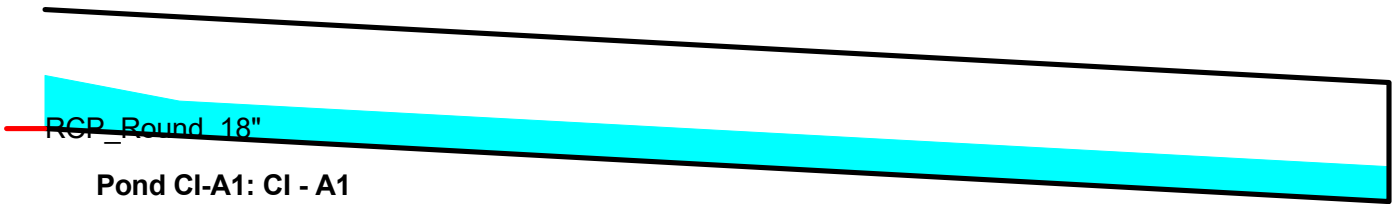

Pond CI-A1: CI - A1

Pond CI-A1: CI - A1

Hydrograph

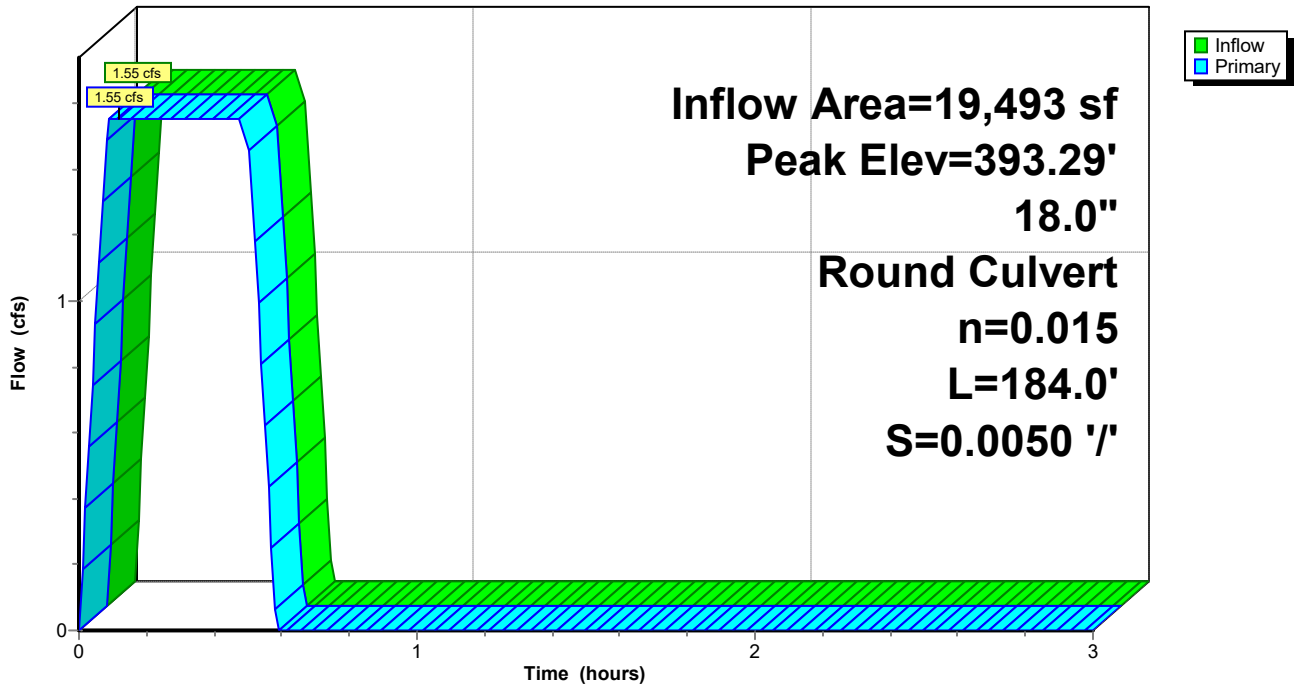

Goddard

Prepared by Phillip Lewis Engineering

HydroCAD® 10.20-5c s/n 12520 © 2023 HydroCAD Software Solutions LLC

AR - Little Rock 25-yr Duration=30 min, Inten=4.10 in/hr

Printed 3/26/2026

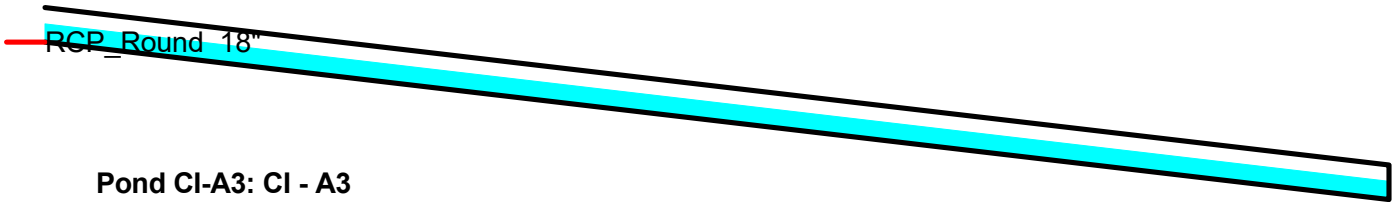

Pond CI-A3: CI - A3

Pond CI-A3: CI - A3

Hydrograph

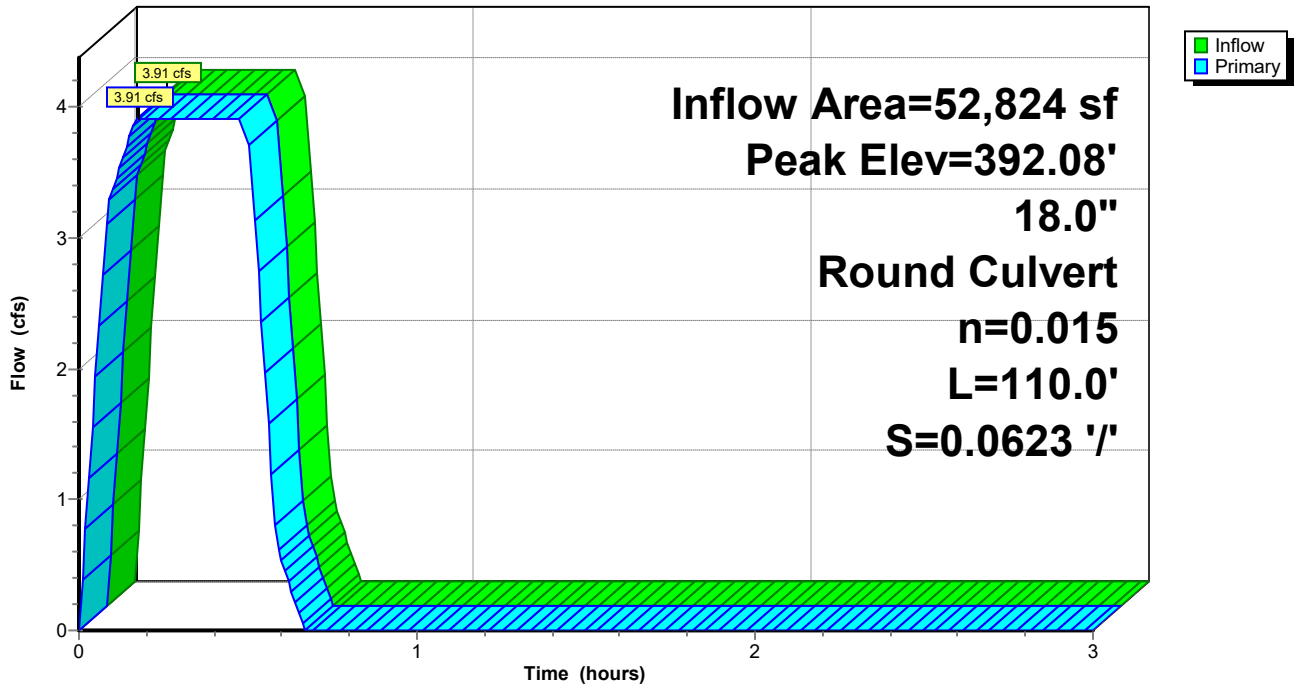

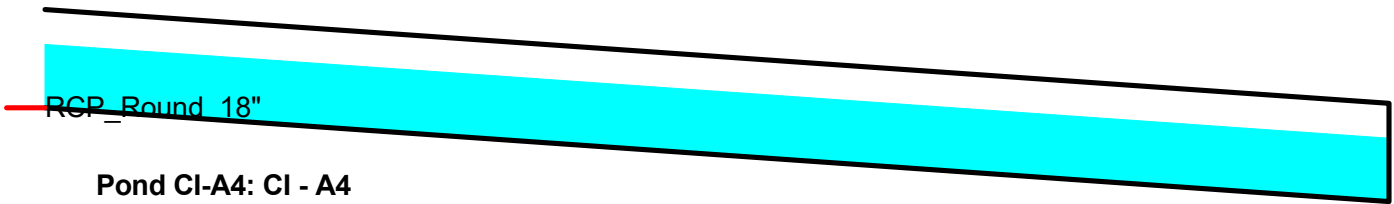

Pond CI-A4: CI - A4

Pond CI-A4: CI - A4

Hydrograph

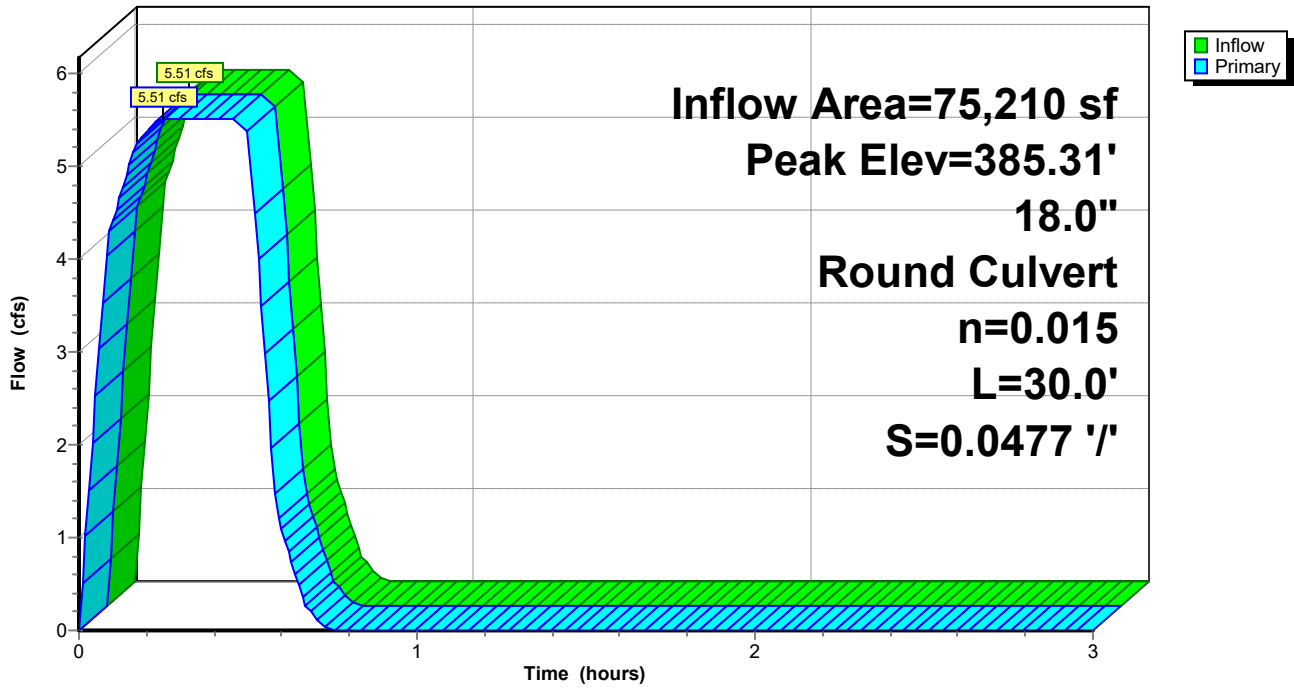

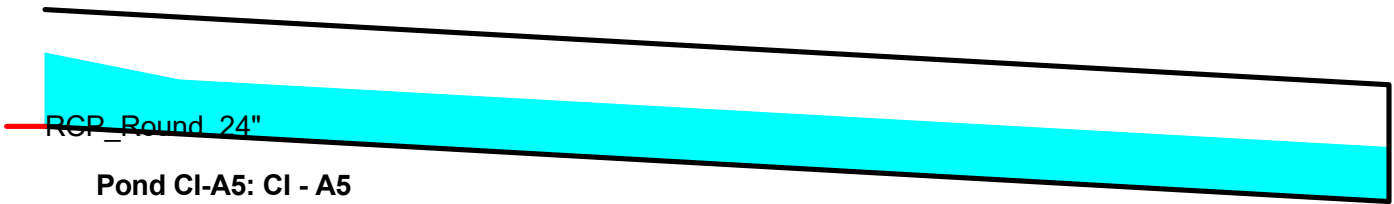

Pond CI-A5: CI - A5

Hydrograph

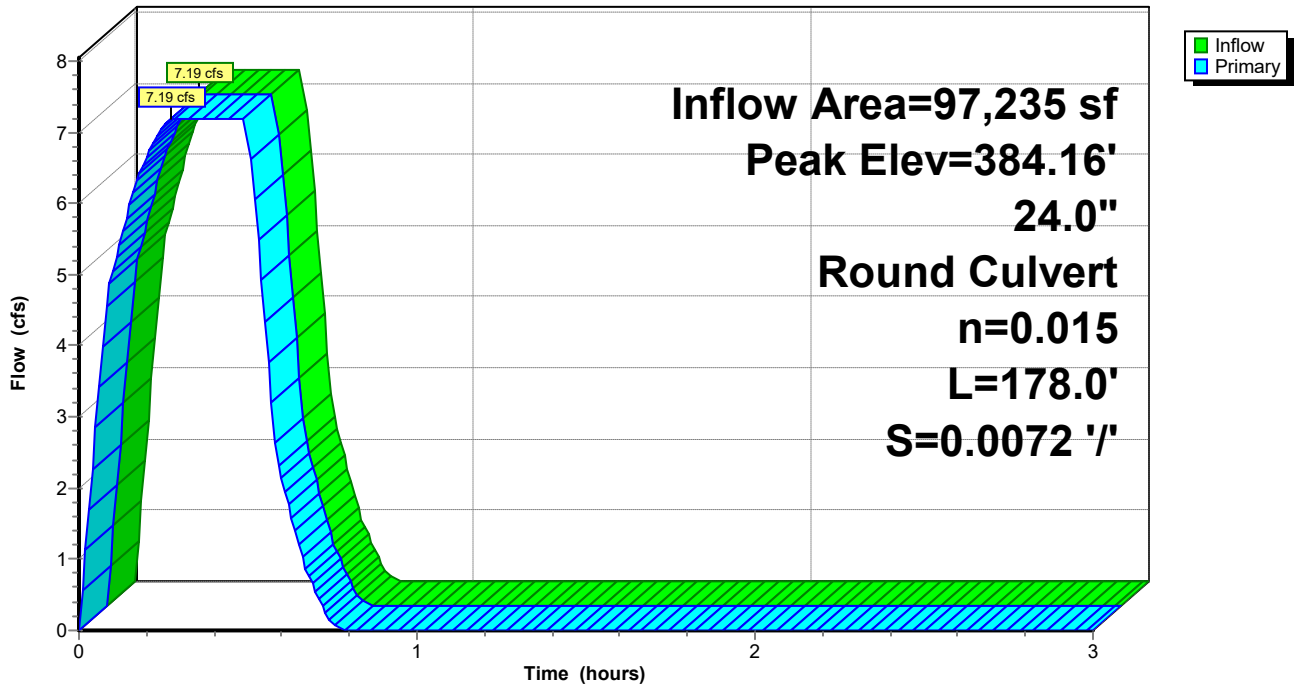

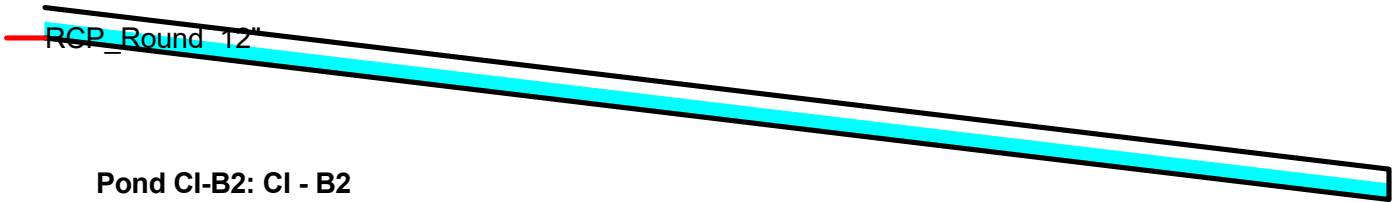

Pond CI-B2: CI - B2

Pond CI-B2: CI - B2

Hydrograph

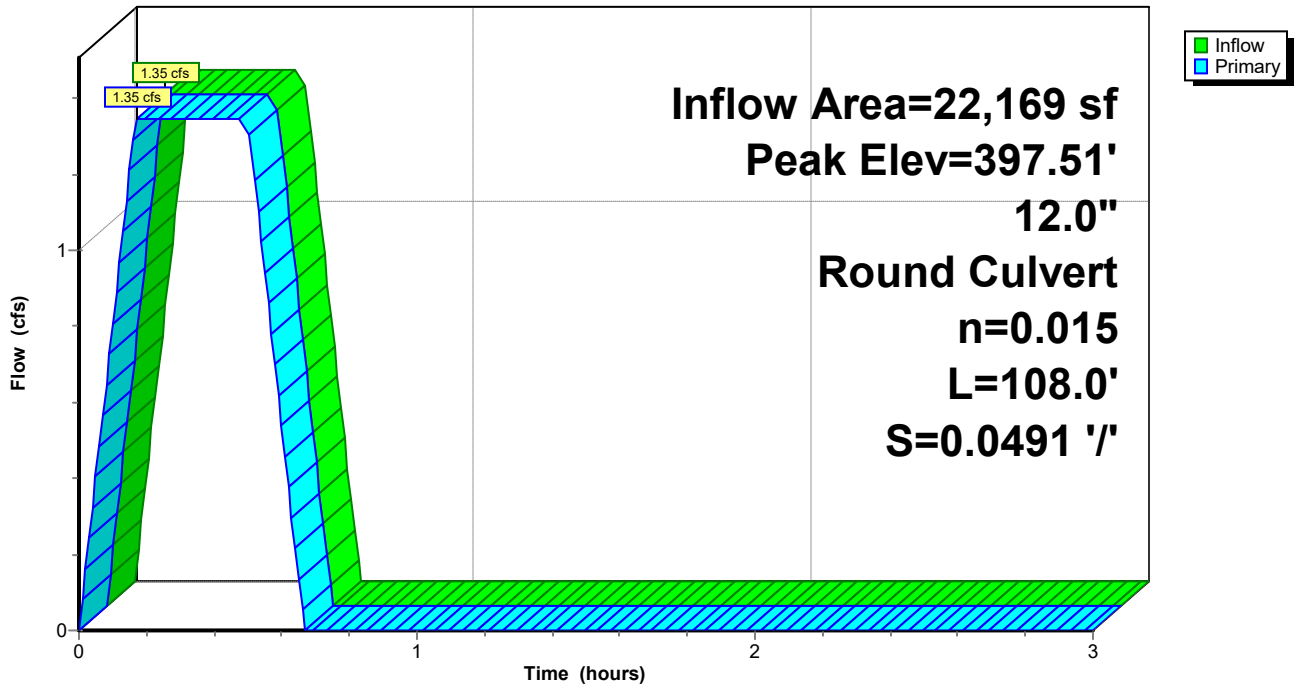

RCP Round 18"
Pond JB-A2: JB - A2

Pond JB-A2: JB - A2

Hydrograph

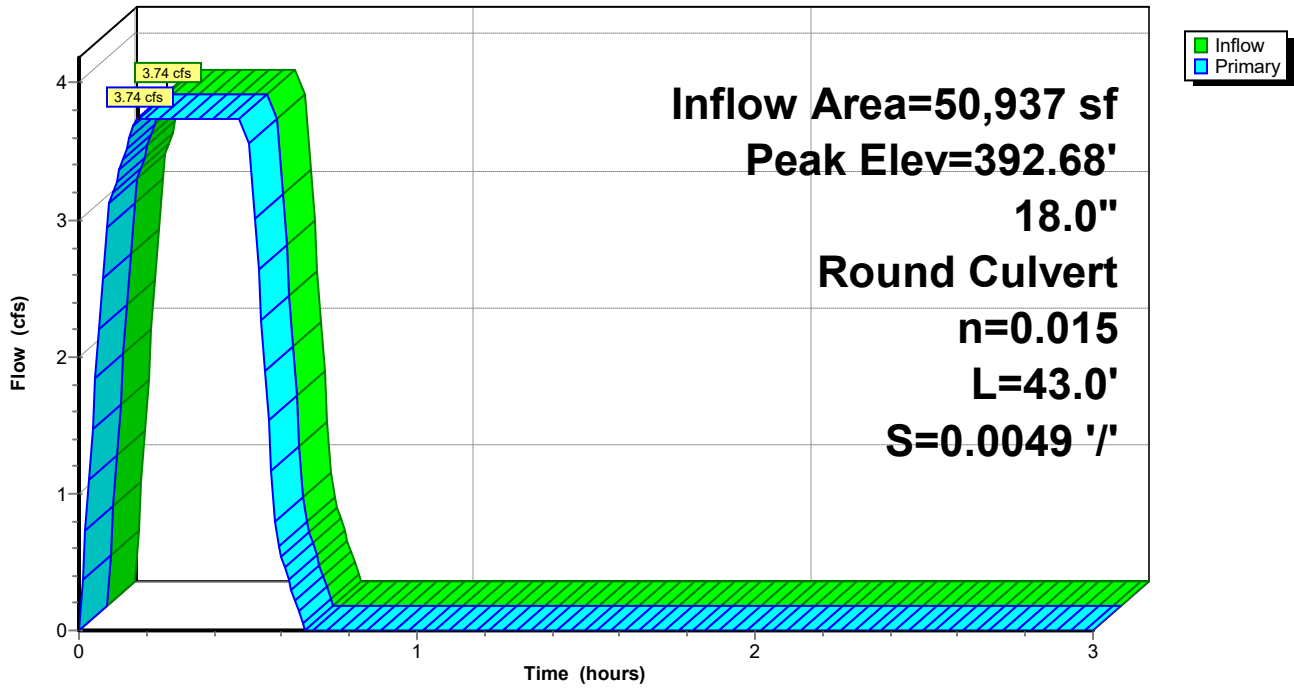

Channel Report

Pipe-A1

Circular

Diameter (ft) = 1.50

Invert Elev (ft) = 392.62

Slope (%) = 0.50

N-Value = 0.015

Calculations

Compute by: Known Q

Known Q (cfs) = 1.78

Highlighted

Depth (ft) = 0.54

Q (cfs) = 1.780

Area (sqft) = 0.58

Velocity (ft/s) = 3.09

Wetted Perim (ft) = 1.93

Crit Depth, Y_c (ft) = 0.50

Top Width (ft) = 1.44

EGL (ft) = 0.69

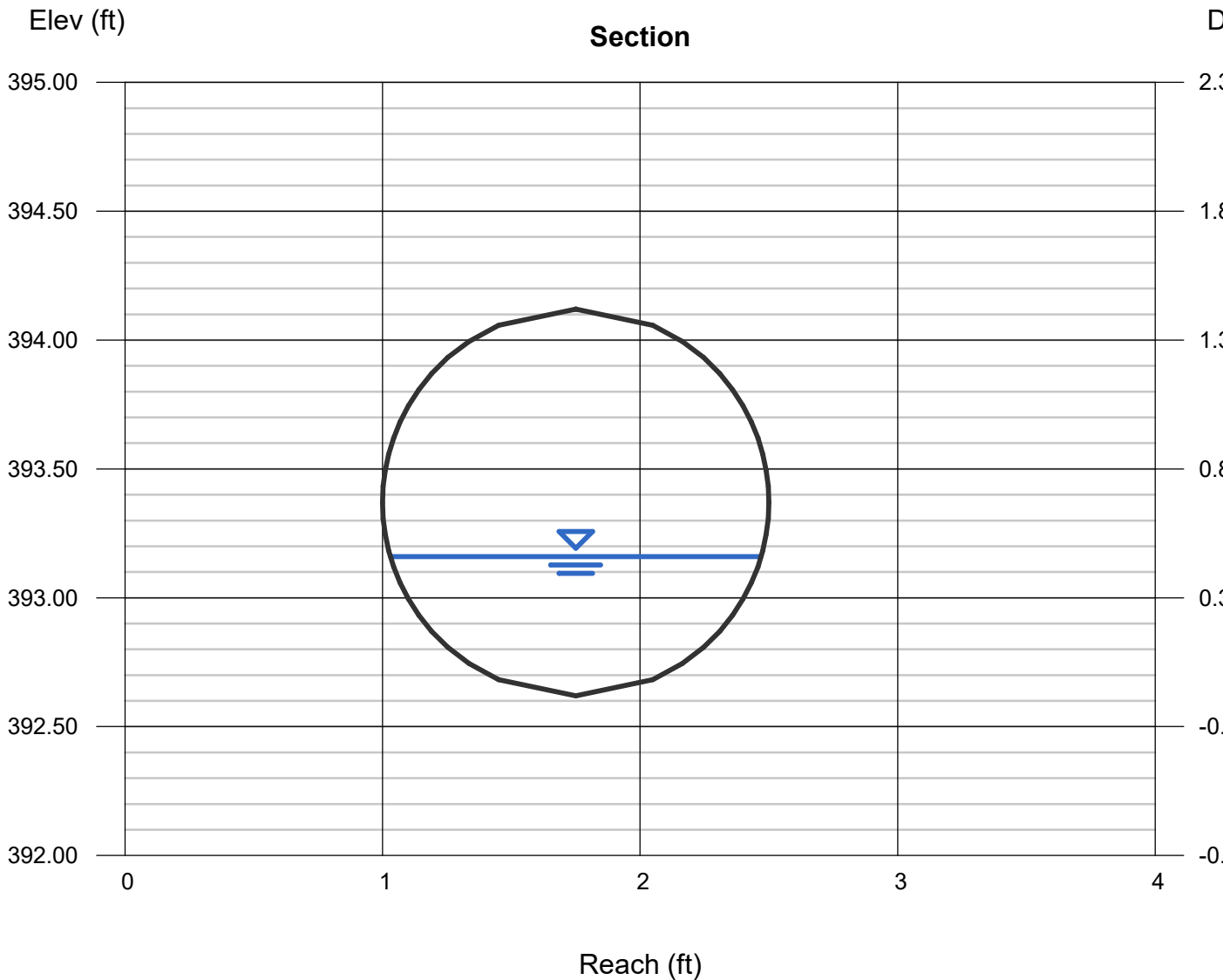

Channel Report

Pipe-A2

Circular

Diameter (ft) = 1.50

Invert Elev (ft) = 391.60

Slope (%) = 0.50

N-Value = 0.015

Calculations

Compute by: Known Q

Known Q (cfs) = 4.35

Highlighted

Depth (ft) = 0.91

Q (cfs) = 4.350

Area (sqft) = 1.13

Velocity (ft/s) = 3.86

Wetted Perim (ft) = 2.68

Crit Depth, Yc (ft) = 0.80

Top Width (ft) = 1.46

EGL (ft) = 1.14

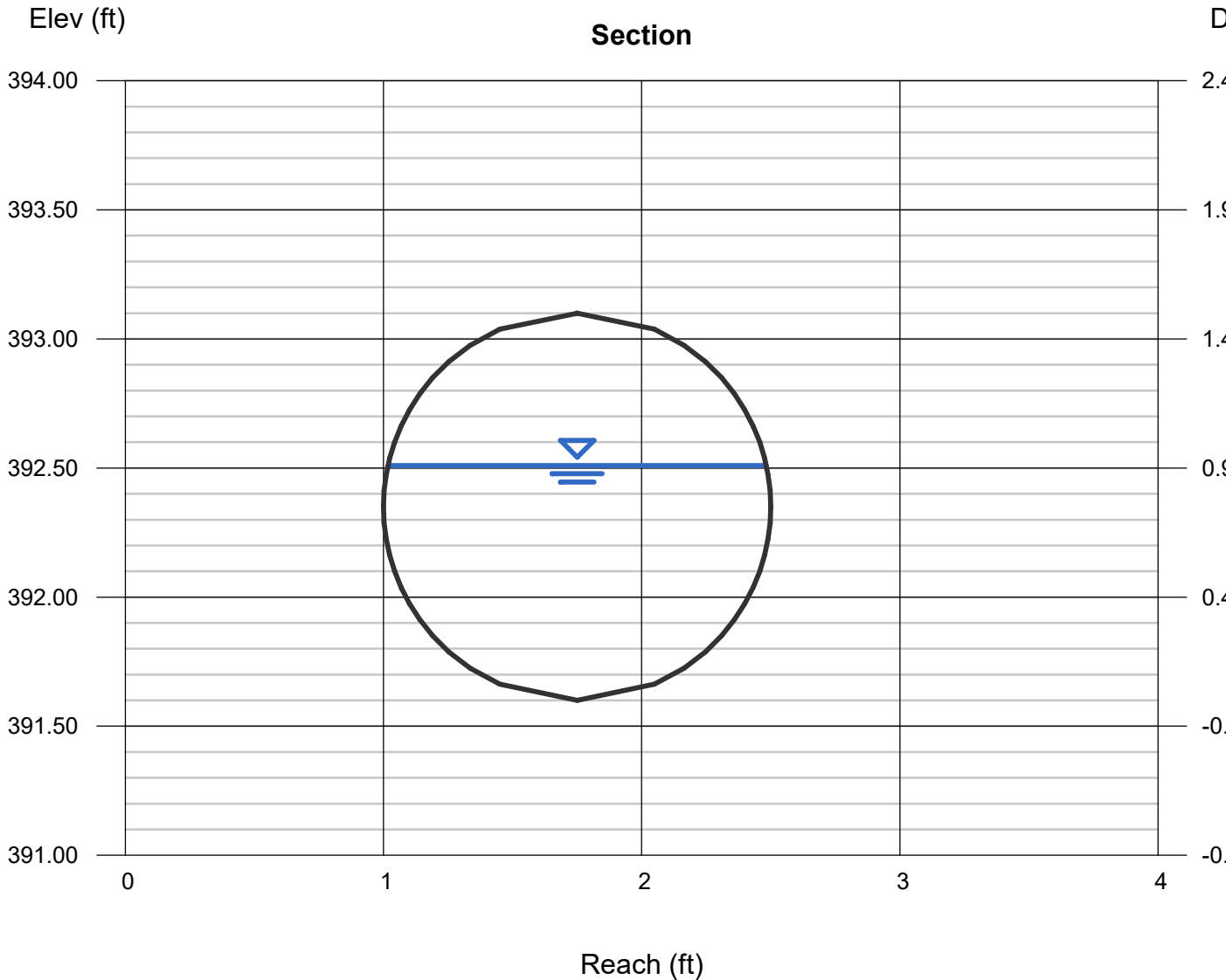

Channel Report

Pipe-A3

Circular

Diameter (ft) = 1.50

Invert Elev (ft) = 391.29

Slope (%) = 6.20

N-Value = 0.015

Calculations

Compute by: Known Q

Known Q (cfs) = 4.55

Highlighted

Depth (ft) = 0.46

Q (cfs) = 4.550

Area (sqft) = 0.46

Velocity (ft/s) = 9.87

Wetted Perim (ft) = 1.76

Crit Depth, Y_c (ft) = 0.82

Top Width (ft) = 1.38

EGL (ft) = 1.98

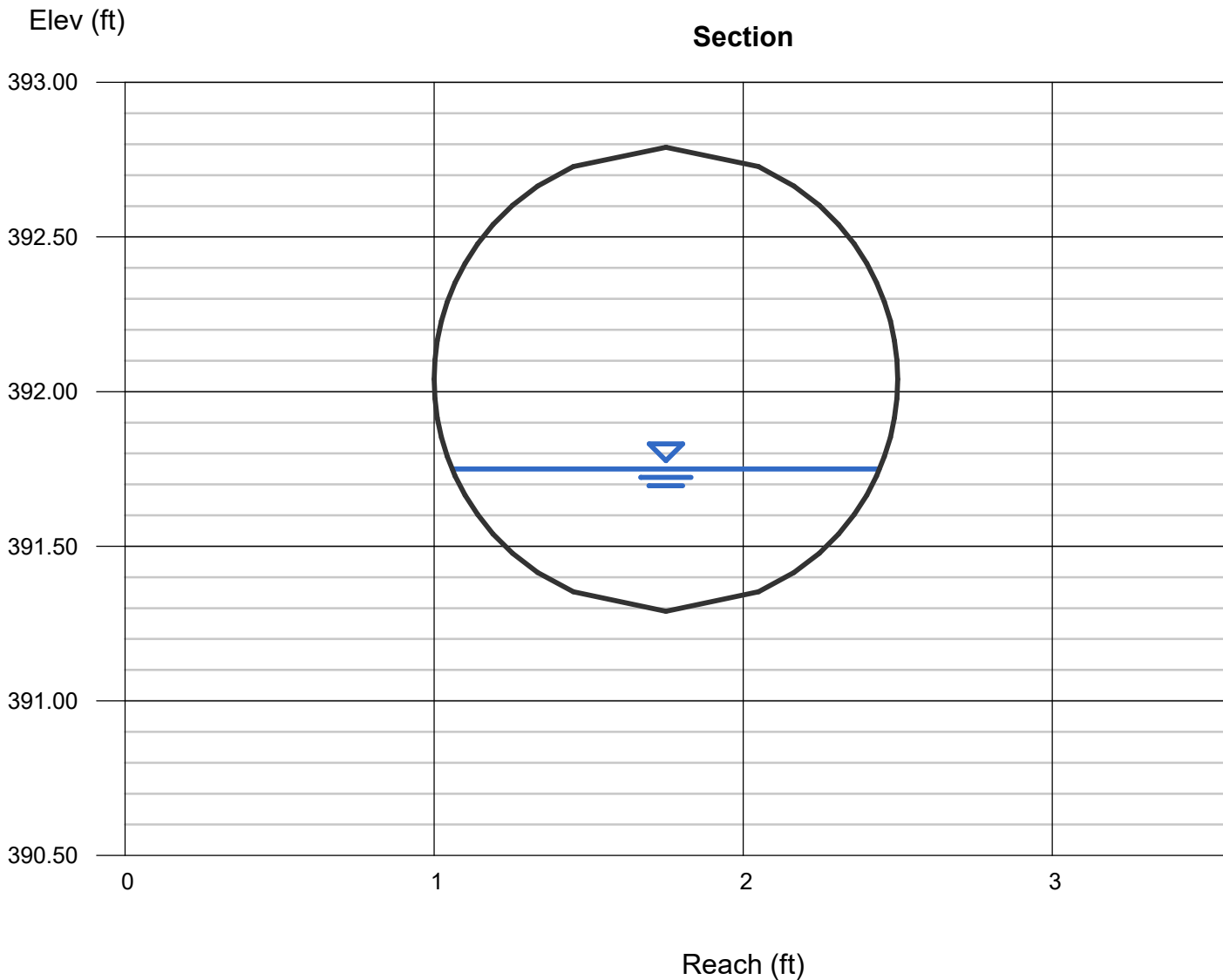

Channel Report

Pipe-A4 (25 yr)

Circular

Diameter (ft) = 1.50

Invert Elev (ft) = 384.34
Slope (%) = 4.85
N-Value = 0.015

Highlighted

Depth (ft) = 0.59
Q (cfs) = 6.510
Area (sqft) = 0.65
Velocity (ft/s) = 10.02
Wetted Perim (ft) = 2.04
Crit Depth, Yc (ft) = 0.99
Top Width (ft) = 1.47
EGL (ft) = 2.15

Calculations

Compute by: Known Q
Known Q (cfs) = 6.51

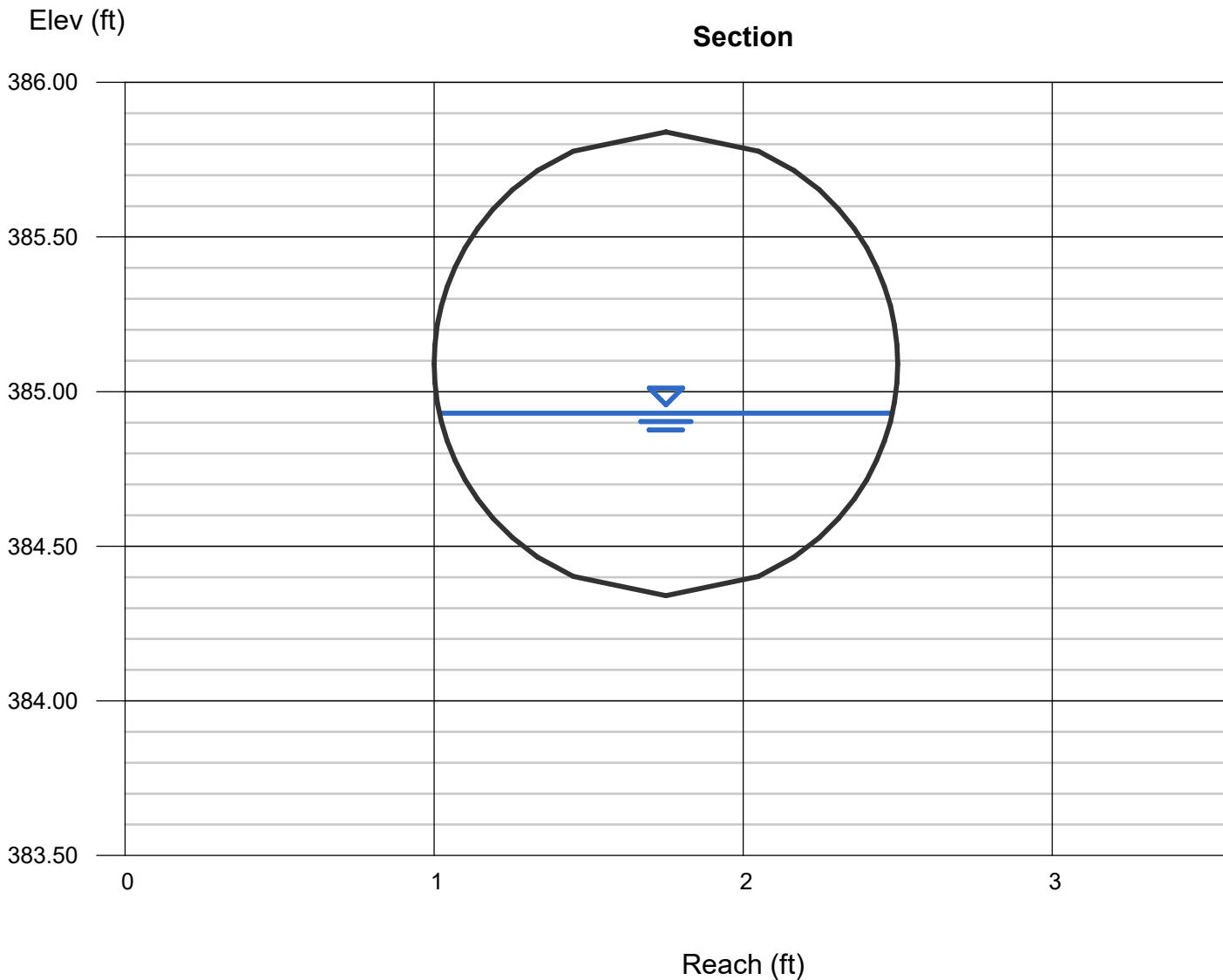

Channel Report

Hydraflow Express Extension for Autodesk® Civil 3D® by Autodesk, Inc.

Wednesday, Mar 25 2026

Pipe-A5 (25 yr)

Circular Diameter (ft) = 2.00
Invert Elev (ft) = 382.91
Slope (%) = 0.72
N-Value

Highlighted

Depth (ft) = 1.01
Q (cfs) = 8.480
Area (sqft) = 1.60
Velocity (ft/s) = 5.30
Wetted Perim (ft) = 3.17
Crit Depth, Yc (ft) = 1.04
Top Width (ft) = 2.00
EGL (ft) = 1.45

Calculations
Compute by: Known Q
Known Q (cfs) = 8.48

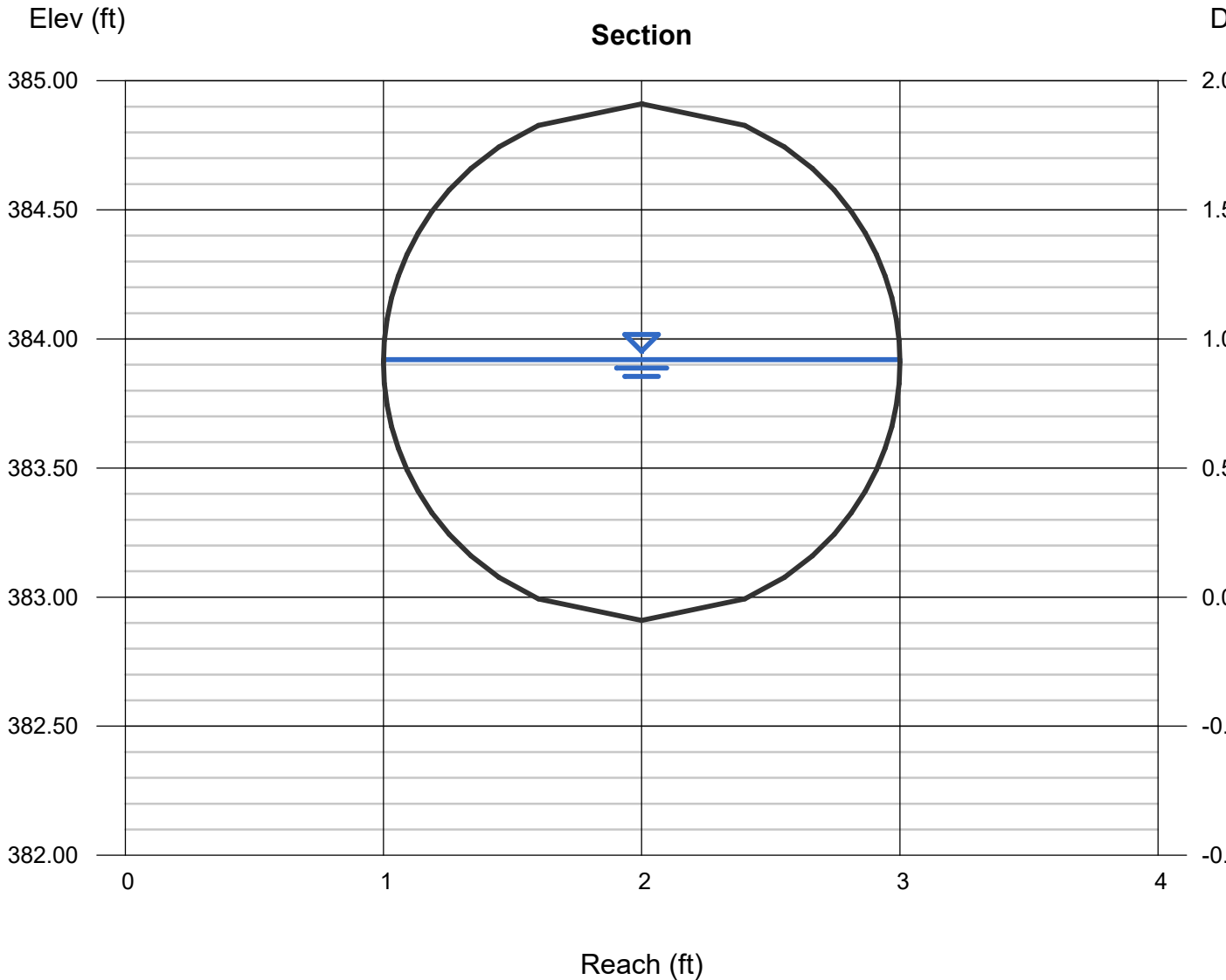

Channel Report

Pipe-B1

Circular

Diameter (ft) = 1.00

Invert Elev (ft) = 397.00

Slope (%) = 4.92

N-Value = 0.015

Calculations

Compute by: Known Q

Known Q (cfs) = 1.57

Highlighted

Depth (ft) = 0.33

Q (cfs) = 1.570

Area (sqft) = 0.23

Velocity (ft/s) = 6.93

Wetted Perim (ft) = 1.22

Crit Depth, Yc (ft) = 0.53

Top Width (ft) = 0.94

EGL (ft) = 1.08

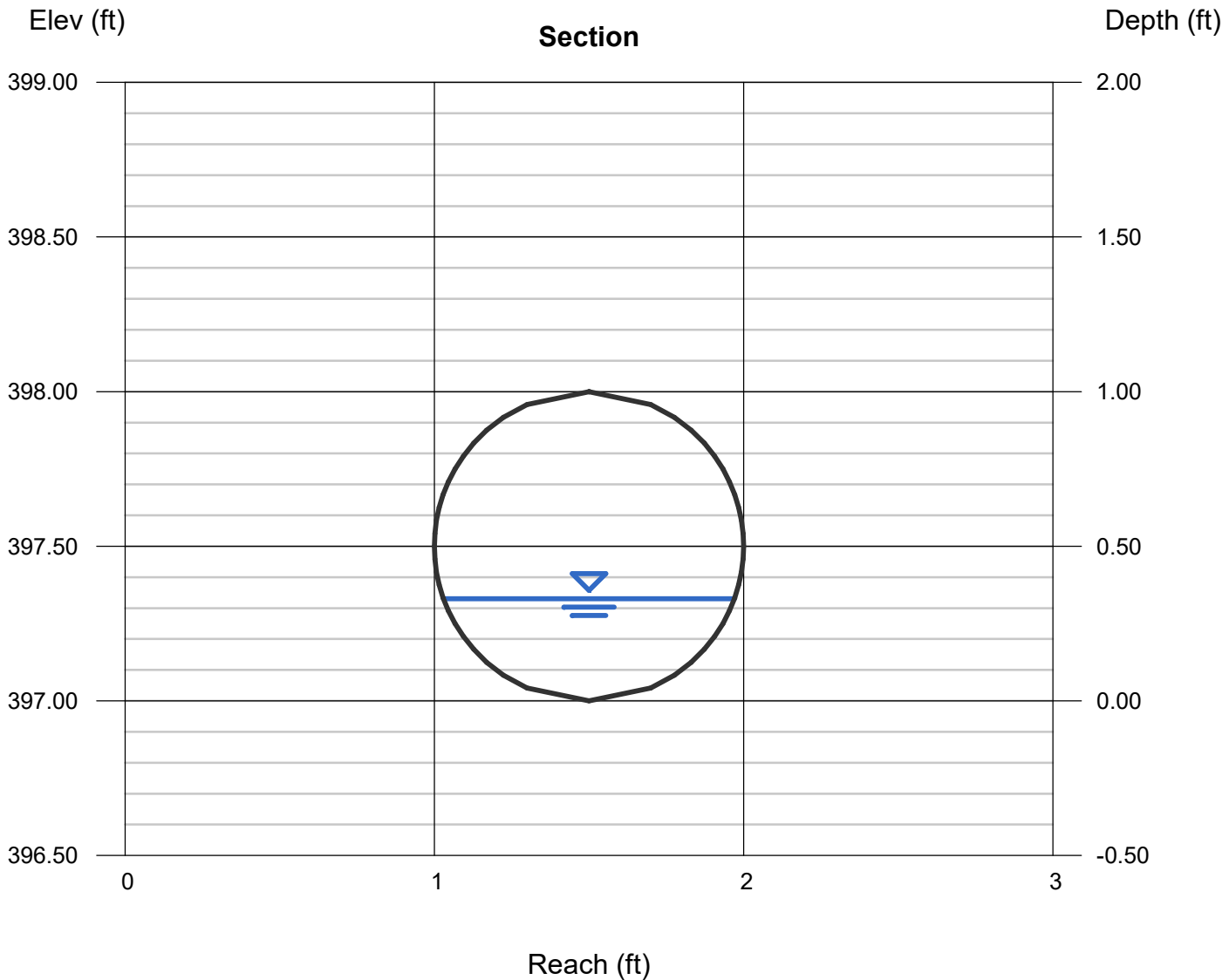

Inlet Report

C-9 Discharge Inlet (25 yr)

Curb Inlet

Location	= On grade
Curb Length (ft)	= 4.00
Throat Height (in)	= 6.00
Grate Area (sqft)	= -0-
Grate Width (ft)	= -0-
Grate Length (ft)	= -0-

Gutter

Slope, Sw (ft/ft)	= 0.083
Slope, Sx (ft/ft)	= 0.020
Local Depr (in)	= 2.00
Gutter Width (ft)	= 1.50
Gutter Slope (%)	= 5.20
Gutter n-value	= 0.016

Calculations

Compute by:	Known Q
Q (cfs)	= 1.19

Highlighted

Q Total (cfs)	= 1.19
Q Capt (cfs)	= 0.75
Q Bypass (cfs)	= 0.44
Depth at Inlet (in)	= 4.19
Efficiency (%)	= 63
Gutter Spread (ft)	= 4.42
Gutter Vel (ft/s)	= 4.47
Bypass Spread (ft)	= 1.90
Bypass Depth (in)	= 1.59

All dimensions in feet

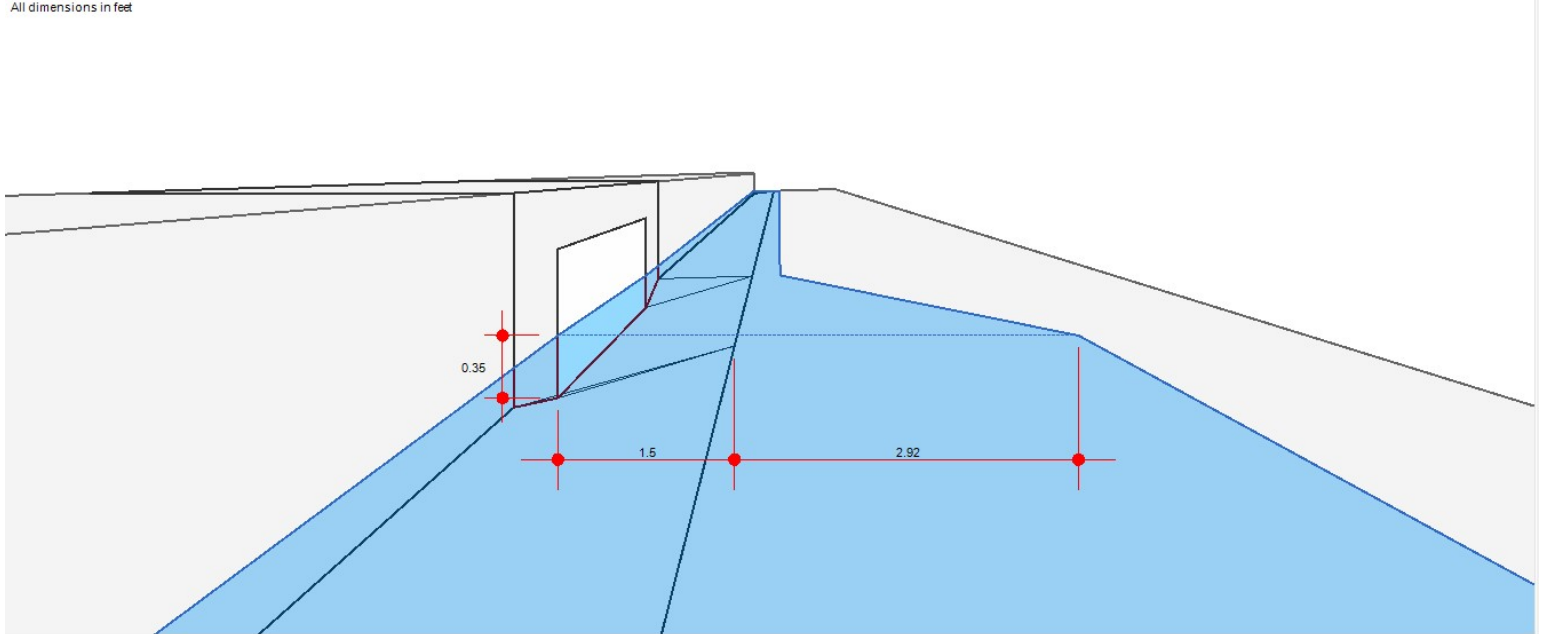

Inlet Report

C-14 Discharge Inlet (25 yr)

Curb Inlet

Location	= On grade
Curb Length (ft)	= 8.00
Throat Height (in)	= 6.00
Grate Area (sqft)	= -0-
Grate Width (ft)	= -0-
Grate Length (ft)	= -0-

Gutter

Slope, Sw (ft/ft)	= 0.083
Slope, Sx (ft/ft)	= 0.020
Local Depr (in)	= 2.00
Gutter Width (ft)	= 1.50
Gutter Slope (%)	= 6.90
Gutter n-value	= 0.016

Calculations

Compute by:	Known Q
Q (cfs)	= 2.41

Highlighted

Q Total (cfs)	= 2.41
Q Capt (cfs)	= 1.78
Q Bypass (cfs)	= 0.63
Depth at Inlet (in)	= 4.58
Efficiency (%)	= 74
Gutter Spread (ft)	= 6.03
Gutter Vel (ft/s)	= 5.55
Bypass Spread (ft)	= 2.42
Bypass Depth (in)	= 1.71

All dimensions in feet

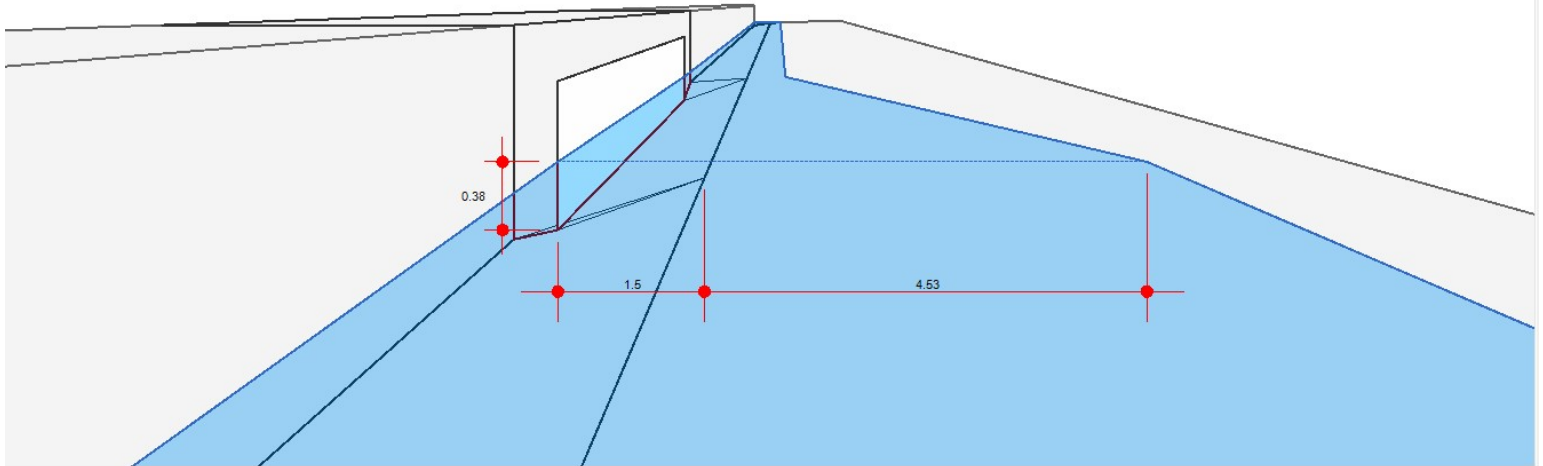

Inlet Report

JB-A1 (100 yr)

Curb Inlet

Location	= Sag
Curb Length (ft)	= 4.00
Throat Height (in)	= 6.00
Grate Area (sqft)	= -0-
Grate Width (ft)	= -0-
Grate Length (ft)	= -0-

Gutter

Slope, Sw (ft/ft)	= 0.033
Slope, Sx (ft/ft)	= 0.060
Local Depr (in)	= -0-
Gutter Width (ft)	= 1.50
Gutter Slope (%)	= -0-
Gutter n-value	= -0-

Calculations

Compute by:	Known Q
Q (cfs)	= 1.78

Highlighted

Q Total (cfs)	= 1.78
Q Capt (cfs)	= 1.78
Q Bypass (cfs)	= -0-
Depth at Inlet (in)	= 3.36
Efficiency (%)	= 100
Gutter Spread (ft)	= 5.34
Gutter Vel (ft/s)	= -0-
Bypass Spread (ft)	= -0-
Bypass Depth (in)	= -0-

All dimensions in feet

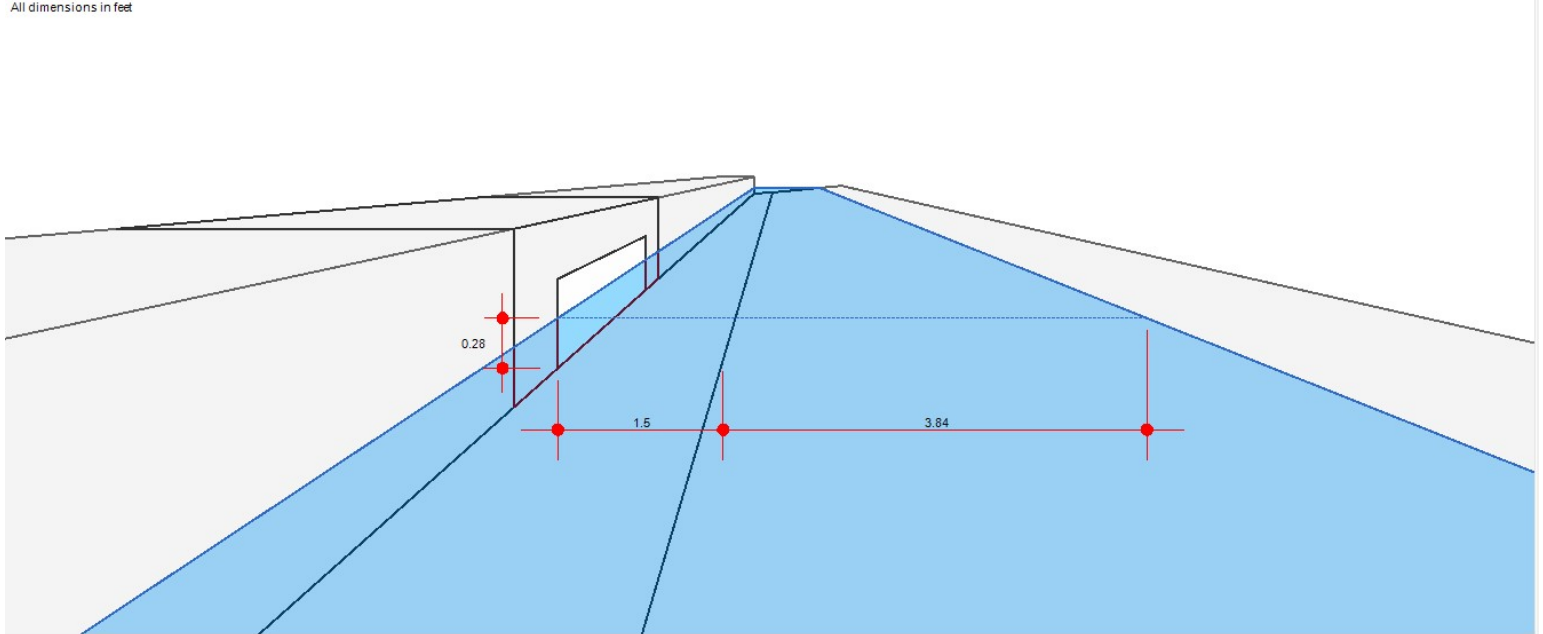

Inlet Report

JB-A3 (100 yr)

Curb Inlet

Location	= Sag
Curb Length (ft)	= 4.00
Throat Height (in)	= 6.00
Grate Area (sqft)	= -0-
Grate Width (ft)	= -0-
Grate Length (ft)	= -0-

Gutter

Slope, Sw (ft/ft)	= 0.033
Slope, Sx (ft/ft)	= 0.060
Local Depr (in)	= -0-
Gutter Width (ft)	= 1.50
Gutter Slope (%)	= -0-
Gutter n-value	= -0-

Calculations

Compute by:	Known Q
Q (cfs)	= 0.20

Highlighted

Q Total (cfs)	= 0.20
Q Capt (cfs)	= 0.20
Q Bypass (cfs)	= -0-
Depth at Inlet (in)	= 0.78
Efficiency (%)	= 100
Gutter Spread (ft)	= 1.76
Gutter Vel (ft/s)	= -0-
Bypass Spread (ft)	= -0-
Bypass Depth (in)	= -0-

All dimensions in feet

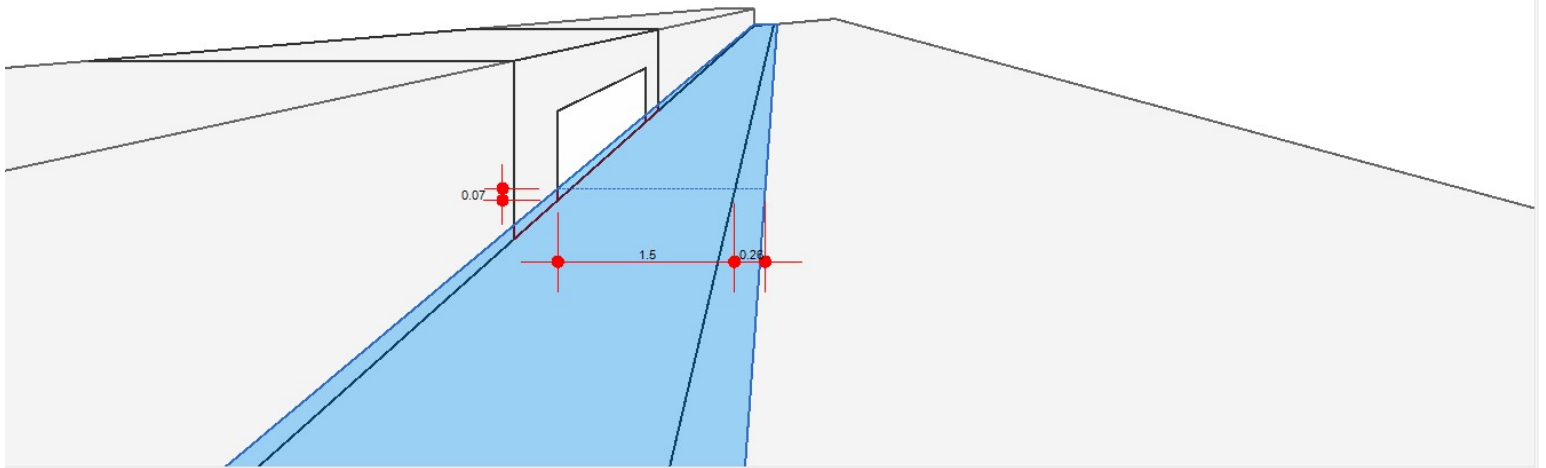

Inlet Report

JB-B1 (100 yr)

Curb Inlet

Location	= Sag
Curb Length (ft)	= 6.00
Throat Height (in)	= 6.00
Grate Area (sqft)	= -0-
Grate Width (ft)	= -0-
Grate Length (ft)	= -0-

Gutter

Slope, Sw (ft/ft)	= 0.033
Slope, Sx (ft/ft)	= 0.020
Local Depr (in)	= -0-
Gutter Width (ft)	= 1.50
Gutter Slope (%)	= -0-
Gutter n-value	= -0-

Calculations

Compute by:	Known Q
Q (cfs)	= 1.57

Highlighted

Q Total (cfs)	= 1.57
Q Capt (cfs)	= 1.57
Q Bypass (cfs)	= -0-
Depth at Inlet (in)	= 2.43
Efficiency (%)	= 100
Gutter Spread (ft)	= 9.16
Gutter Vel (ft/s)	= -0-
Bypass Spread (ft)	= -0-
Bypass Depth (in)	= -0-

All dimensions in feet

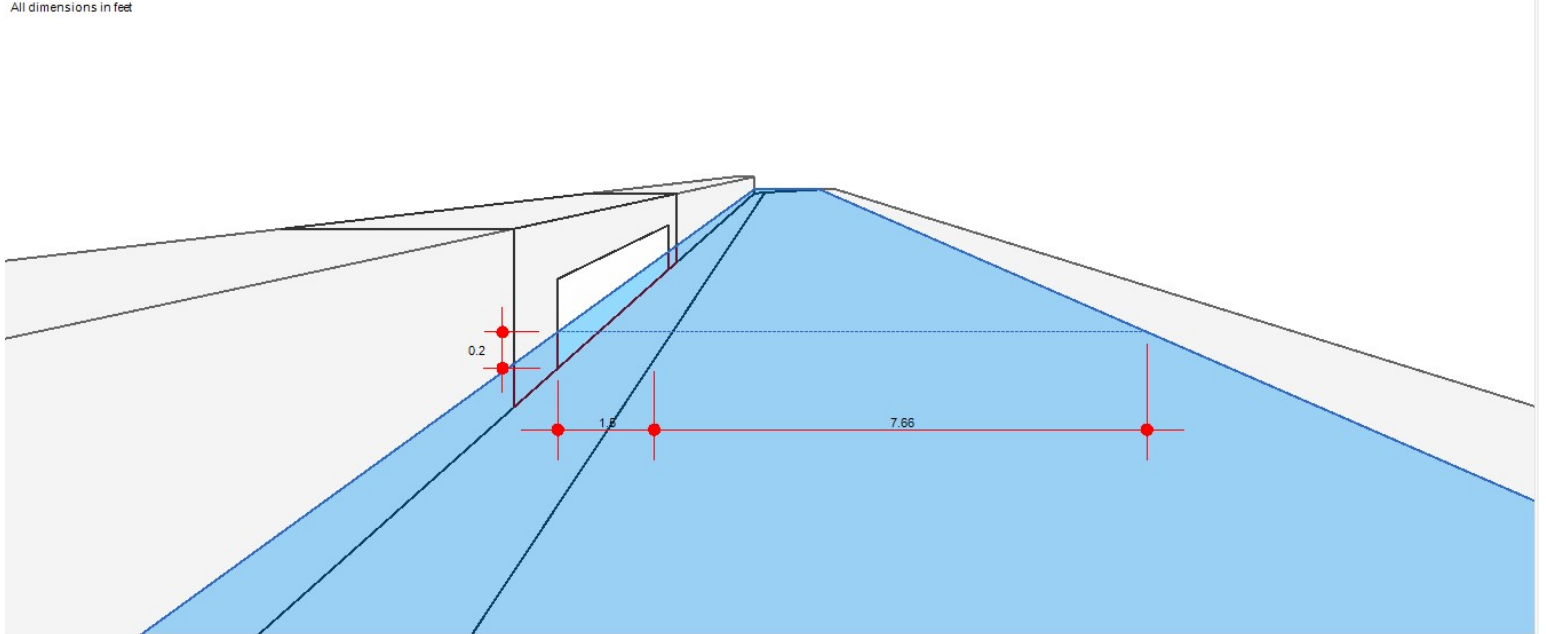

DETENTION BASIN OUTLET STRUCTURES



FEMA FLOOD INSURANCE RATE MAP

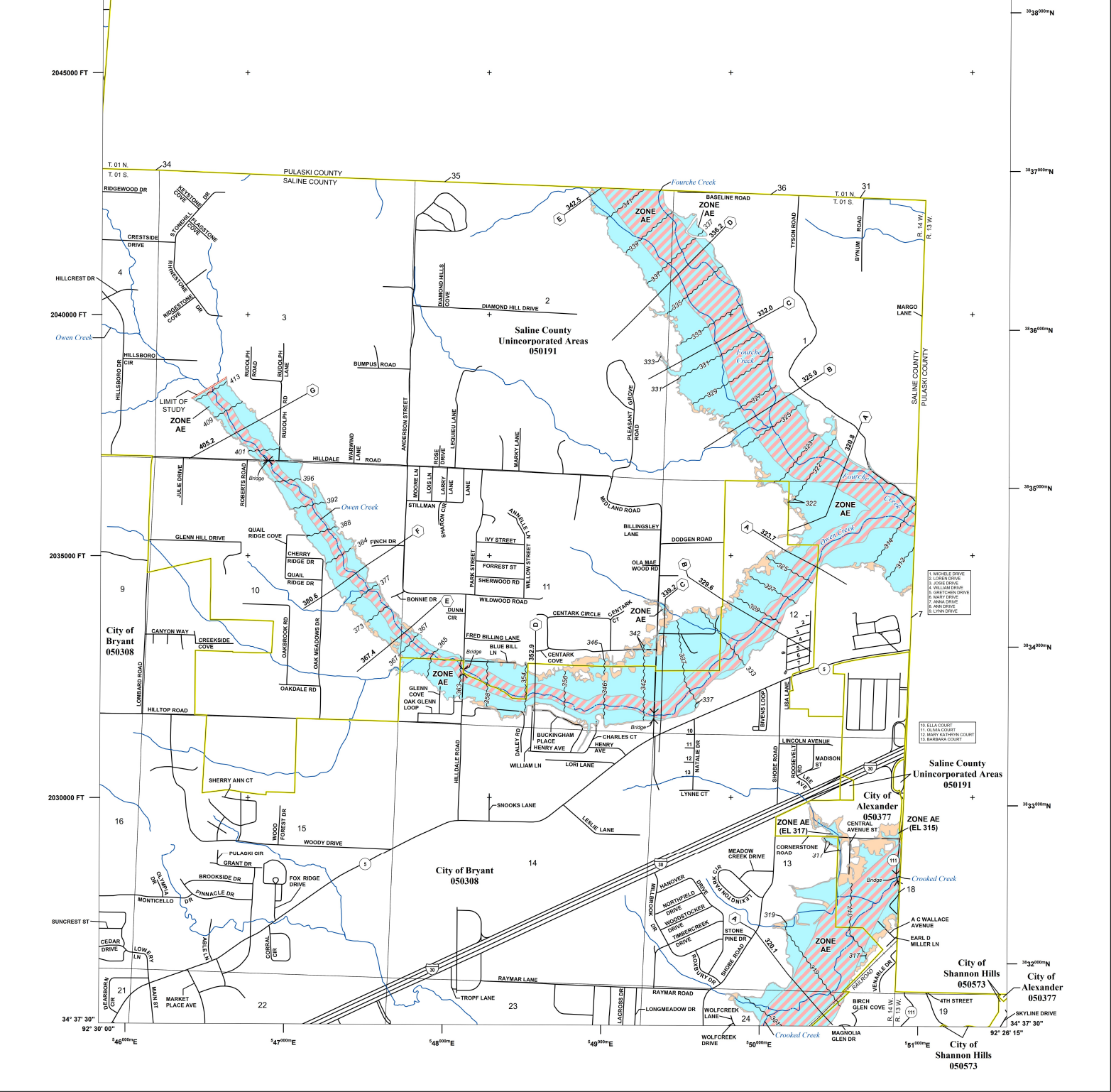

FLOOD HAZARD INFORMATION

SEE FIS REPORT FOR DETAILED LEGEND AND INDEX MAP FOR FIRM PANEL LAYOUT
THE INFORMATION DEPICTED ON THIS MAP AND SUPPORTING
DOCUMENTATION ARE ALSO AVAILABLE IN DIGITAL FORMAT AT
[HTTPS://MSC.FEMA.GOV](https://msc.fema.gov)

	Without Base Flood Elevation (BFE) Zone A, V, A99
	With BFE or Depth Zone AE, AO, AH, VE, AR
	Regulatory Floodway
	0.2% Annual Chance Flood Hazard, Areas of 1% annual chance flood with average depth less than one foot or with drainage areas of less than one square mile Zone X
	Future Conditions 1% Annual Chance Flood Hazard Zone X
	Area with Reduced Flood Risk due to Levee See Notes. Zone X
	Area with Flood Risk due to Levee Zone D
	NO SCREEN Area of Minimal Flood Hazard Zone X
	Area of Undetermined Flood Hazard Zone D
	Channel, Culvert, or Storm Sewer
	Levee, Dike, or Floodwall
	Cross Sections with 1% Annual Chance Water Surface Elevation

NOTES TO USERS

For information and questions about this Flood Insurance Rate Map (FIRM), available products associated with this FIRM, including historic versions, the current map date for each FIRM panel, how to order products, or the National Flood Insurance Program (NFIP) in general, please call the FEMA Map Information Exchange at 1-877-FEMA-MAP (1-877-336-2627) or visit the FEMA Flood Map Service Center website at <https://msc.fema.gov>. Available products may include previously issued Letters of Map Change, a Flood Insurance Study Report, and/or digital versions of this map. Many of these products can be ordered or obtained directly from the website.

Communities assessing land on adjacent FIRM panels must obtain a current copy of the adjacent panel as well as the current FIRM Index. These may be obtained directly from the Map Service Center at the number listed above.

For community and countywide map dates refer to the Flood Insurance Study report for this jurisdiction.

To determine if flood insurance is available in the community, contact your insurance agent or call the National Flood Insurance Program at 1-800-438-8620.

Base map information shown on this FIRM was derived from U.S. Census Bureau TIGER files, dated 2015, and digital data provided by the Arkansas Geographic Information Office, dated 2015.

SCALE

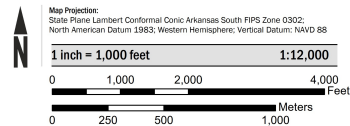

PANEL LOCATOR

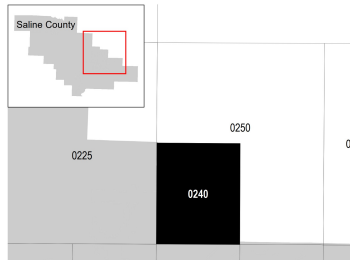

National Flood Insurance Program

NATIONAL FLOOD INSURANCE PROGRAM
FLOOD INSURANCE RATE MAP

SALINE COUNTY, ARKANSAS
and Incorporated Areas

PANEL 240 OF 575

Panel Contains:

COMMUNITY	NUMBER	PANEL	SUFFIX
ALEXANDER, CITY OF	050377	0240	E
BRANT, CITY OF	050308	0240	E
SALINE COUNTY	050191	0240	E
SHANNON HILLS, CITY OF	050573	0240	E



StormTrap[®]

MODULAR CONCRETE
STORMWATER MANAGEMENT

JOB Goddard school

SHEET NO. _____ OF _____ REV. _____

CALCULATED BY _____ DATE _____

CHECKED BY _____ DATE _____

SCALE _____

Universal Soil loss calc Equation: $A = R \cdot K \cdot L \cdot S \cdot C \cdot P$

A = sediment yield; tons per acre per yr

R = Rainfall factor

K = soil erodibility factor

L = slope length factor

S = slope gradient factor

C = Cropping Management Factor

P = erosion control practice factor

Allowable soil loss shall not exceed 5 tons/acre/yr

R in Bryant is 300

K TUC - Tiak silt loam 3-800 factor: 0.32

LS: 5.25 @ 300 ft 0.9885

C: .06 straw or hay tied, anchored

P: Interceptor Dikes 0.50

$$E = (300)(0.32)(0.9885)(1)(1) = 94.896 \text{ tons/Acre/yr w/out erosion control}$$

$$E = (300)(0.32)(0.9885)(.06)(0.50) = 2.85 \text{ tons/Acre/yr w/erosion control}$$

Custom Soil Resource Report for **Saline County, Arkansas**

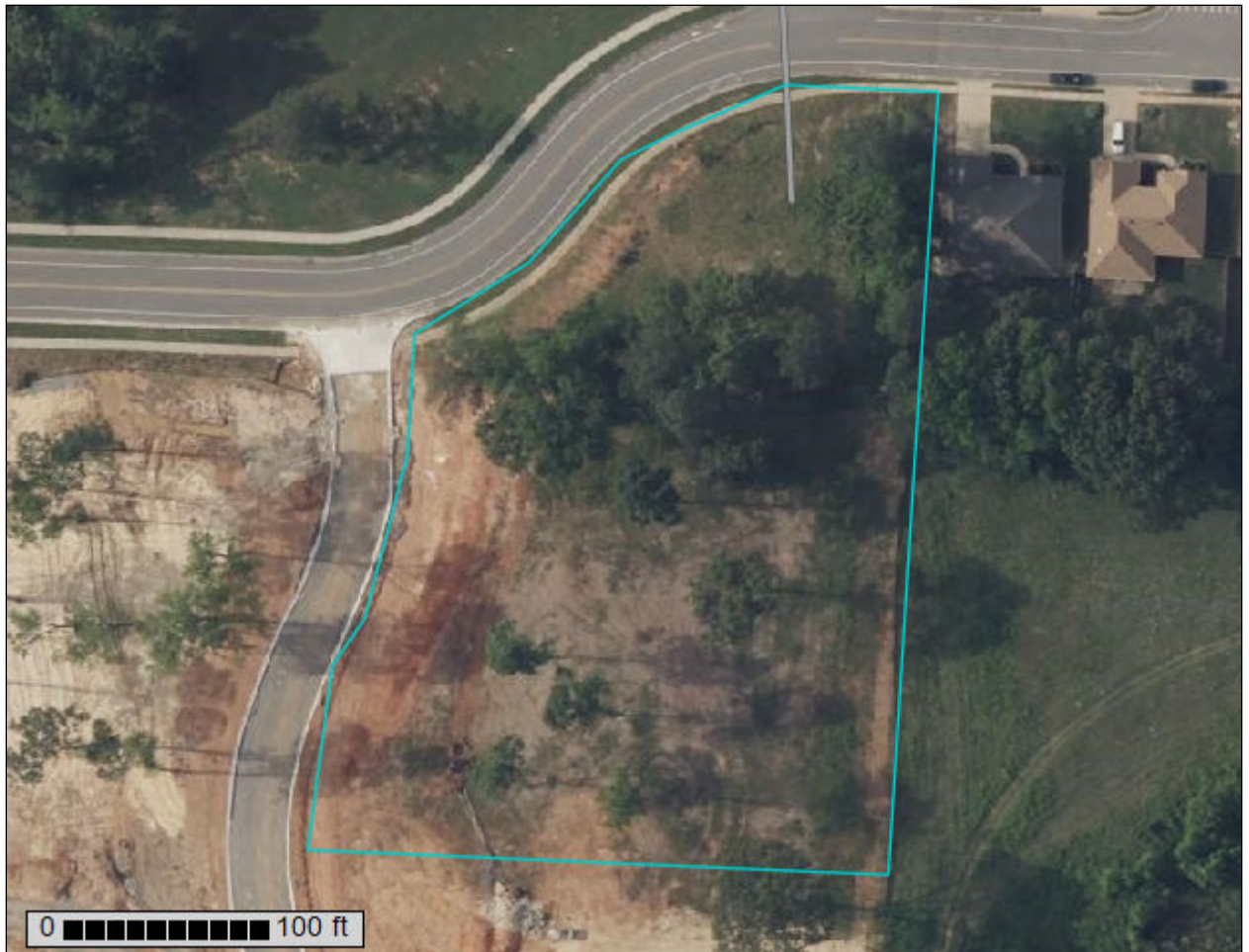

Preface

Soil surveys contain information that affects land use planning in survey areas. They highlight soil limitations that affect various land uses and provide information about the properties of the soils in the survey areas. Soil surveys are designed for many different users, including farmers, ranchers, foresters, agronomists, urban planners, community officials, engineers, developers, builders, and home buyers. Also, conservationists, teachers, students, and specialists in recreation, waste disposal, and pollution control can use the surveys to help them understand, protect, or enhance the environment.

Various land use regulations of Federal, State, and local governments may impose special restrictions on land use or land treatment. Soil surveys identify soil properties that are used in making various land use or land treatment decisions. The information is intended to help the land users identify and reduce the effects of soil limitations on various land uses. The landowner or user is responsible for identifying and complying with existing laws and regulations.

Although soil survey information can be used for general farm, local, and wider area planning, onsite investigation is needed to supplement this information in some cases. Examples include soil quality assessments (<http://www.nrcs.usda.gov/wps/portal/nrcs/main/soils/health/>) and certain conservation and engineering applications. For more detailed information, contact your local USDA Service Center (<https://offices.sc.egov.usda.gov/locator/app?agency=nrcs>) or your NRCS State Soil Scientist (http://www.nrcs.usda.gov/wps/portal/nrcs/detail/soils/contactus/?cid=nrcs142p2_053951).

Great differences in soil properties can occur within short distances. Some soils are seasonally wet or subject to flooding. Some are too unstable to be used as a foundation for buildings or roads. Clayey or wet soils are poorly suited to use as septic tank absorption fields. A high water table makes a soil poorly suited to basements or underground installations.

The National Cooperative Soil Survey is a joint effort of the United States Department of Agriculture and other Federal agencies, State agencies including the Agricultural Experiment Stations, and local agencies. The Natural Resources Conservation Service (NRCS) has leadership for the Federal part of the National Cooperative Soil Survey.

Information about soils is updated periodically. Updated information is available through the NRCS Web Soil Survey, the site for official soil survey information.

The U.S. Department of Agriculture (USDA) prohibits discrimination in all its programs and activities on the basis of race, color, national origin, age, disability, and where applicable, sex, marital status, familial status, parental status, religion, sexual orientation, genetic information, political beliefs, reprisal, or because all or a part of an individual's income is derived from any public assistance program. (Not all prohibited bases apply to all programs.) Persons with disabilities who require

alternative means for communication of program information (Braille, large print, audiotape, etc.) should contact USDA's TARGET Center at (202) 720-2600 (voice and TDD). To file a complaint of discrimination, write to USDA, Director, Office of Civil Rights, 1400 Independence Avenue, S.W., Washington, D.C. 20250-9410 or call (800) 795-3272 (voice) or (202) 720-6382 (TDD). USDA is an equal opportunity provider and employer.

Contents

Preface	2
How Soil Surveys Are Made	5
Soil Map	8
Soil Map.....	9
Legend.....	10
Map Unit Legend.....	11
Map Unit Descriptions.....	11
Saline County, Arkansas.....	13
29—Tiak silt loam, 3 to 8 percent slopes.....	13
References	14

How Soil Surveys Are Made

Soil surveys are made to provide information about the soils and miscellaneous areas in a specific area. They include a description of the soils and miscellaneous areas and their location on the landscape and tables that show soil properties and limitations affecting various uses. Soil scientists observed the steepness, length, and shape of the slopes; the general pattern of drainage; the kinds of crops and native plants; and the kinds of bedrock. They observed and described many soil profiles. A soil profile is the sequence of natural layers, or horizons, in a soil. The profile extends from the surface down into the unconsolidated material in which the soil formed or from the surface down to bedrock. The unconsolidated material is devoid of roots and other living organisms and has not been changed by other biological activity.

Currently, soils are mapped according to the boundaries of major land resource areas (MLRAs). MLRAs are geographically associated land resource units that share common characteristics related to physiography, geology, climate, water resources, soils, biological resources, and land uses (USDA, 2006). Soil survey areas typically consist of parts of one or more MLRA.

The soils and miscellaneous areas in a survey area occur in an orderly pattern that is related to the geology, landforms, relief, climate, and natural vegetation of the area. Each kind of soil and miscellaneous area is associated with a particular kind of landform or with a segment of the landform. By observing the soils and miscellaneous areas in the survey area and relating their position to specific segments of the landform, a soil scientist develops a concept, or model, of how they were formed. Thus, during mapping, this model enables the soil scientist to predict with a considerable degree of accuracy the kind of soil or miscellaneous area at a specific location on the landscape.

Commonly, individual soils on the landscape merge into one another as their characteristics gradually change. To construct an accurate soil map, however, soil scientists must determine the boundaries between the soils. They can observe only a limited number of soil profiles. Nevertheless, these observations, supplemented by an understanding of the soil-vegetation-landscape relationship, are sufficient to verify predictions of the kinds of soil in an area and to determine the boundaries.

Soil scientists recorded the characteristics of the soil profiles that they studied. They noted soil color, texture, size and shape of soil aggregates, kind and amount of rock fragments, distribution of plant roots, reaction, and other features that enable them to identify soils. After describing the soils in the survey area and determining their properties, the soil scientists assigned the soils to taxonomic classes (units). Taxonomic classes are concepts. Each taxonomic class has a set of soil characteristics with precisely defined limits. The classes are used as a basis for comparison to classify soils systematically. Soil taxonomy, the system of taxonomic classification used in the United States, is based mainly on the kind and character of soil properties and the arrangement of horizons within the profile. After the soil

Custom Soil Resource Report

scientists classified and named the soils in the survey area, they compared the individual soils with similar soils in the same taxonomic class in other areas so that they could confirm data and assemble additional data based on experience and research.

The objective of soil mapping is not to delineate pure map unit components; the objective is to separate the landscape into landforms or landform segments that have similar use and management requirements. Each map unit is defined by a unique combination of soil components and/or miscellaneous areas in predictable proportions. Some components may be highly contrasting to the other components of the map unit. The presence of minor components in a map unit in no way diminishes the usefulness or accuracy of the data. The delineation of such landforms and landform segments on the map provides sufficient information for the development of resource plans. If intensive use of small areas is planned, onsite investigation is needed to define and locate the soils and miscellaneous areas.

Soil scientists make many field observations in the process of producing a soil map. The frequency of observation is dependent upon several factors, including scale of mapping, intensity of mapping, design of map units, complexity of the landscape, and experience of the soil scientist. Observations are made to test and refine the soil-landscape model and predictions and to verify the classification of the soils at specific locations. Once the soil-landscape model is refined, a significantly smaller number of measurements of individual soil properties are made and recorded. These measurements may include field measurements, such as those for color, depth to bedrock, and texture, and laboratory measurements, such as those for content of sand, silt, clay, salt, and other components. Properties of each soil typically vary from one point to another across the landscape.

Observations for map unit components are aggregated to develop ranges of characteristics for the components. The aggregated values are presented. Direct measurements do not exist for every property presented for every map unit component. Values for some properties are estimated from combinations of other properties.

While a soil survey is in progress, samples of some of the soils in the area generally are collected for laboratory analyses and for engineering tests. Soil scientists interpret the data from these analyses and tests as well as the field-observed characteristics and the soil properties to determine the expected behavior of the soils under different uses. Interpretations for all of the soils are field tested through observation of the soils in different uses and under different levels of management. Some interpretations are modified to fit local conditions, and some new interpretations are developed to meet local needs. Data are assembled from other sources, such as research information, production records, and field experience of specialists. For example, data on crop yields under defined levels of management are assembled from farm records and from field or plot experiments on the same kinds of soil.

Predictions about soil behavior are based not only on soil properties but also on such variables as climate and biological activity. Soil conditions are predictable over long periods of time, but they are not predictable from year to year. For example, soil scientists can predict with a fairly high degree of accuracy that a given soil will have a high water table within certain depths in most years, but they cannot predict that a high water table will always be at a specific level in the soil on a specific date.

After soil scientists located and identified the significant natural bodies of soil in the survey area, they drew the boundaries of these bodies on aerial photographs and

Custom Soil Resource Report

identified each as a specific map unit. Aerial photographs show trees, buildings, fields, roads, and rivers, all of which help in locating boundaries accurately.

Soil Map

The soil map section includes the soil map for the defined area of interest, a list of soil map units on the map and extent of each map unit, and cartographic symbols displayed on the map. Also presented are various metadata about data used to produce the map, and a description of each soil map unit.

Custom Soil Resource Report
Soil Map

92° 28' 18" W

92° 28' 14" W

34° 38' 26" N

34° 38' 26" N

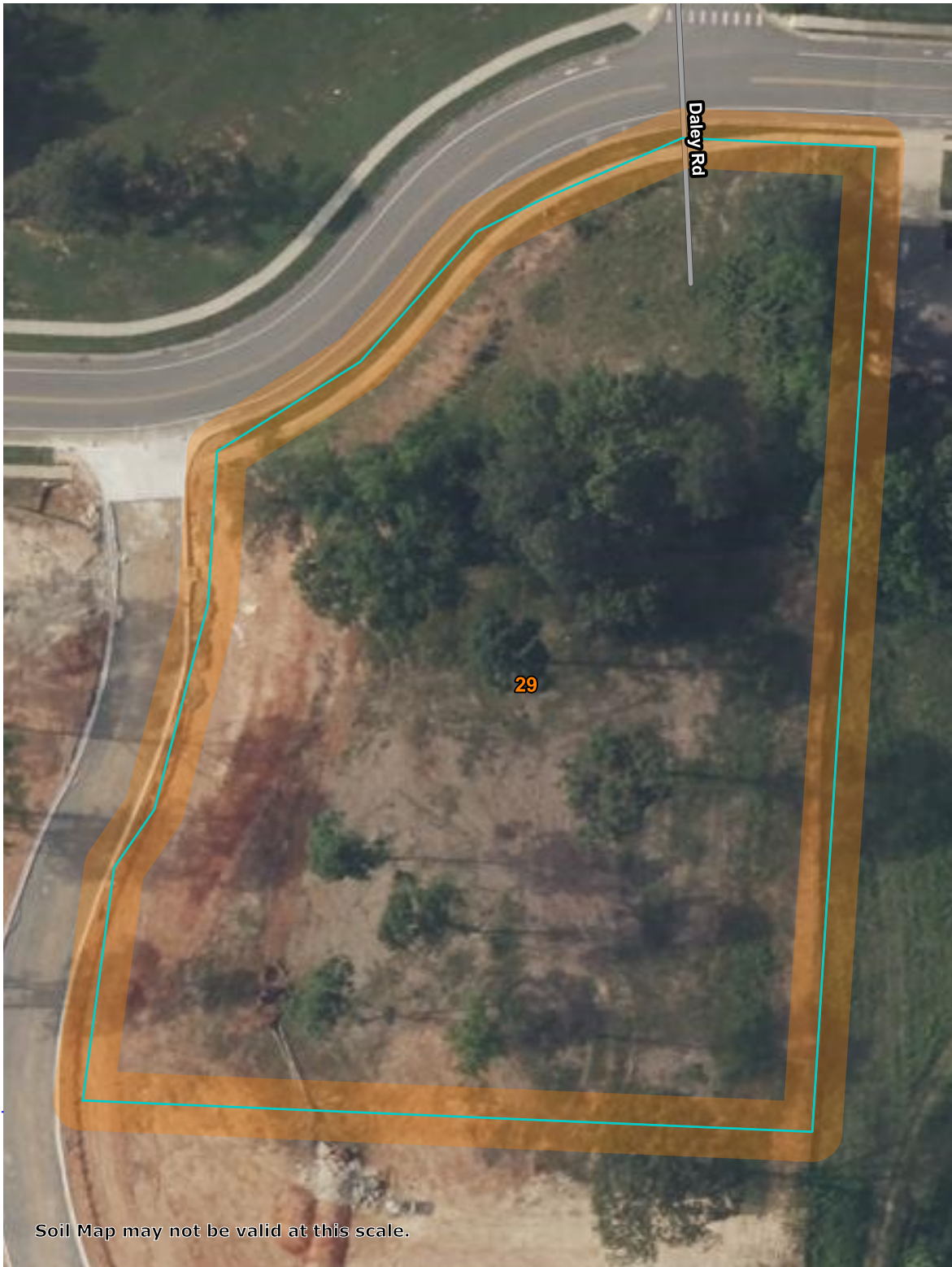

34° 38' 21" N

34° 38' 21" N

92° 28' 18" W

92° 28' 14" W



Map Scale: 1:722 if printed on A portrait (8.5" x 11") sheet.

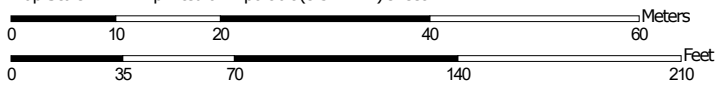

Map projection: Web Mercator Corner coordinates: WGS84

MAP LEGEND

Area of Interest (AOI)

 Area of Interest (AOI)

Soils

 Soil Map Unit Polygons

 Soil Map Unit Lines

 Soil Map Unit Points

Special Point Features

 Blowout

 Borrow Pit

 Clay Spot

 Closed Depression

 Gravel Pit

 Gravelly Spot

 Landfill

 Lava Flow

 Marsh or swamp

 Mine or Quarry

 Miscellaneous Water

 Perennial Water

 Rock Outcrop

 Saline Spot

 Sandy Spot

 Severely Eroded Spot

 Sinkhole

 Slide or Slip

 Sodic Spot

 Spoil Area

 Stony Spot

 Very Stony Spot

 Wet Spot

 Other

 Special Line Features

Water Features

 Streams and Canals

Transportation

 Rails

 Interstate Highways

 US Routes

 Major Roads

 Local Roads

Background

 Aerial Photography

MAP INFORMATION

The soil surveys that comprise your AOI were mapped at 1:20,000.

Warning: Soil Map may not be valid at this scale.

Enlargement of maps beyond the scale of mapping can cause misunderstanding of the detail of mapping and accuracy of soil line placement. The maps do not show the small areas of contrasting soils that could have been shown at a more detailed scale.

Please rely on the bar scale on each map sheet for map measurements.

Source of Map: Natural Resources Conservation Service
 Web Soil Survey URL:
 Coordinate System: Web Mercator (EPSG:3857)

Maps from the Web Soil Survey are based on the Web Mercator projection, which preserves direction and shape but distorts distance and area. A projection that preserves area, such as the Albers equal-area conic projection, should be used if more accurate calculations of distance or area are required.

This product is generated from the USDA-NRCS certified data as of the version date(s) listed below.

Soil Survey Area: Saline County, Arkansas
 Survey Area Data: Version 22, Sep 10, 2025

Soil map units are labeled (as space allows) for map scales 1:50,000 or larger.

Date(s) aerial images were photographed: May 1, 2022—May 29, 2022

The orthophoto or other base map on which the soil lines were compiled and digitized probably differs from the background imagery displayed on these maps. As a result, some minor shifting of map unit boundaries may be evident.

Map Unit Legend

Map Unit Symbol	Map Unit Name	Acres in AOI	Percent of AOI
29	Tiak silt loam, 3 to 8 percent slopes	2.0	100.0%
Totals for Area of Interest		2.0	100.0%

Map Unit Descriptions

The map units delineated on the detailed soil maps in a soil survey represent the soils or miscellaneous areas in the survey area. The map unit descriptions, along with the maps, can be used to determine the composition and properties of a unit.

A map unit delineation on a soil map represents an area dominated by one or more major kinds of soil or miscellaneous areas. A map unit is identified and named according to the taxonomic classification of the dominant soils. Within a taxonomic class there are precisely defined limits for the properties of the soils. On the landscape, however, the soils are natural phenomena, and they have the characteristic variability of all natural phenomena. Thus, the range of some observed properties may extend beyond the limits defined for a taxonomic class. Areas of soils of a single taxonomic class rarely, if ever, can be mapped without including areas of other taxonomic classes. Consequently, every map unit is made up of the soils or miscellaneous areas for which it is named and some minor components that belong to taxonomic classes other than those of the major soils.

Most minor soils have properties similar to those of the dominant soil or soils in the map unit, and thus they do not affect use and management. These are called noncontrasting, or similar, components. They may or may not be mentioned in a particular map unit description. Other minor components, however, have properties and behavioral characteristics divergent enough to affect use or to require different management. These are called contrasting, or dissimilar, components. They generally are in small areas and could not be mapped separately because of the scale used. Some small areas of strongly contrasting soils or miscellaneous areas are identified by a special symbol on the maps. If included in the database for a given area, the contrasting minor components are identified in the map unit descriptions along with some characteristics of each. A few areas of minor components may not have been observed, and consequently they are not mentioned in the descriptions, especially where the pattern was so complex that it was impractical to make enough observations to identify all the soils and miscellaneous areas on the landscape.

The presence of minor components in a map unit in no way diminishes the usefulness or accuracy of the data. The objective of mapping is not to delineate pure taxonomic classes but rather to separate the landscape into landforms or landform segments that have similar use and management requirements. The delineation of such segments on the map provides sufficient information for the development of resource plans. If intensive use of small areas is planned, however, onsite investigation is needed to define and locate the soils and miscellaneous areas.

Custom Soil Resource Report

An identifying symbol precedes the map unit name in the map unit descriptions. Each description includes general facts about the unit and gives important soil properties and qualities.

Soils that have profiles that are almost alike make up a *soil series*. Except for differences in texture of the surface layer, all the soils of a series have major horizons that are similar in composition, thickness, and arrangement.

Soils of one series can differ in texture of the surface layer, slope, stoniness, salinity, degree of erosion, and other characteristics that affect their use. On the basis of such differences, a soil series is divided into *soil phases*. Most of the areas shown on the detailed soil maps are phases of soil series. The name of a soil phase commonly indicates a feature that affects use or management. For example, Alpha silt loam, 0 to 2 percent slopes, is a phase of the Alpha series.

Some map units are made up of two or more major soils or miscellaneous areas. These map units are complexes, associations, or undifferentiated groups.

A *complex* consists of two or more soils or miscellaneous areas in such an intricate pattern or in such small areas that they cannot be shown separately on the maps. The pattern and proportion of the soils or miscellaneous areas are somewhat similar in all areas. Alpha-Beta complex, 0 to 6 percent slopes, is an example.

An *association* is made up of two or more geographically associated soils or miscellaneous areas that are shown as one unit on the maps. Because of present or anticipated uses of the map units in the survey area, it was not considered practical or necessary to map the soils or miscellaneous areas separately. The pattern and relative proportion of the soils or miscellaneous areas are somewhat similar. Alpha-Beta association, 0 to 2 percent slopes, is an example.

An *undifferentiated group* is made up of two or more soils or miscellaneous areas that could be mapped individually but are mapped as one unit because similar interpretations can be made for use and management. The pattern and proportion of the soils or miscellaneous areas in a mapped area are not uniform. An area can be made up of only one of the major soils or miscellaneous areas, or it can be made up of all of them. Alpha and Beta soils, 0 to 2 percent slopes, is an example.

Some surveys include *miscellaneous areas*. Such areas have little or no soil material and support little or no vegetation. Rock outcrop is an example.

Saline County, Arkansas

29—Tiak silt loam, 3 to 8 percent slopes

Map Unit Setting

National map unit symbol: m06q
Landscape: Coastal plains
Elevation: 70 to 570 feet
Mean annual precipitation: 44 to 61 inches
Mean annual air temperature: 49 to 74 degrees F
Frost-free period: 185 to 230 days
Farmland classification: Not prime farmland

Map Unit Composition

Tiak and similar soils: 100 percent
Estimates are based on observations, descriptions, and transects of the mapunit.

Description of Tiak

Setting

Landscape: Coastal plains
Landform: Interfluves
Down-slope shape: Convex
Across-slope shape: Linear
Parent material: Loamy and clayey marine deposits

Typical profile

A - 0 to 7 inches: silt loam
E - 7 to 9 inches: loam
Bt1 - 9 to 32 inches: clay
Bt2 - 32 to 72 inches: clay

Properties and qualities

Slope: 3 to 8 percent
Depth to restrictive feature: More than 80 inches
Drainage class: Moderately well drained
Runoff class: Very high
Capacity of the most limiting layer to transmit water (Ksat): Moderately low to moderately high (0.06 to 0.20 in/hr)
Depth to water table: About 12 to 24 inches
Frequency of flooding: None
Frequency of ponding: None
Available water supply, 0 to 60 inches: High (about 9.3 inches)

Interpretive groups

Land capability classification (irrigated): None specified
Land capability classification (nonirrigated): 3e
Hydrologic Soil Group: C/D
Ecological site: F133BY002TX - Seasonally Wet Upland
Hydric soil rating: No

References

- American Association of State Highway and Transportation Officials (AASHTO). 2004. Standard specifications for transportation materials and methods of sampling and testing. 24th edition.
- American Society for Testing and Materials (ASTM). 2005. Standard classification of soils for engineering purposes. ASTM Standard D2487-00.
- Cowardin, L.M., V. Carter, F.C. Golet, and E.T. LaRoe. 1979. Classification of wetlands and deep-water habitats of the United States. U.S. Fish and Wildlife Service FWS/OBS-79/31.
- Federal Register. July 13, 1994. Changes in hydric soils of the United States.
- Federal Register. September 18, 2002. Hydric soils of the United States.
- Hurt, G.W., and L.M. Vasilas, editors. Version 6.0, 2006. Field indicators of hydric soils in the United States.
- National Research Council. 1995. Wetlands: Characteristics and boundaries.
- Soil Survey Division Staff. 1993. Soil survey manual. Soil Conservation Service. U.S. Department of Agriculture Handbook 18. http://www.nrcs.usda.gov/wps/portal/nrcs/detail/national/soils/?cid=nrcs142p2_054262
- Soil Survey Staff. 1999. Soil taxonomy: A basic system of soil classification for making and interpreting soil surveys. 2nd edition. Natural Resources Conservation Service, U.S. Department of Agriculture Handbook 436. http://www.nrcs.usda.gov/wps/portal/nrcs/detail/national/soils/?cid=nrcs142p2_053577
- Soil Survey Staff. 2010. Keys to soil taxonomy. 11th edition. U.S. Department of Agriculture, Natural Resources Conservation Service. http://www.nrcs.usda.gov/wps/portal/nrcs/detail/national/soils/?cid=nrcs142p2_053580
- Tiner, R.W., Jr. 1985. Wetlands of Delaware. U.S. Fish and Wildlife Service and Delaware Department of Natural Resources and Environmental Control, Wetlands Section.
- United States Army Corps of Engineers, Environmental Laboratory. 1987. Corps of Engineers wetlands delineation manual. Waterways Experiment Station Technical Report Y-87-1.
- United States Department of Agriculture, Natural Resources Conservation Service. National forestry manual. http://www.nrcs.usda.gov/wps/portal/nrcs/detail/soils/home/?cid=nrcs142p2_053374
- United States Department of Agriculture, Natural Resources Conservation Service. National range and pasture handbook. <http://www.nrcs.usda.gov/wps/portal/nrcs/detail/national/landuse/rangepasture/?cid=stelprdb1043084>

Custom Soil Resource Report

United States Department of Agriculture, Natural Resources Conservation Service. National soil survey handbook, title 430-VI. http://www.nrcs.usda.gov/wps/portal/nrcs/detail/soils/scientists/?cid=nrcs142p2_054242

United States Department of Agriculture, Natural Resources Conservation Service. 2006. Land resource regions and major land resource areas of the United States, the Caribbean, and the Pacific Basin. U.S. Department of Agriculture Handbook 296. http://www.nrcs.usda.gov/wps/portal/nrcs/detail/national/soils/?cid=nrcs142p2_053624

United States Department of Agriculture, Soil Conservation Service. 1961. Land capability classification. U.S. Department of Agriculture Handbook 210. http://www.nrcs.usda.gov/Internet/FSE_DOCUMENTS/nrcs142p2_052290.pdf