

STANDARD SPECIFICATIONS

Engineering: ASCE 7-10/7-16/CPP Wind Tunnel Tested
Grounding: Fully Integrated UL2703
Foundation: Dual Ground Screw
Tilt Angles: 5°-35° Tilt Options
Racking Coating: Galvanized; G90
Foundation Coating: HDG
Wind Loading: Up to 165mph
Snow Loading: Up to 100psf
Mounting Orientation: 2-High in Portrait
Warranty: 25 Years

DUAL GROUND SCREWS

TITAN Duo is designed to tackle the most challenging sites. It's dual ground screw foundation is the ideal solution for sites with glacial till, cobble, hardpan, or solid bedrock. The heavy walled tube and welded connections allow for massive amounts of torque and pressure to be applied, helping the screw advance into the toughest soils.

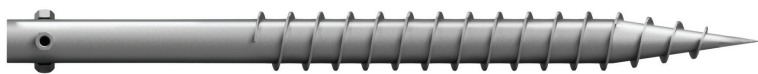

TITAN^{DUO} 4-RAIL DESIGN

Designed by installers for installers, TITAN™ is the most advanced hardware in the industry. TITAN's innovative features allow for flexibility in the field while streamlining the install process. With the lowest part count per MW and integrated grounding and cable trays, TITAN is installers preferred choice. The 4-rail design is an excellent solution for areas with high snow loads and large format modules. TITAN Duo comes standard with dual 3" diameter ground screws to manage rocky soil conditions.

In business since 2008, APA offers a versatile line of racking and foundation solutions for projects in even the most challenging environments. With projects nationwide, APA is a trusted racking partner.

WHY USE TITAN DUO™ 4-RAIL?

WIRE MANAGEMENT

Integrated cable trays and custom wire clips keep your project organized, safe, and code compliant for the life of the project, without adding costly third-party solutions.

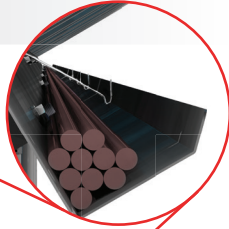

4-RAIL DESIGN

- Capable of handling snow loads up to 100psf
- Works with large format modules
- 2-High Portrait, ideal for split cell modules
- Low back panel shading for bifacial modules



ADJUSTABLE BRACING

C-channel bracing allows for easy adjustments in the field.

TELESCOPING POST

Allows for quick adjustment in the field for high degrees of topography on site.

GROUND SCREWS STANDARD

TITAN Duo is specifically designed for sites with glacial till, cobble, hardpan and bedrock.



TITAN DUO



APA
SOLAR RACKING

STRUCTURAL PRINT PACKAGE

RIDGEVILLE CORNERS, OH 43555

SAMPLE

RACKING PROVIDER



20-345 COUNTY ROAD X
RIDGEVILLE CORNERS, OHIO 43555
(P) 419.267.5280
(F) 419.267.5214
WWW.APASOLAR.COM

STRUC. ENGINEER OF RECORD

RACKING PRODUCT LINE



USE WITH THE FOLLOWING PRINTS & PACKAGES. INCLUDE WITH SUBMISSION TO PERMIT/INSPECTION AGENCY:

- CALCULATION PACKAGE: SAMPLE CALC SET - STAMPED
- FOUNDATION DESIGN REPORT (SITE SPECIFIC, & ONLY WHERE REQUIRED BY EOR OR AHJ)

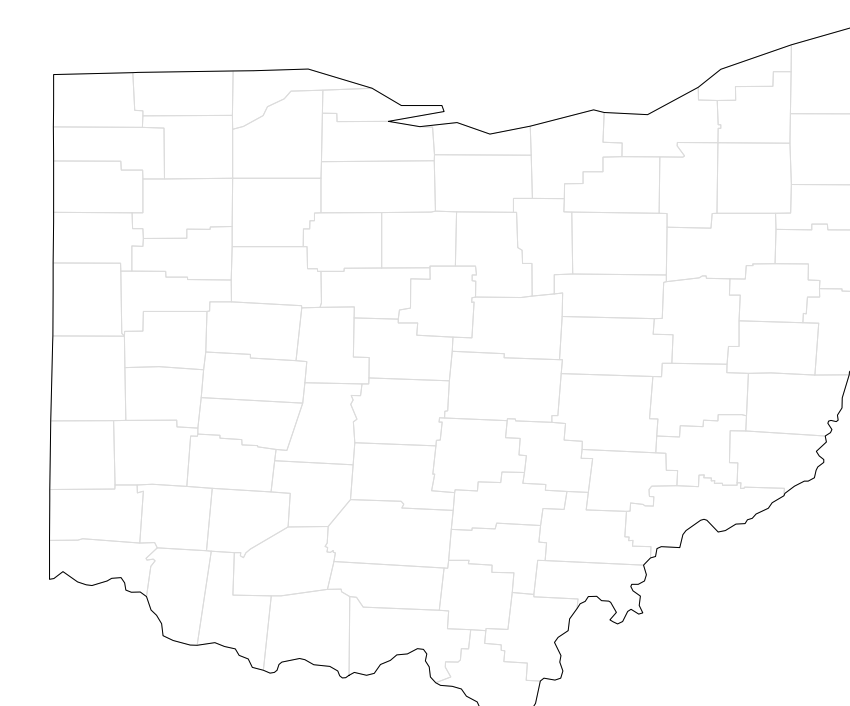

SITE ADDRESS: 20-345 COUNTY ROAD X
RIDGEVILLE CORNERS, OH 43555

REVISION: A

PERMIT SET/
STRUCTURAL PACKET

APPROVED

SOLAR PHOTOVOLTAIC GROUND MOUNT

SHEET INDEX		
STRUCTURAL		
S-000	A	STRUCTURAL COVER
S-100	A	RACKING OVERVIEW
S-200	A	GROUND SCREW
S-300	A	STRUCTURAL COMPONENTS
S-400	A	CONNECTIONS
S-500	A	STRUCTURAL PURLINS
S-600	A	CLAMPS & BRACES

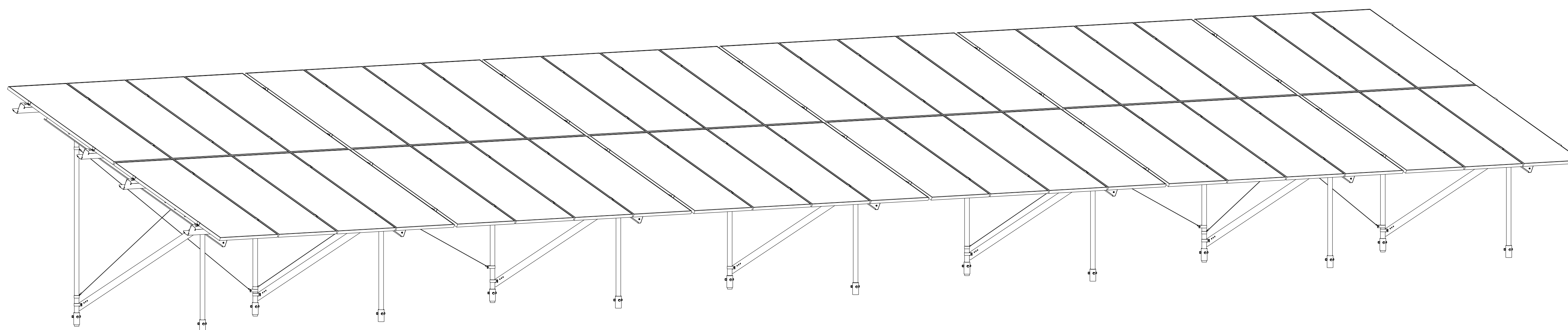

GOVERNING STRUCTURAL CODE/S
2018 INTERNATIONAL BUILDING CODE

PACKAGE COVERAGE - LOADING AND SETUP RANGES & CONSTANTS

TILT ANGLES: 20°
MAX GROUND SNOW LOAD (PSF): 40
MAX WIND LOADS (MPH): 105
WIND EXPOSURE CATEGORY: C
MAX SEISMIC Ss: 0.169 g
MAX SEISMIC S1: 0.048 g

PV MODULE: BYD MSTK-33

MAX. PANEL WIDTH: 51.30"
MAX. PANEL LENGTH: 93.86"
MAX. PANEL HEIGHT: 2.00"
MAX. PANEL WEIGHT: 80.00 LBS

RISK CATEGORY: I
MAX FRONT LIP CLEARANCE: 48"

IMAGE FOR REFERENCE ONLY

2/28/2025 2:33:18 PM SHANNON 03-29-25 1:13pm\work\sample structural\docs\prints\20-345\20-345_1.rvt SHANNON

PROPRIETARY AND CONFIDENTIAL THE INFORMATION CONTAINED IN THIS DRAWING IS THE SOLE PROPERTY OF AP. ALTERNATES, LLC. ANY REPRODUCTION IN PART OR AS A WHOLE WITHOUT THE EXPRESS WRITTEN PERMISSION IS PROHIBITED.

SCALE IS REDUCED WHEN SHEET SIZE IS 11" x 17"

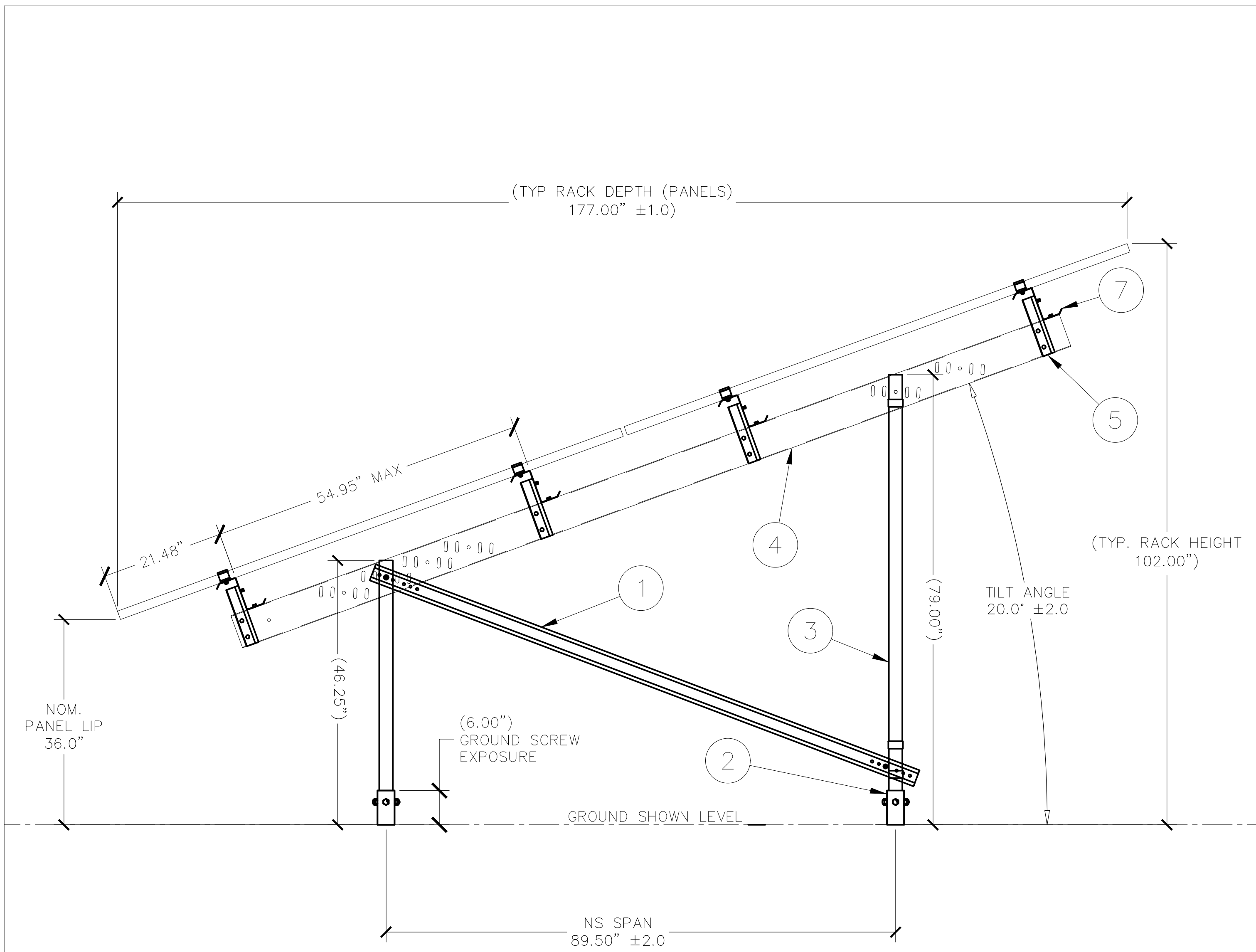

NOTES: PV MODULE & MODULE RELATED DIMENSIONS THIS DETAIL ARE MAX ALLOWABLE, UNLESS SPECIFIED ELSEWHERE IN THIS PACKET. DIMENSIONS TO GROUND ARE NOMINAL FROM LEVEL GROUND.

C1 PROFILE VIEW: RACK OVERVIEW

PARTS LIST (BALLOONS THIS SHEET)			
ITEM	DESCRIPTION	SHAPE	DETAIL / SHEET
1	KNEE BRACE	CEE	B2 / S.300
2	GROUND SCREW	POST	D2 / S.200
3	FOUNDATION POST	POST	A6 / S.300
4	NS CHORD	CEE	D1 / S.300
5	ROLL BAR	MIXED	A4 / S.300
6	TRANSVERSE BRACE	HAT	D5 / S.600
7	ZEE PURLIN	ZEE	E1 / S.300
8	CABLE BRACE	CABLE	D4 / S.600

SEE VIEW A1 ON S600 FOR VIEW OF TRANSVERSE BRACE

- NOTES:
- STANDARD FRONT LIP HEIGHT AND TILT ANGLES MEASURED FROM LEVEL GROUND
 - FOUNDATION TESTING, WHERE REQUIRED, SHALL BE DONE ACCORDING TO THE "QUICK TEST METHOD" PER ASTM D1143 & D3689.
 - PRINT DIMENSIONS: DIMENSIONS SHOWN REFLECT POST HEIGHTS ON LEVEL GROUND. ON UNEVEN TERRAIN, REAR FOUNDATION POST HEIGHT WILL BE DICTATED BY FRONT LIP HEIGHT, PANEL TILT, AND NORTH/SOUTH POST SPACING.
 - ADDITIONAL TOLERANCES: POST PLUMBNESS SHOULD BE WITHIN ±2"
 - SPECIAL INSPECTIONS (WHERE REQUIRED):

SPECIAL INSPECTIONS ARE NOT REQUIRED BY APA SOLAR OR THE STRUCTURAL ENGINEER OF RECORD. WHERE REQUIRED BY OWNER, CUSTOMER, AND/OR AUTHORITY HAVING JURISDICTION, MINIMUM INSPECTION SHALL FOLLOW IBC OR LOCAL AHJ SPECIAL INSPECTIONS GUIDELINES.

CUSTOMER

RACKING PROVIDER

APA SOLAR RACKING
 20-345 COUNTY ROAD X
 RIDGEVILLE CORNERS, OHIO 43555
 (P) 419.267.5280
 (F) 419.267.5214
 WWW.APASOLAR.COM

RACKING TYPE

TITAN

PROFESSIONAL SEAL/STAMP

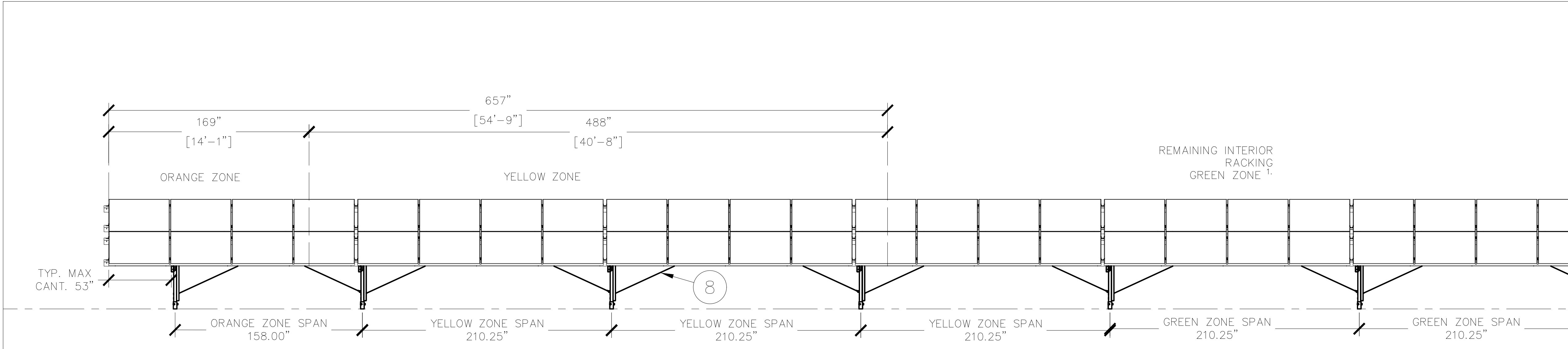

NOTES: MAX CANTILEVER MEASURED FROM EDGE OF PANEL TO POST CENTER.
 MAX SPAN MEASURED FROM PILE CENTER TO PILE CENTER.
 POST QUANTITY AS REQUIRED TO SATISFY CANTILEVERS, SPANS, ROW LENGTH, & PANEL QUANTITY.
 1. WHERE ALLOWABLE PER THE CALCULATIONS PACKAGE, PROHIBITED AREAS SHALL REMAIN ZONED YELLOW.

A1 ELEVATION VIEW FROM FRONT (NORTH-FACING)

IMAGE REFERENCE ONLY. NOT INDICATIVE OF REQUIRED QUANTITIES.

DOCUMENT NAME:
STRUCTURAL PRINT PACKAGE

SITE STREET ADDRESS:
20-345 COUNTY ROAD X

SITE CITY, STATE, ZIP:
RIDGEVILLE CORNERS, OH 43555

SHEET REVISIONS		DATE
REV.	DESCRIPTION	
A	INITIAL RELEASE	4/28/2023

SAMPLE

APPROVED

DRAWN	REVIEWED	APPROVED	SIZE
SDS	TM	JDI	D
SHEET NAME			
RACKING OVERVIEW			
PROJECT NUMBER			
SAMPLE			
DRAWING NUMBER		REV.	
S.100		A	

PROPRIETARY AND CONFIDENTIAL. ALL INFORMATION CONTAINED IN THIS DRAWING IS THE SOLE PROPERTY OF AP SOLAR, LLC. ANY REPRODUCTION IN PART OR AS A WHOLE WITHOUT THE EXPRESS WRITTEN PERMISSION IS PROHIBITED.

IMAGE FOR REFERENCE ONLY

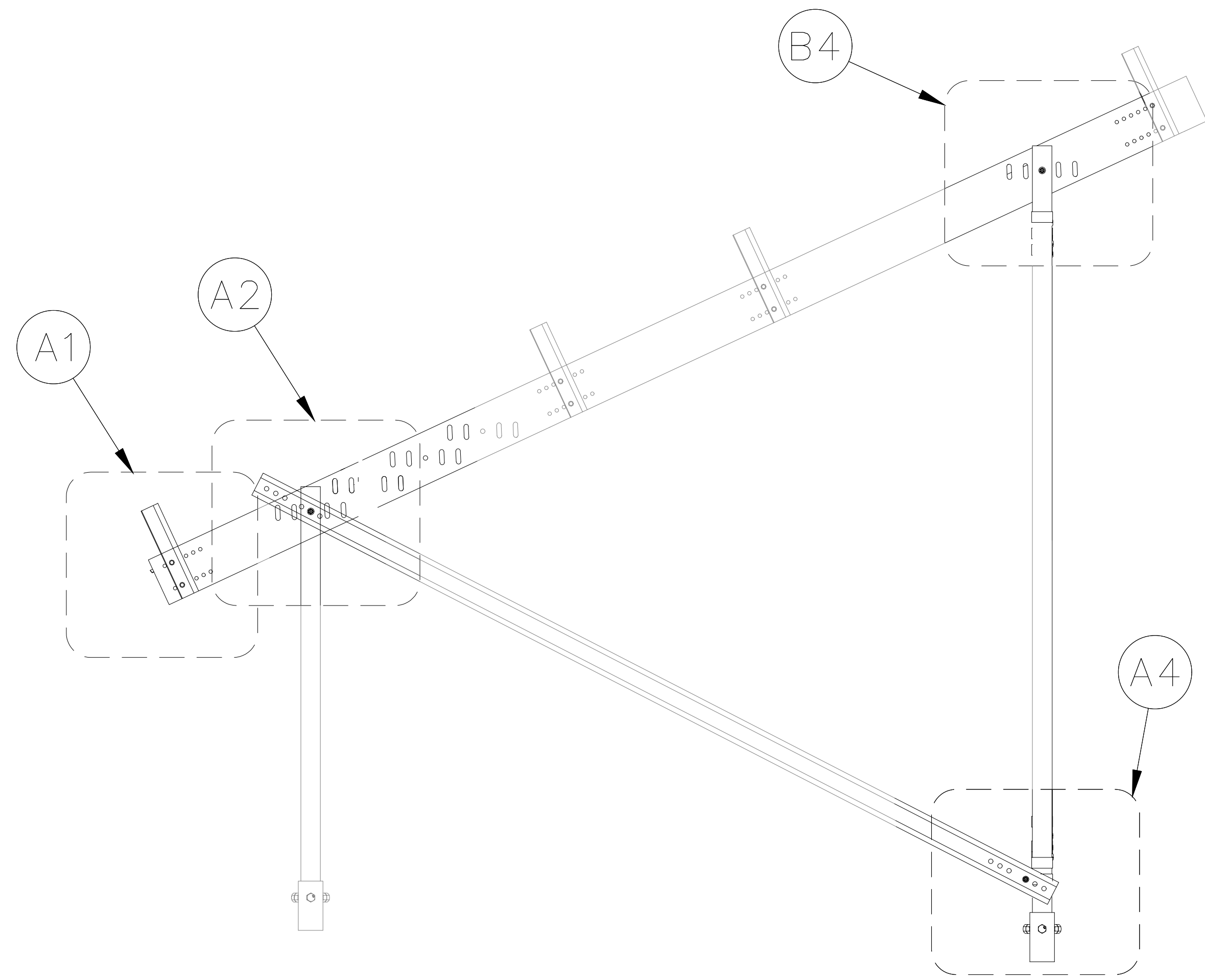

B1 FOUNDATION SET CONNECTIONS OVERVIEW

IMAGE FOR REFERENCE ONLY

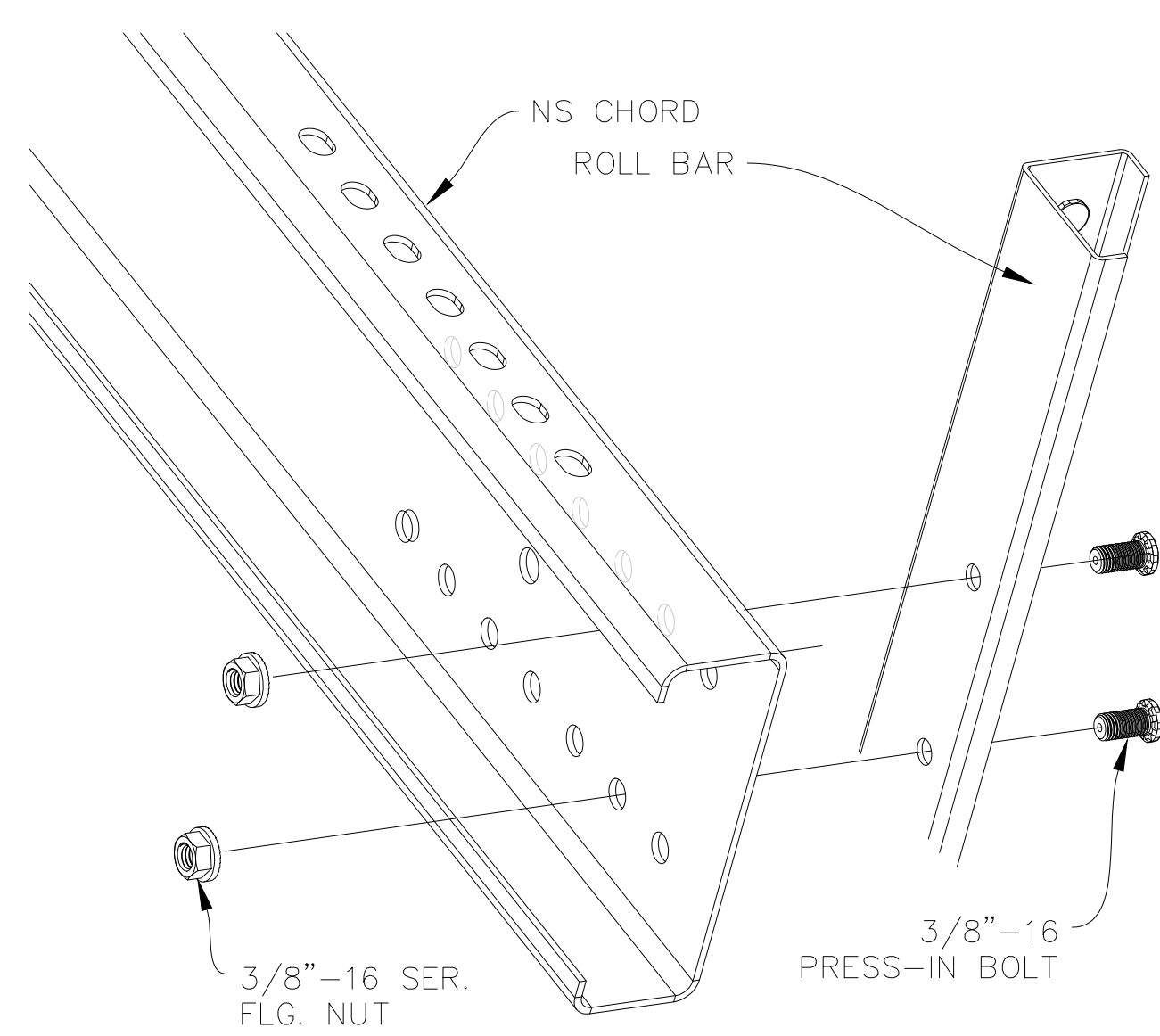

ATTACHED TO OUTER HOLE SET FOR REFERENCE ONLY. SEE NOTES.

A1 CONNECTION: ROLL BAR-TO-NS CHORD

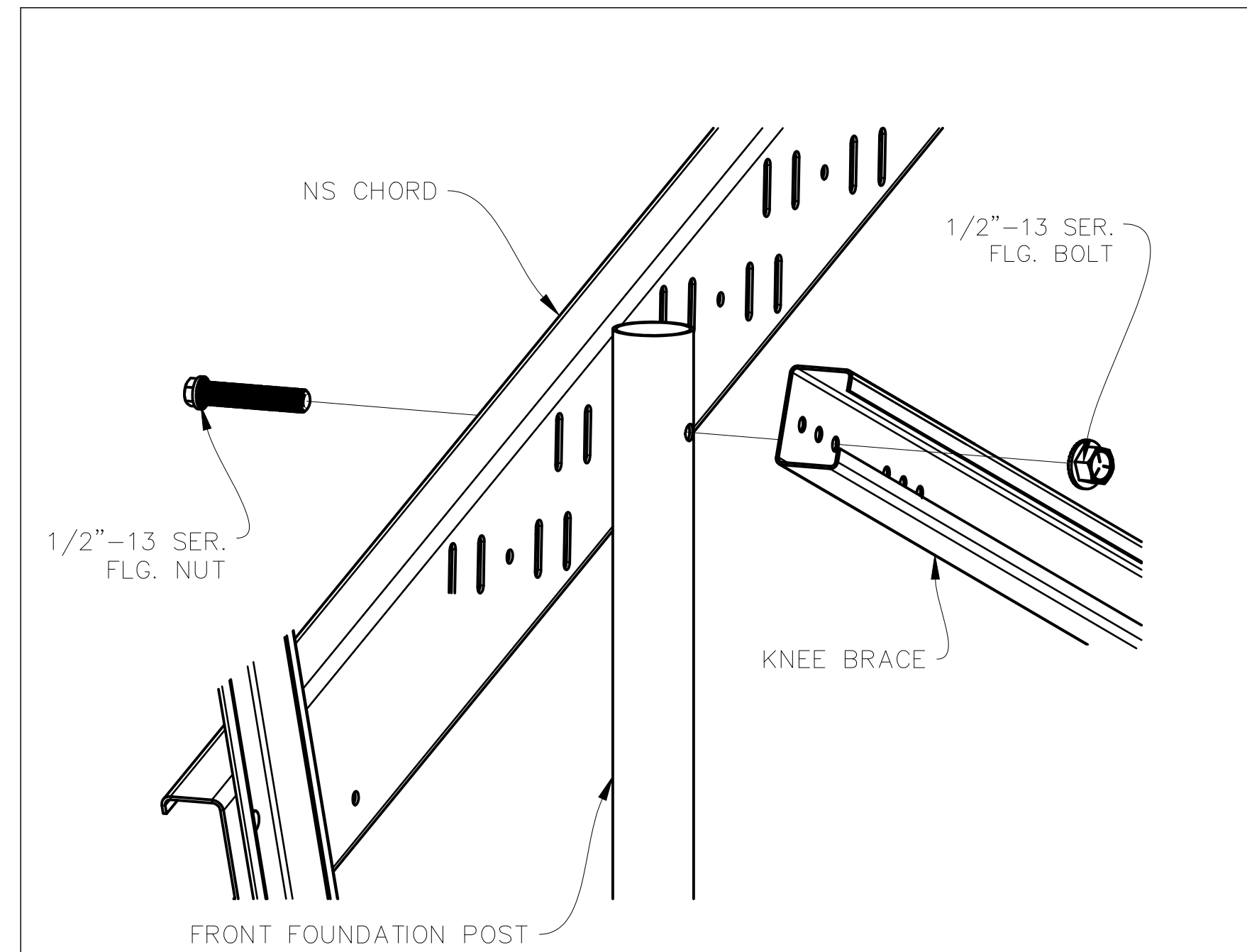

A2 CONNECTION: KNEE BRACE-TO-FRONT POST

IMAGE FOR REFERENCE ONLY

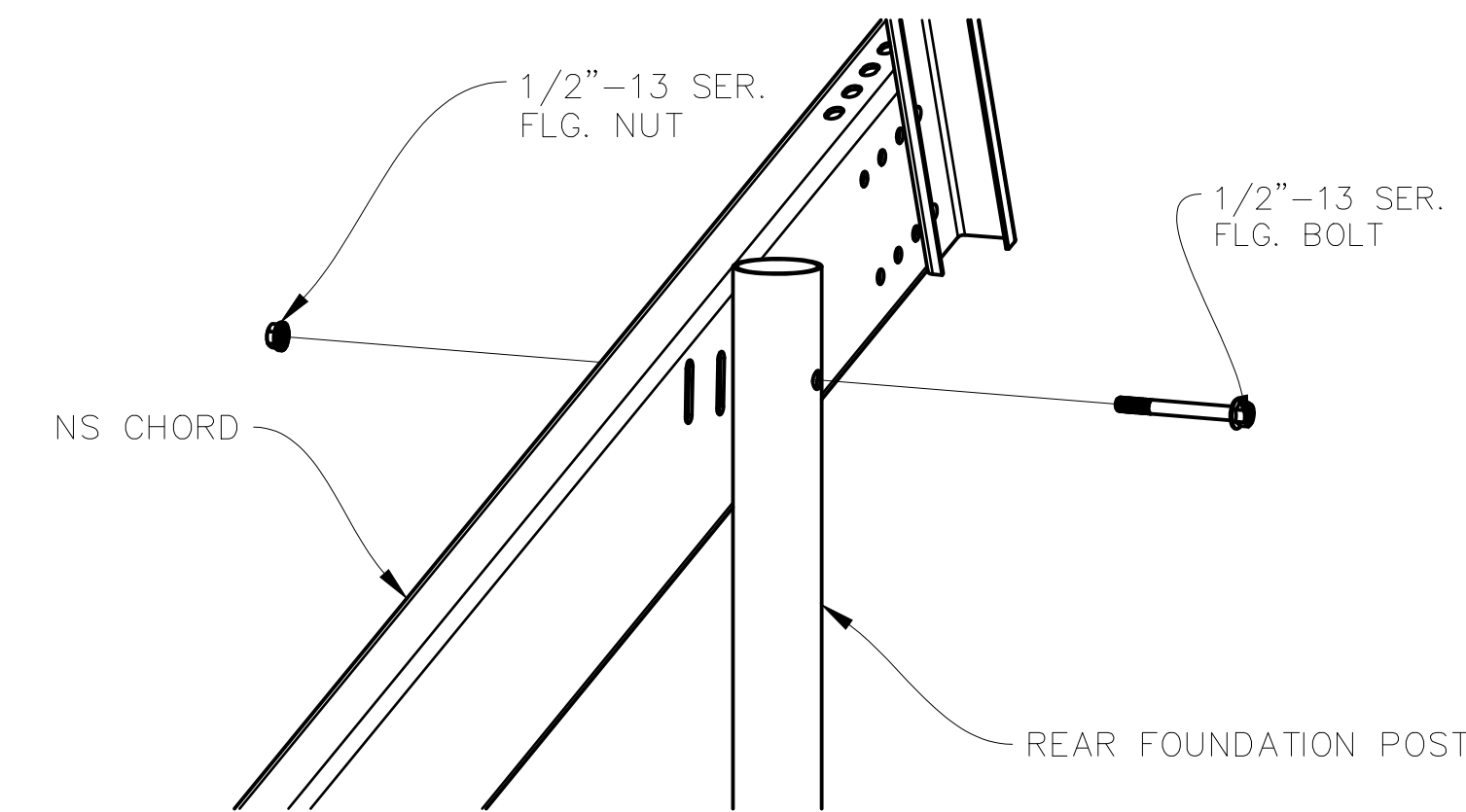

B4 CONNECTION: REAR POST-TO-NS CHORD

IMAGE FOR REFERENCE ONLY

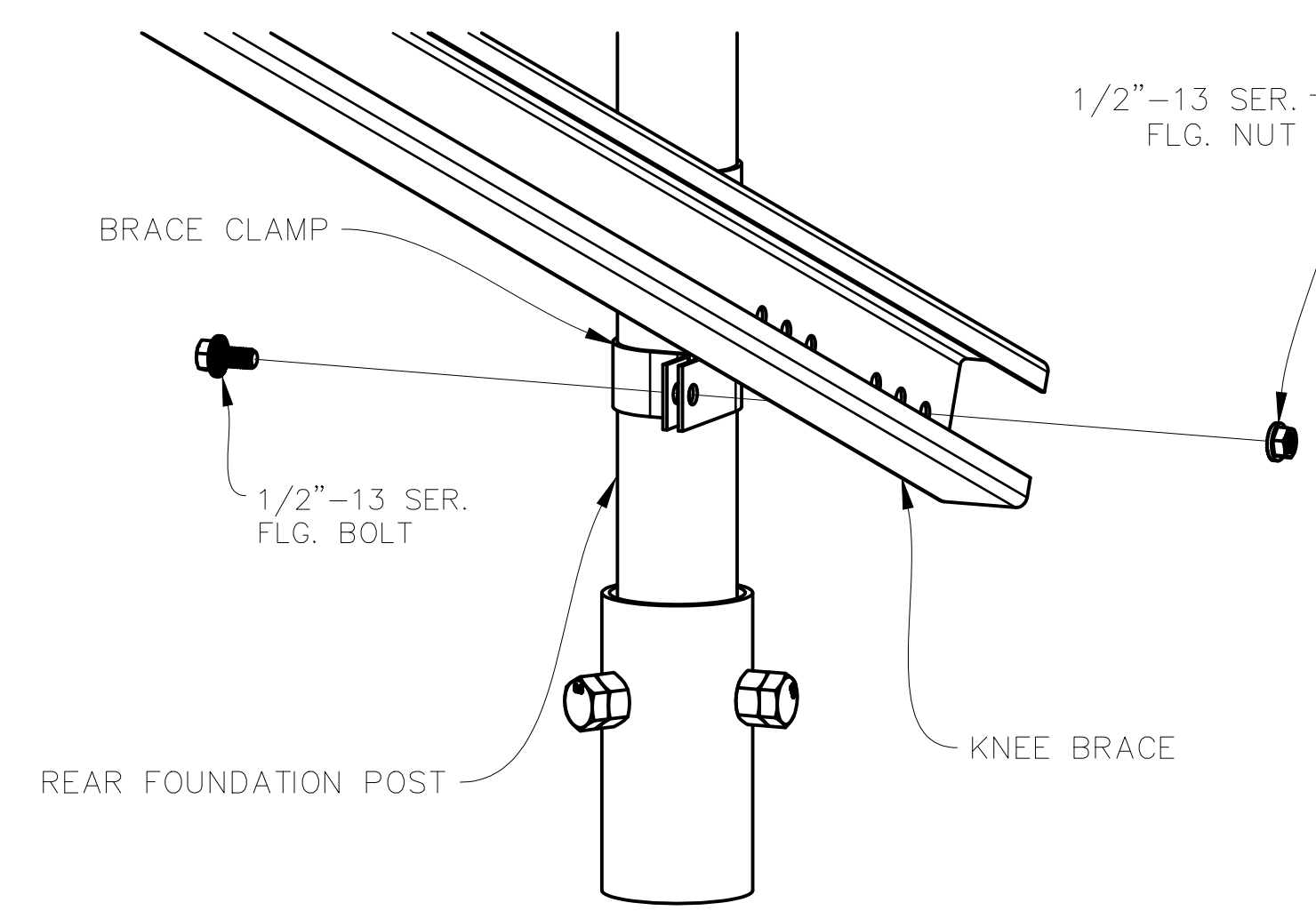

A4 KNEE BRACE-TO-REAR POST

NOTES:

- HARDWARE TORQUE VALUES:
 3/8"-16 STAINLESS STEEL
 MIN.: 17.5 FT-LBS
 NOM.: 19.6 FT-LBS
 MAX.: 50.0 FT-LBS

 1/2"-13 STAINLESS STEEL
 MIN.: 25 FT-LBS
- DEPICTED HARDWARE AND PART PLACEMENT NOT INDICATIVE OF PREFERRED OR REQUIRED POSITIONS.
- HOLE/SLOT PATTERNS IN PARTS ALLOW FOR DEVIATION FROM NOMINAL DIMENSIONS, MULTIPLE PART POSITIONS, AND MULTIPLE TILT ANGLES.
- SEE INSTALLATION MANUAL FOR SETUP INSTRUCTIONS.
- SERRATED FLANGED BOLTS MAY BE REPLACED WITH EQUIVALENT PRESS-IN BOLTS. SEE NOTE 10 FOR MORE OPTIONS.
- PRESS-IN BOLTS, WHERE PRESENT, TO BE INSTALLED TO MANUFACTURERS RECOMMENDED VALUES.
- OTHER SPECIFIC CONNECTIONS ELSEWHERE IN PRINT SET.
- ROLL BAR MUST CONNECT TO THE CORRECT HOLES IN CEE CHANNEL (INNER, OR OUTER TYPICALLY), AS DETERMINED BY PV MODULE MANUFACTURERS ALLOWABLE CLAMPING ZONE.
- USE CORRECT NOMINAL HOLES IN CEE TO CONNECT TO FOUNDATION POST, AS INDICATED. ADJACENT HOLES AND SLOTS FOR FIELD ADJUSTMENTS.
- SERRATED HARDWARE MAY BE REPLACED WITH EQUIVALENT HARDWARE WITH WASHERS IF NECESSARY.
- IN ALL DETAILS, THE PRESENCE OF TWO SETS OF HARDWARE INDICATES THE REQUIREMENT OF TWO SETS OF HARDWARE.
- STAINLESS STEEL HARDWARE MAY BE REPLACED WITH GALVANIZED STEEL HARDWARE OR CORROSION AND STRENGTH COMPARABLE HARDWARE MATERIALS AND FINISHES.
- UNLESS NOTED OTHERWISE, ALL HARDWARE MAY BE INSTALLED IN EITHER DIRECTION (NUT/BOLT MAY BE ON EITHER SIDE OF CONNECTION).
- WHEN NECESSARY, ADDITIONAL HOLES MAY BE DRILLED TO COMPLETE CONNECTION. ENGINEERING SHALL BE CONTRACTED PRIOR TO FIELD MODIFICATIONS OF PARTS.

CUSTOMER

RACKING PROVIDER

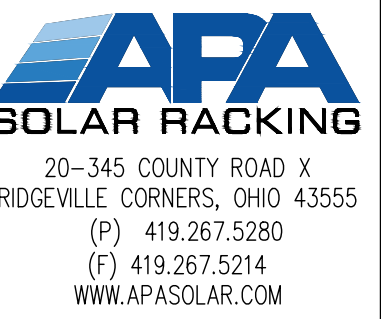

RACKING TYPE



PROFESSIONAL SEAL/STAMP

DOCUMENT NAME:
STRUCTURAL PRINT PACKAGE
 SITE STREET ADDRESS:
20-345 COUNTY ROAD X
 SITE CITY, STATE, ZIP:
RIDGEVILLE CORNERS, OH 43555

REV.	DESCRIPTION	DATE
A	INITIAL RELEASE	4/28/2023

SAMPLE

APPROVED

DRAWN	REVIEWED	APPROVED	SIZE
SDS	TM	JDI	D
SHEET NAME CONNECTIONS			
PROJECT NUMBER SAMPLE			
DRAWING NUMBER S.400		REV. A	

PROPRIETARY AND CONFIDENTIAL. ALL INFORMATION CONTAINED IN THIS DRAWING IS THE SOLE PROPERTY OF AP ALTERNATIVES, LLC. ANY REPRODUCTION IN PART OR AS A WHOLE WITHOUT THE EXPRESS WRITTEN PERMISSION IS PROHIBITED.

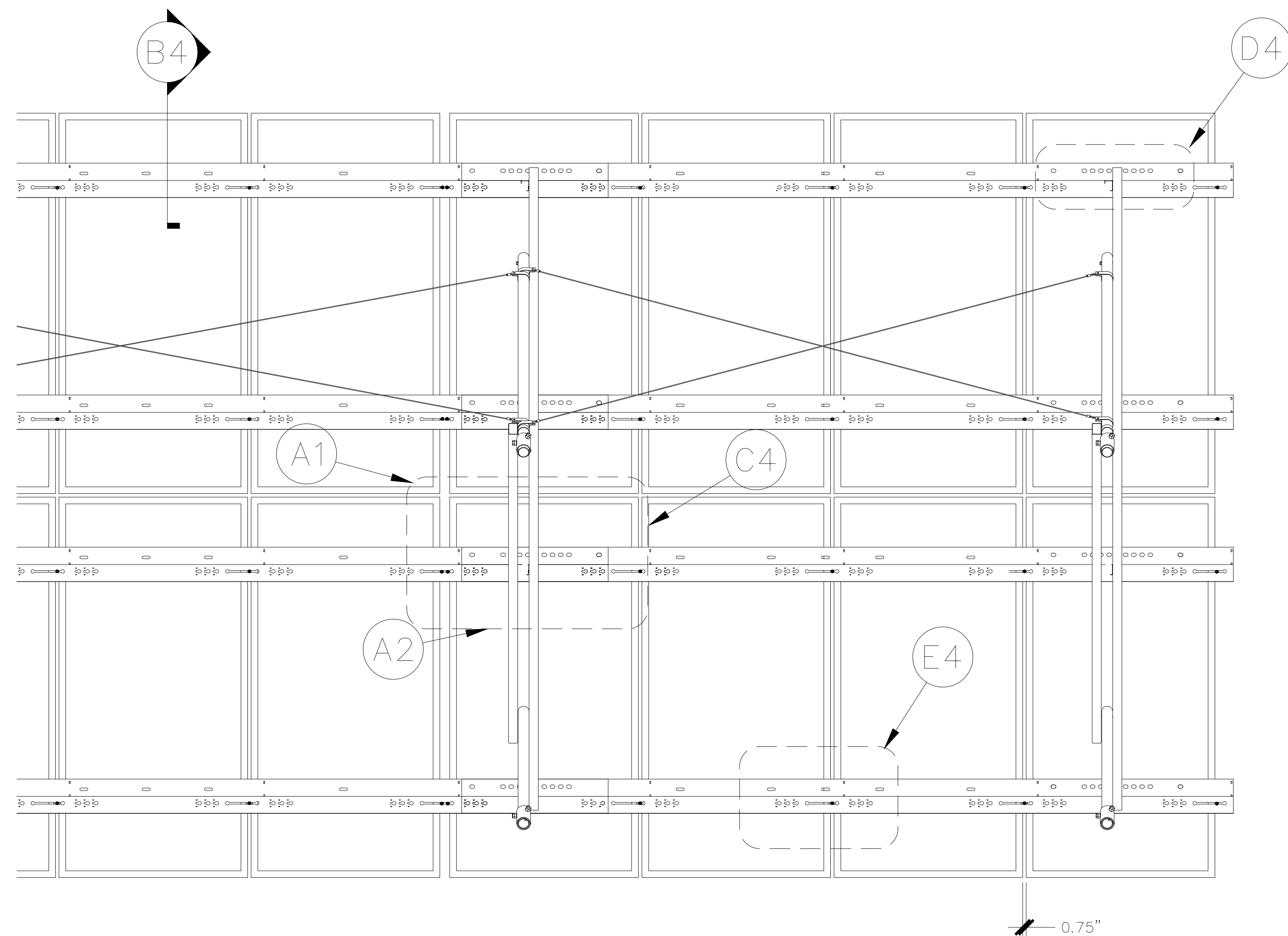

B1 OVERVIEW: ZEE PURLIN CONNECTIONS (RACK UNDERSIDE)

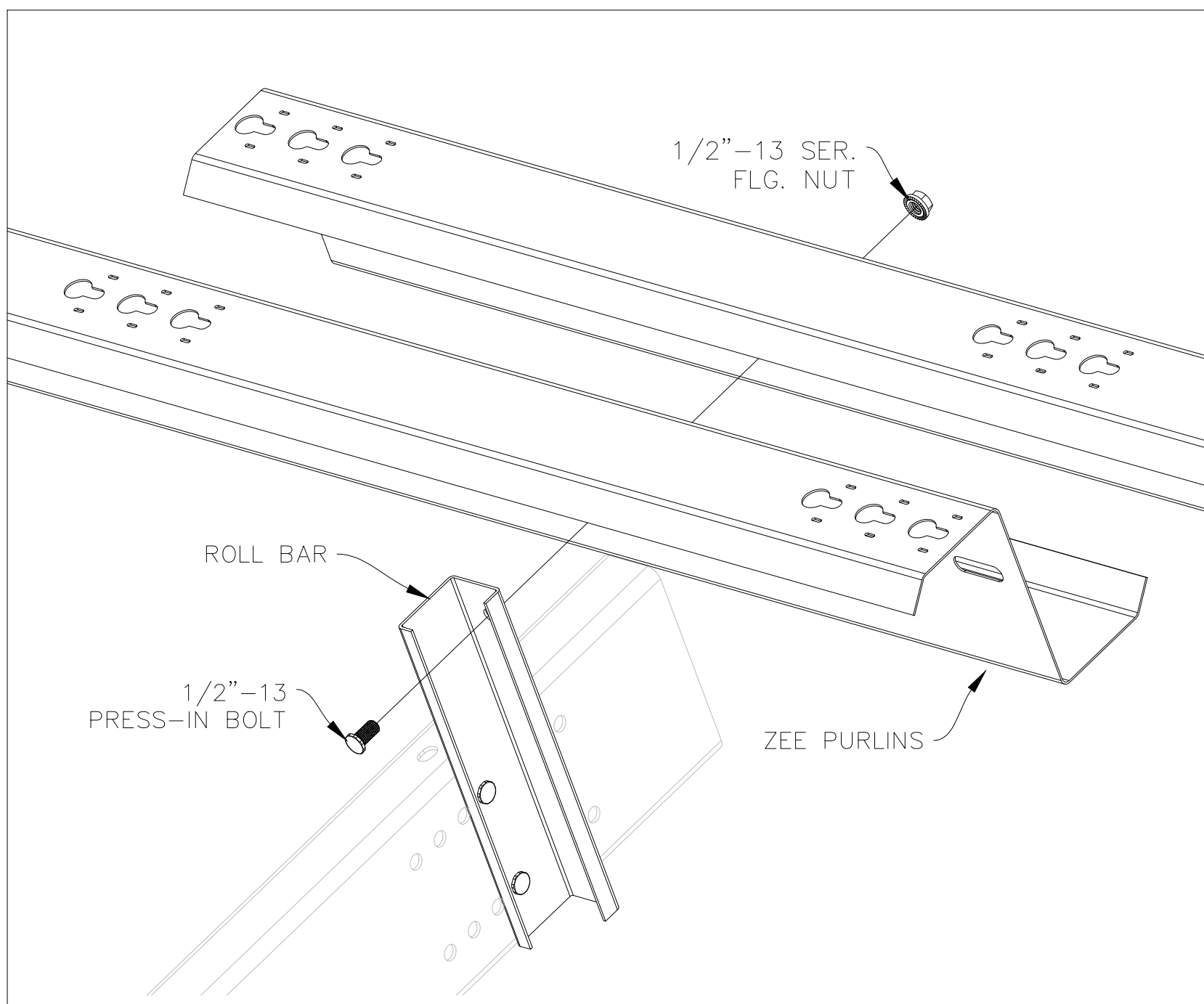

A1 CONNECTION: ZEE PURLINS-TO-ROLL BAR

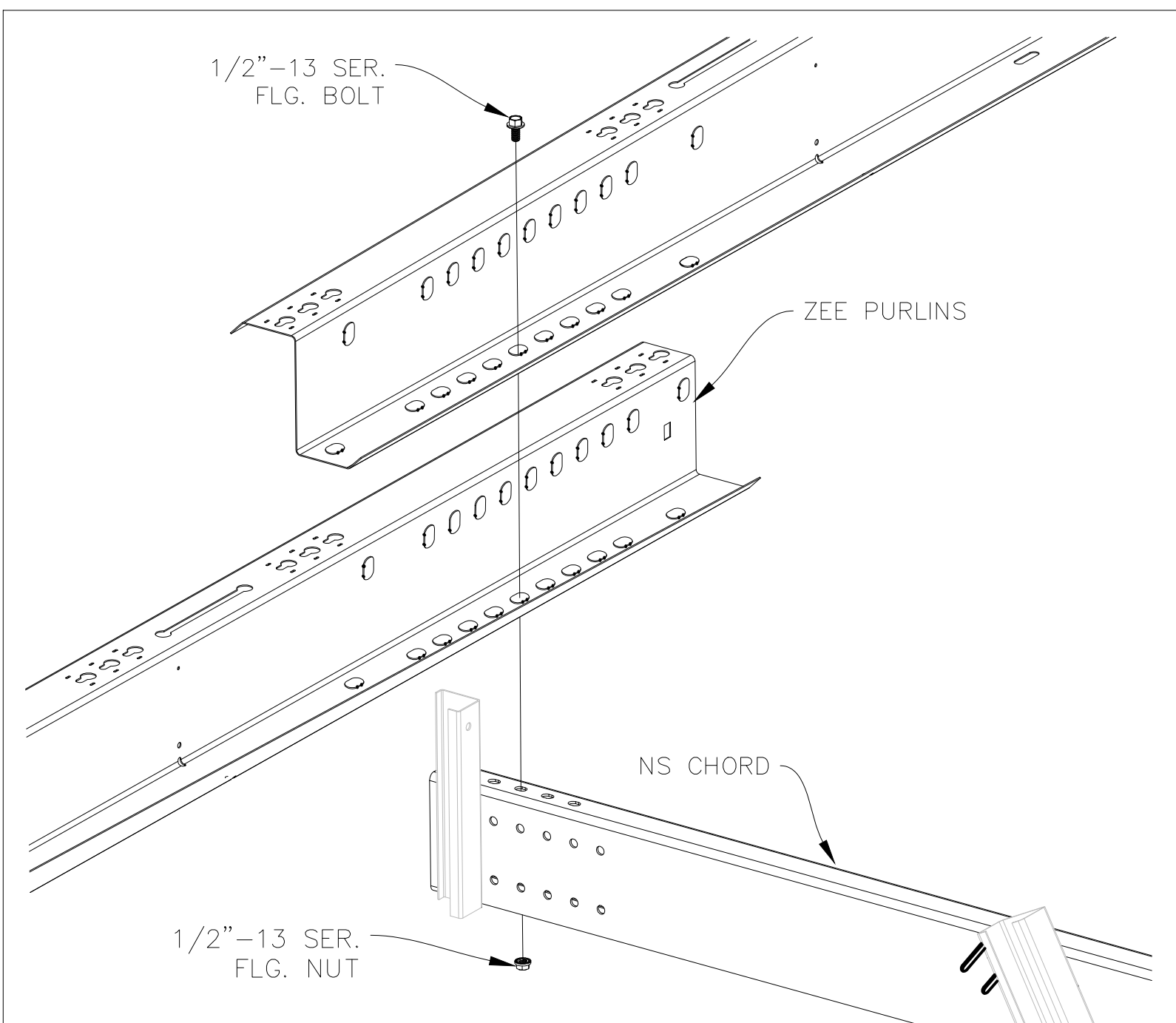

A2 CONNECTION: ZEE PURLINS-TO-NS CHORD

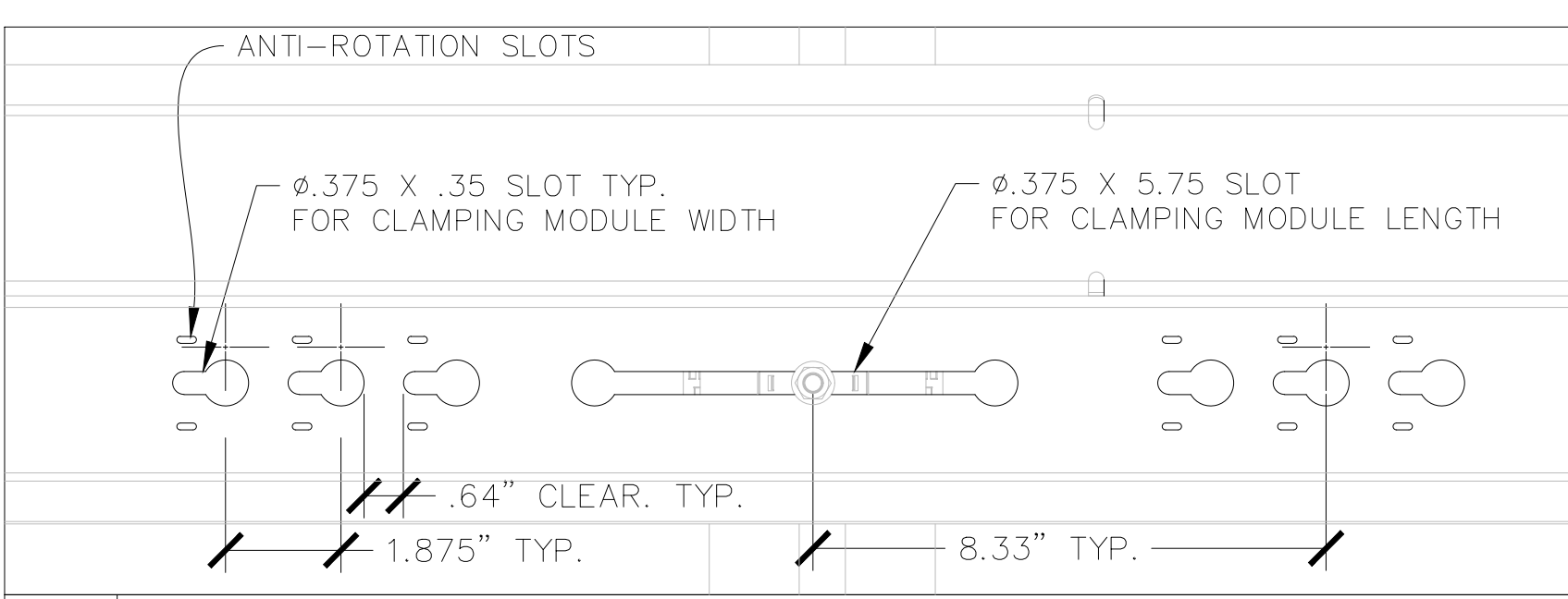

E4 DETAIL: ZEE PURLIN PANEL SLOTS

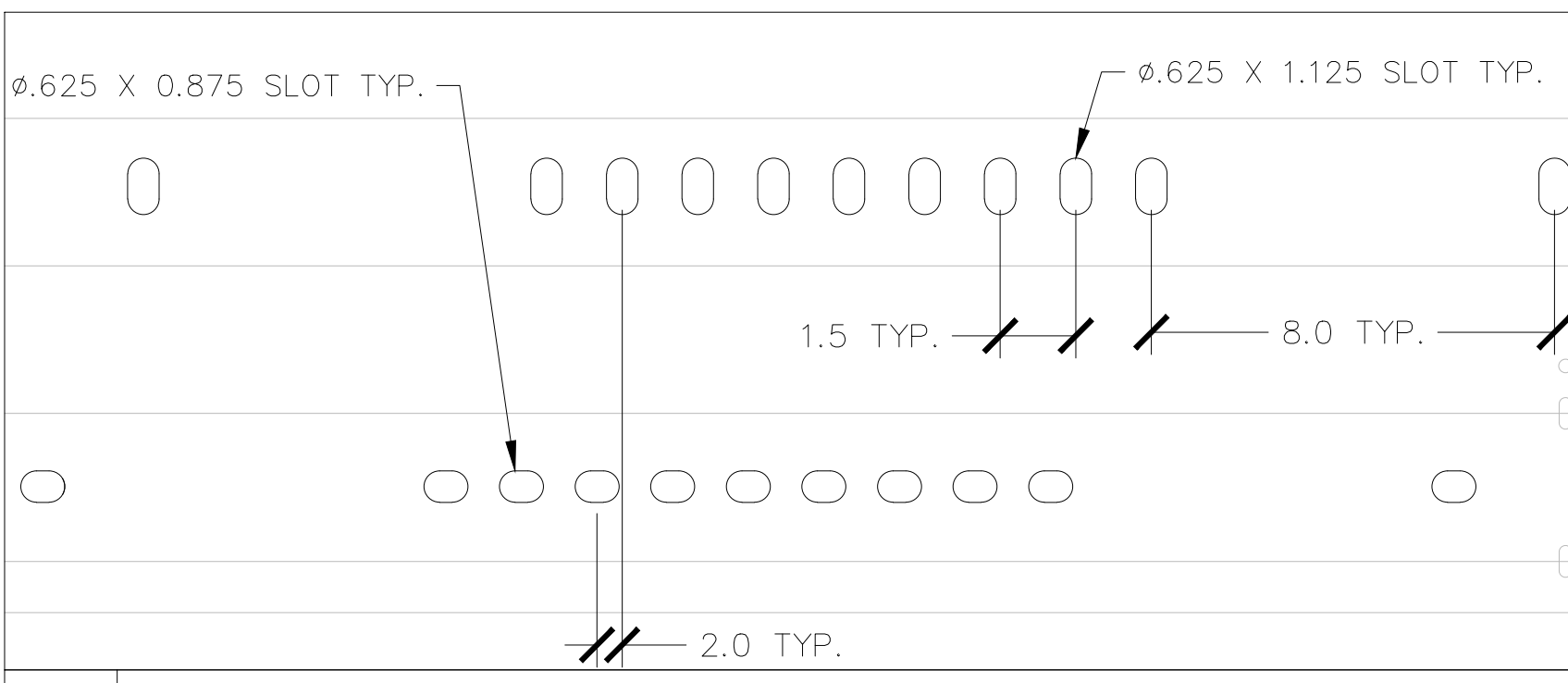

D4 DETAIL: ZEE PURLIN SPLICE SLOTS

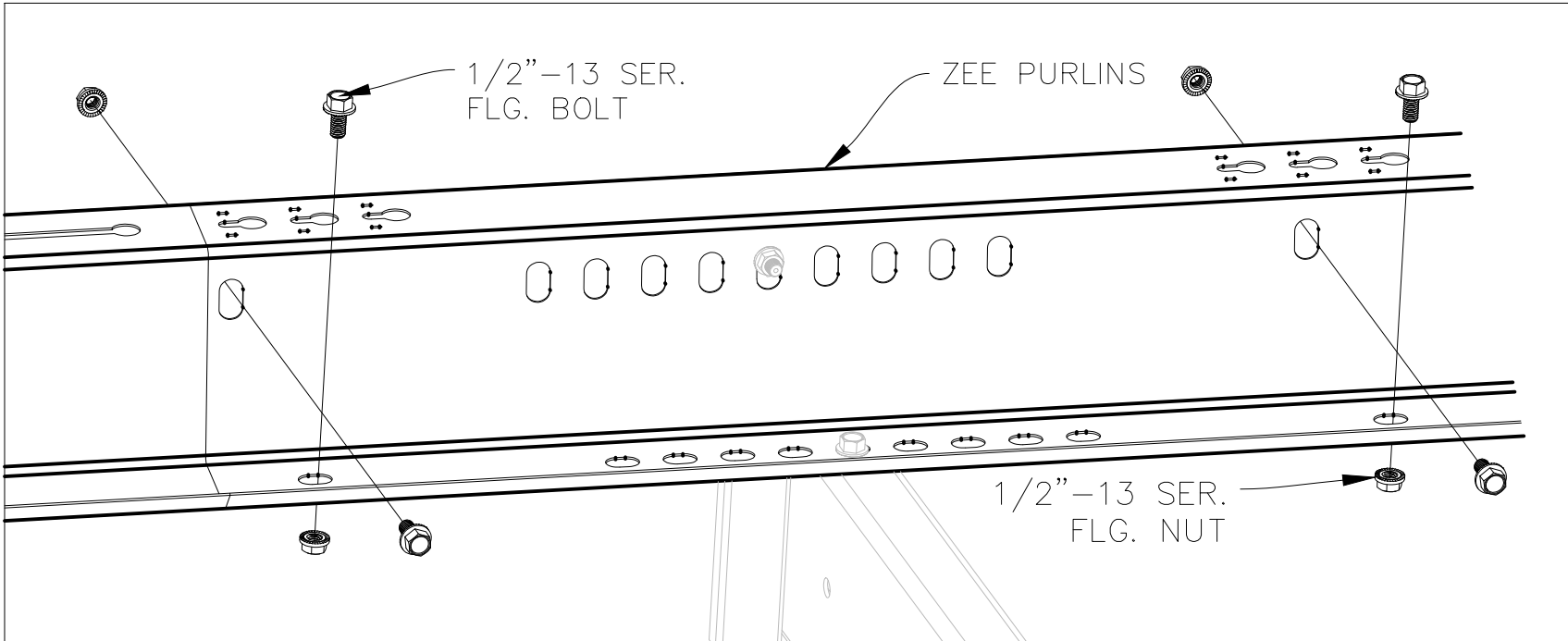

C4 CONNECTION: ZEE-TO-ZEE PURLINS SPLICE

- NOTES:**
- HARDWARE TORQUE VALUES:**
 3/8"-16 STAINLESS STEEL
 MIN.: 17.5 FT-LBS
 NOM.: 19.6 FT-LBS
 MAX.: 50.0 FT-LBS
 - DEPICTED HARDWARE AND PART PLACEMENT NOT INDICATIVE OF PREFERRED OR REQUIRED POSITIONS.
 - HOLE/SLOT PATTERNS IN PARTS ALLOW FOR DEVIATION FROM NOMINAL DIMENSIONS, MULTIPLE PART POSITIONS, AND MULTIPLE TILT ANGLES.
 - SEE INSTALLATION MANUAL FOR SETUP INSTRUCTIONS.
 - SERRATED FLANGED BOLTS MAY BE REPLACED WITH EQUIVALENT PRESS-IN BOLTS.
 - PRESS-IN BOLTS, WHERE PRESENT, TO BE INSTALLED TO MANUFACTURERS RECOMMENDED VALUES.
 - OTHER SPECIFIC CONNECTIONS ELSEWHERE IN PRINT SET.
 - SERRATED HARDWARE MAY BE REPLACED WITH EQUIVALENT HARDWARE WITH WASHERS IF NECESSARY.
 - IN ALL DETAILS, THE PRESENCE OF TWO SETS OF HARDWARE INDICATES THE REQUIREMENT OF TWO SETS OF HARDWARE.
 - STAINLESS STEEL HARDWARE MAY BE REPLACED WITH GALVANIZED STEEL HARDWARE OR CORROSION AND STRENGTH COMPARABLE HARDWARE MATERIALS AND FINISHES.
 - UNLESS NOTED OTHERWISE, ALL HARDWARE MAY BE INSTALLED IN EITHER DIRECTION (NUT/BOLT MAY BE ON EITHER SIDE OF CONNECTION).
 - WHEN NECESSARY, ADDITIONAL HOLES MAY BE DRILLED TO COMPLETE CONNECTION. ENGINEERING SHALL BE CONTRACTED PRIOR TO FIELD MODIFICATIONS OF PARTS.
 - CONNECTION IN DETAIL A1 & A2 SHOWN IN NOMINAL POSITION. ACTUAL CONNECTION MAY BE ±8".
 - WHEN CONNECTIONS IN DETAIL A1 & A2 ARE AT THEIR MAX/MIN POSITIONS (±2") INTERFERING SPLICE HARDWARE MAY BE RELOCATED TO NEXT NEAREST SLOTS.
 - WHERE PRESENT, TRANSVERSE BRACE MAY UTILIZE LOWER SPLICE BOLTS. SEE CONNECTIONS SHEET FOR MORE INFORMATION.
 - ZEE-TO-ZEE SPLICE SHALL ALWAYS OVERLAP MINIMUM 32", AS INDICATED, EXCEPT AT ENDS OF ROW, WHERE NO SPLICE IS REQUIRED.
 - SPLICE MAY OVERLAP IN EITHER DIRECTION.
 - ZEE PURLIN MATERIAL AND FINISH ARE MANUFACTURED TO SPECIFICATIONS THAT MEET OR EXCEED OUR STANDARD PRODUCT WARRANTY.
 - ZEE PURLINS GALVANIZED TO CONFORM TO A MINIMUM THICKNESS DESIGNATION EQUAL TO G90 OR INLINE GALVANIZED TO COMPARABLE THICKNESS AS PER ASTM A1057.
 - TYPICAL ZEE PURLIN RETURN LIP ANGLE SHOWN. ACTUAL ANGLE MAY VARY.
 - SLOT DIMENSIONS FOR REFERENCE ONLY. FINAL SHAPE, FREQUENCY, AND DIMENSIONS MAY VARY.
 - LENGTH OF PURLIN VARIES BY PROJECT AND LOCATION WITHIN ARRAY.

CUSTOMER

RACKING PROVIDER

APA SOLAR RACKING
 20-345 COUNTY ROAD X
 RIDGEVILLE CORNERS, OHIO 43555
 (P) 419.267.5280
 (F) 419.267.5214
 WWW.APASOLAR.COM

RACKING TYPE

TITAN

PROFESSIONAL SEAL/STAMP

DOCUMENT NAME: **STRUCTURAL PRINT PACKAGE**

SITE STREET ADDRESS: **20-345 COUNTY ROAD X**

SITE CITY, STATE, ZIP: **RIDGEVILLE CORNERS, OH 43555**

SHEET REVISIONS		DATE
REV.	DESCRIPTION	
A	INITIAL RELEASE	4/28/2023

SAMPLE

APPROVED

DRAWN	REVIEWED	APPROVED	SIZE
SDS	TM	JDI	D
SHEET NAME			
STRUCTURAL PURLINS			
PROJECT NUMBER			
SAMPLE			
DRAWING NUMBER			
S.500		REV.	
		A	

SCALE IS REDUCED WHEN SHEET SIZE IS 11" x 17"

CUSTOMER

RACKING PROVIDER
APA SOLAR RACKING
 20-345 COUNTY ROAD X
 RIDGEVILLE CORNERS, OHIO 43555
 (P) 419.267.5280
 (F) 419.267.5214
 WWW.APASOLAR.COM

RACKING TYPE
TITAN
315

PROFESSIONAL SEAL/STAMP

STRUCTURAL PRINT PACKAGE
 DOCUMENT NAME
 SITE STREET ADDRESS
20-345 COUNTY ROAD X
 SITE CITY, STATE, ZIP
RIDGEVILLE CORNERS, OH 43555

REV.	DESCRIPTION	DATE
A	INITIAL RELEASE	4/28/2023

SAMPLE

APPROVED

DRAWN	REVIEWED	APPROVED	SIZE
SDS	TM	JDI	D

SHEET NAME
CLAMPS & BRACES

PROJECT NUMBER
SAMPLE

DRAWING NUMBER
S.600

REV.
A

- NOTES:
- HARDWARE TORQUE VALUES:
 1/2"-13 STAINLESS STEEL
 MIN.: 40 FT-LBS
 M8-1.25 STAINLESS STEEL
 MIN.: 14.0 FT-LBS
 NOM.: 15.6 FT-LBS
 MAX.: 25 FT-LBS
 - DEPICTED HARDWARE AND PART PLACEMENT NOT INDICATIVE OF PREFERRED OR REQUIRED POSITIONS.
 - HOLE/SLOT PATTERNS IN PARTS ALLOW FOR DEVIATION FROM NOMINAL DIMENSIONS, MULTIPLE PART POSITIONS, AND MULTIPLE TILT ANGLES.
 - SEE INSTALLATION MANUAL FOR SETUP INSTRUCTIONS.
 - SERRATED FLANGED BOLTS MAY BE REPLACED WITH EQUIVALENT PRESS-IN BOLTS. SEE NOTE 8 FOR MORE INFORMATION.
 - PRESS-IN BOLTS, WHERE PRESENT, TO BE INSTALLED TO MANUFACTURERS RECOMMENDED VALUES.
 - OTHER SPECIFIC CONNECTIONS ELSEWHERE IN PRINT SET.
 - SERRATED HARDWARE MAY BE REPLACED WITH EQUIVALENT HARDWARE WITH WASHERS IF NECESSARY.
 - STAINLESS STEEL HARDWARE MAY BE REPLACED WITH GALVANIZED STEEL HARDWARE OR CORROSION AND STRENGTH COMPARABLE HARDWARE MATERIALS AND FINISHES.
 - UNLESS NOTED OTHERWISE, ALL HARDWARE MAY BE INSTALLED IN EITHER DIRECTION (NUT/BOLT MAY BE ON EITHER SIDE OF CONNECTION).
 - WHEN NECESSARY, ADDITIONAL HOLES MAY BE DRILLED TO COMPLETE CONNECTION. ENGINEERING SHALL BE CONTRACTED PRIOR TO FIELD MODIFICATIONS OF PARTS.
 - EAST/WEST CABLE BRACING (C1) TO BE INSTALLED IN THE SPACE BETWEEN ANCHOR SETS (BAY).
 - MINIMUM CABLE BREAKING STRENGTH DETERMINED BY PROJECT SPECIFIC STRUCTURAL CALCULATIONS.
 - CABLE TO BE STAINLESS STEEL AIRCRAFT CABLE.
 - CABLE MAY BE OF ANY CONFIGURATION (IE. 7X7 OR 7X19) AS LONG AS IT MEETS THE REQUIREMENTS LISTED ON THIS SHEET.
 - LENGTH OF BRACES WILL VARY DEPENDENT ON PROJECT SPECIFICS.
 - TRANSVERSE BRACE SETS SHALL BE INSTALLED AT FREQUENCY INDICATED.
 - TRANSVERSE BRACES ARE NOT A REQUIREMENT OF THE STRUCTURAL MODELS. APA REQUIRES THEIR PRESENCE AS AN ASSEMBLY AID ONLY.
 - DUE TO IT'S NON-STRUCTURAL NATURE, TRANSVERSE BRACE PROFILE, THICKNESS, MATERIAL, STRENGTH, COATING, FREQUENCY, AND INSTALLATION MAY CHANGE AT ANY TIME AT THE DISCRETION OF APA, BY APPROVAL OF APA ENGINEERING.
 - WHERE TRANSVERSE BRACE CANNOT BE INSTALLED DUE TO NS CHORD (OUT OF NOMINAL LOCATION), BRACE SHALL BE RELOCATED TO NEXT NEAREST REASONABLE SPLICE.
 - TRANSVERSE BRACE MAY UTILIZE LOWER SPLICE BOLTS, WHERE PRESENT. SEE PURLIN SHEET FOR MORE INFORMATION.
 - EACH PV MODULE SHALL BE CLAMPED IN 4 PLACES.
 - A MAJORITY OF THE CLAMP BOLT FLANGES MUST TERMINATE OVER THE SLOT, AND NOT OVER THE KEYHOLE.
 - SPRING, & PANEL GUIDE MAY NOT BE PRESENT AT ALL LOCATIONS, OR ANY LOCATIONS.
 - ALL PANELS MUST BE GROUNDED/BONDED TO ZEE PURLINS. THIS MAY BE ACCOMPLISHED WITH THE PANEL GUIDE, BONDING WASHERS, DYNABOND EQUIPMENT OR OTHER APPROVED GROUNDING DEVICE.

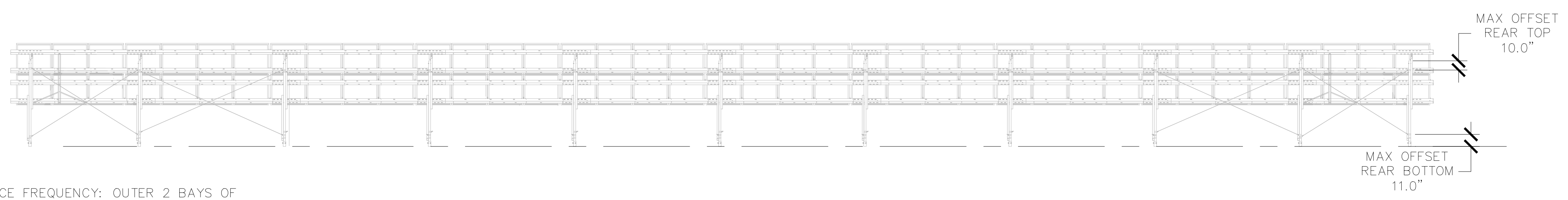

E1 REAR VIEW: CABLE BRACE FREQUENCY

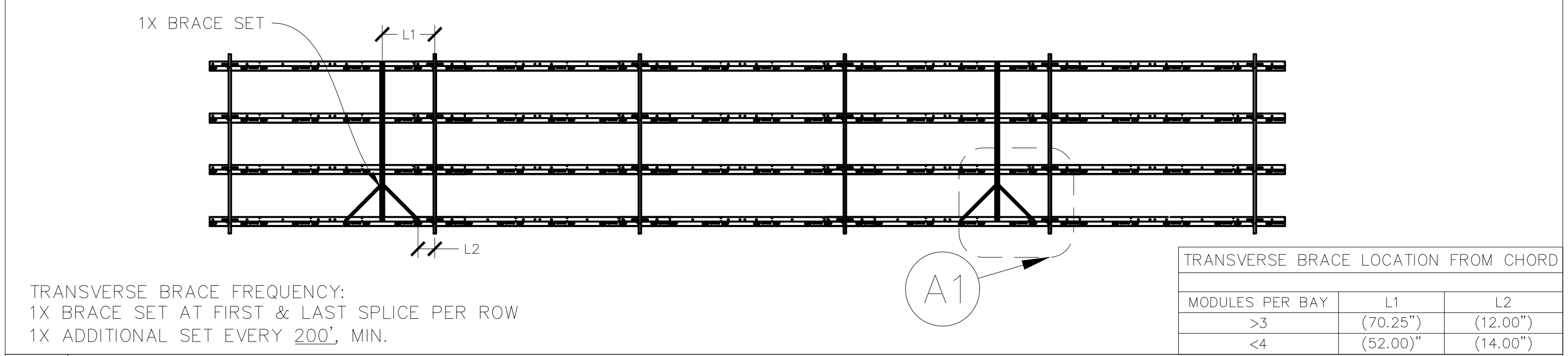

D1 BOTTOM VIEW: TRANSVERSE BRACE LOCATIONS

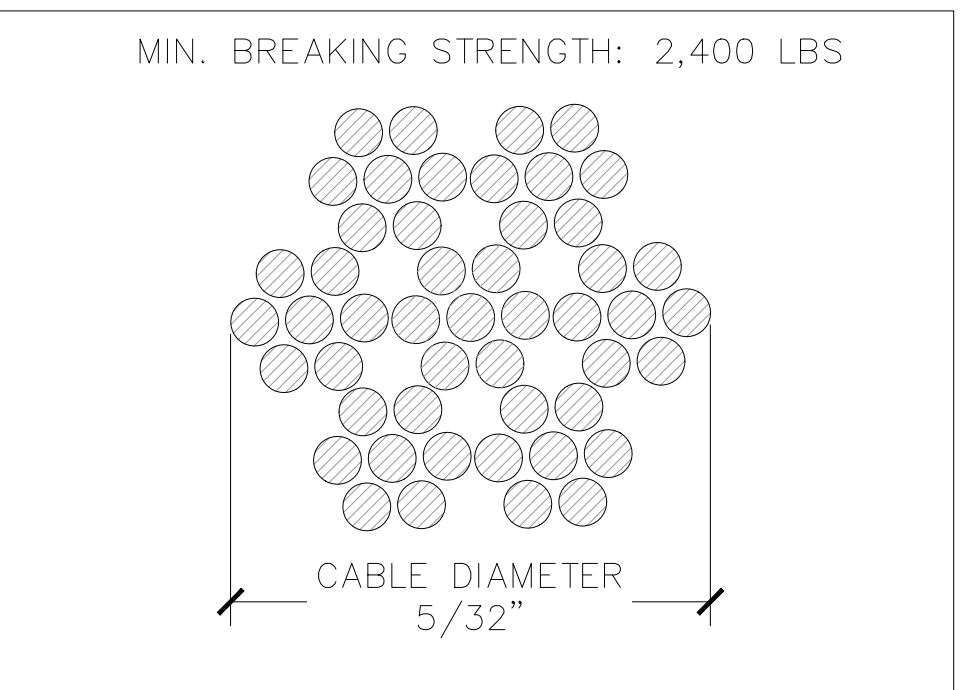

D4 SEC.: CABLE BRACE

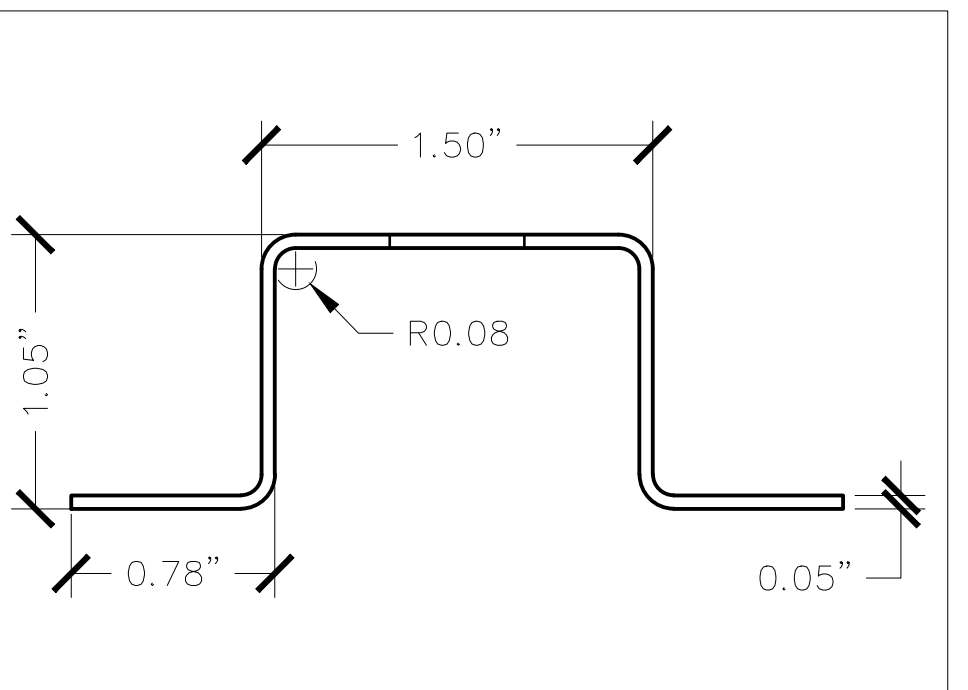

D5 SECTION: TVS BRACE

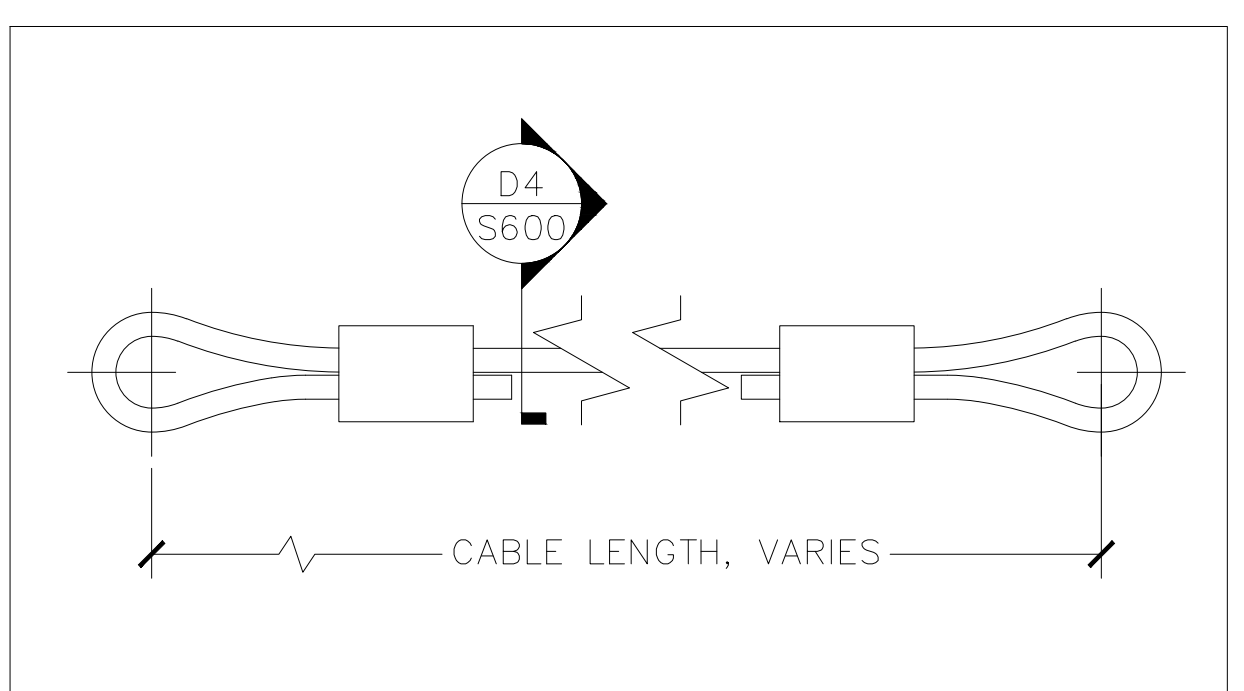

C1 PART: CABLE BRACE

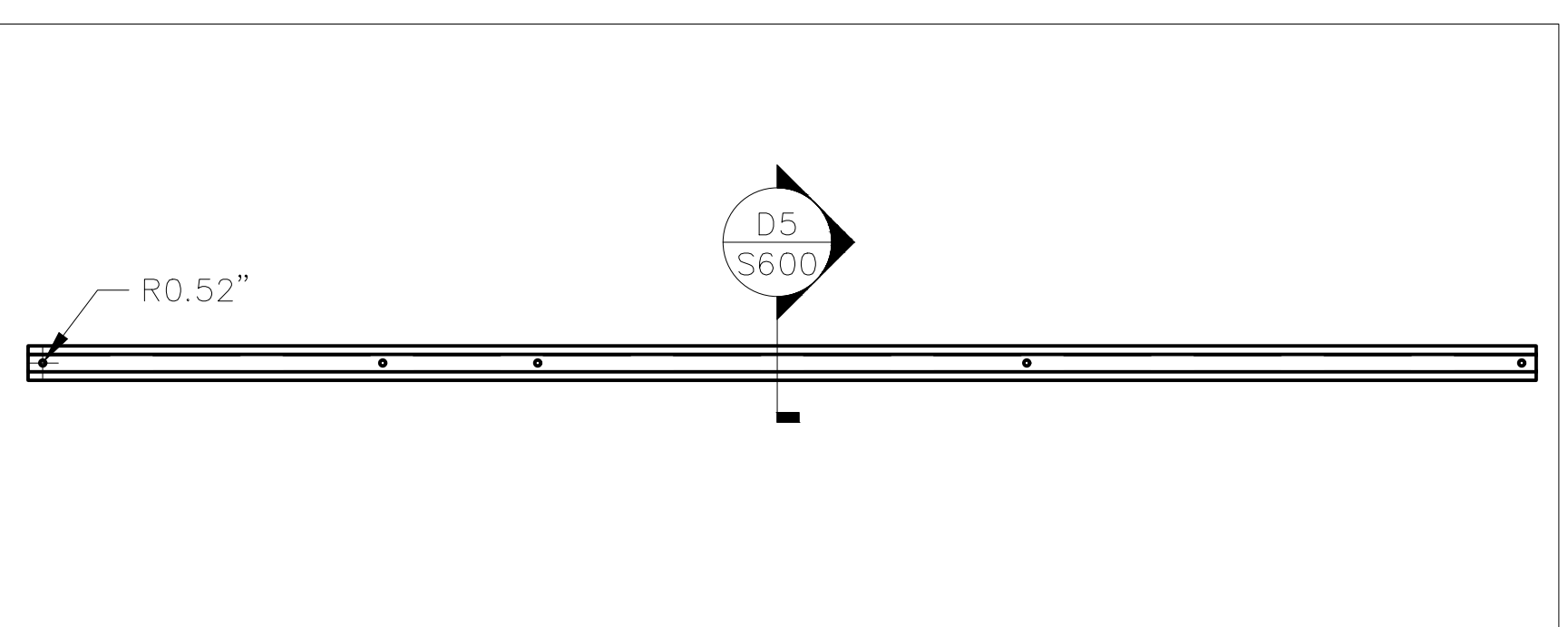

C2 PART: TRANSVERSE BRACE (TVS BRACE)

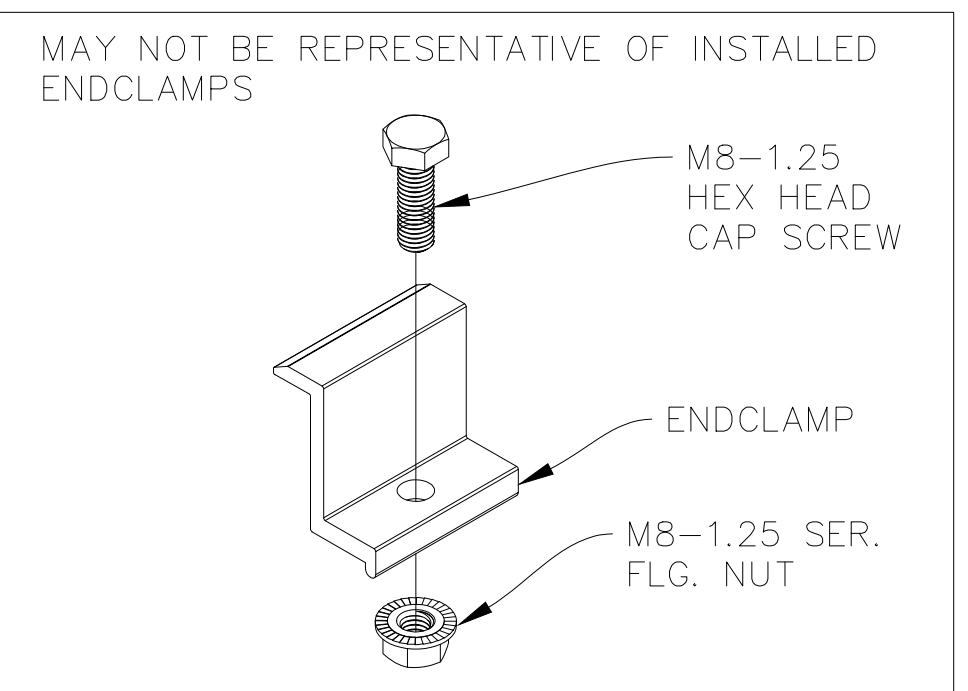

C4 ASSEMBLY: ENDCLAMP

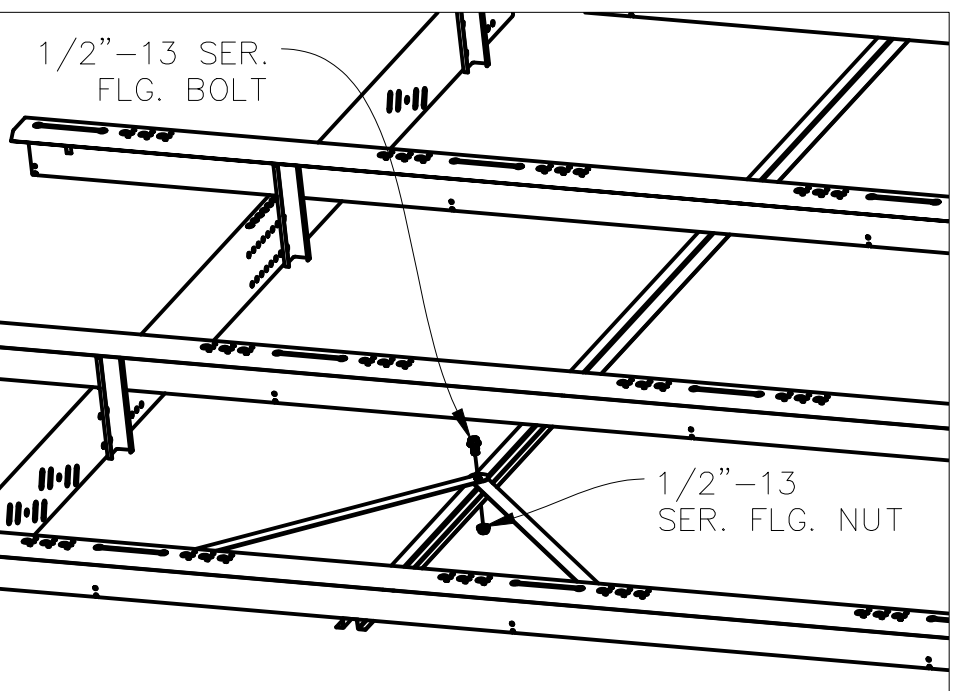

C5 TVS BRACE ASSEMBLY

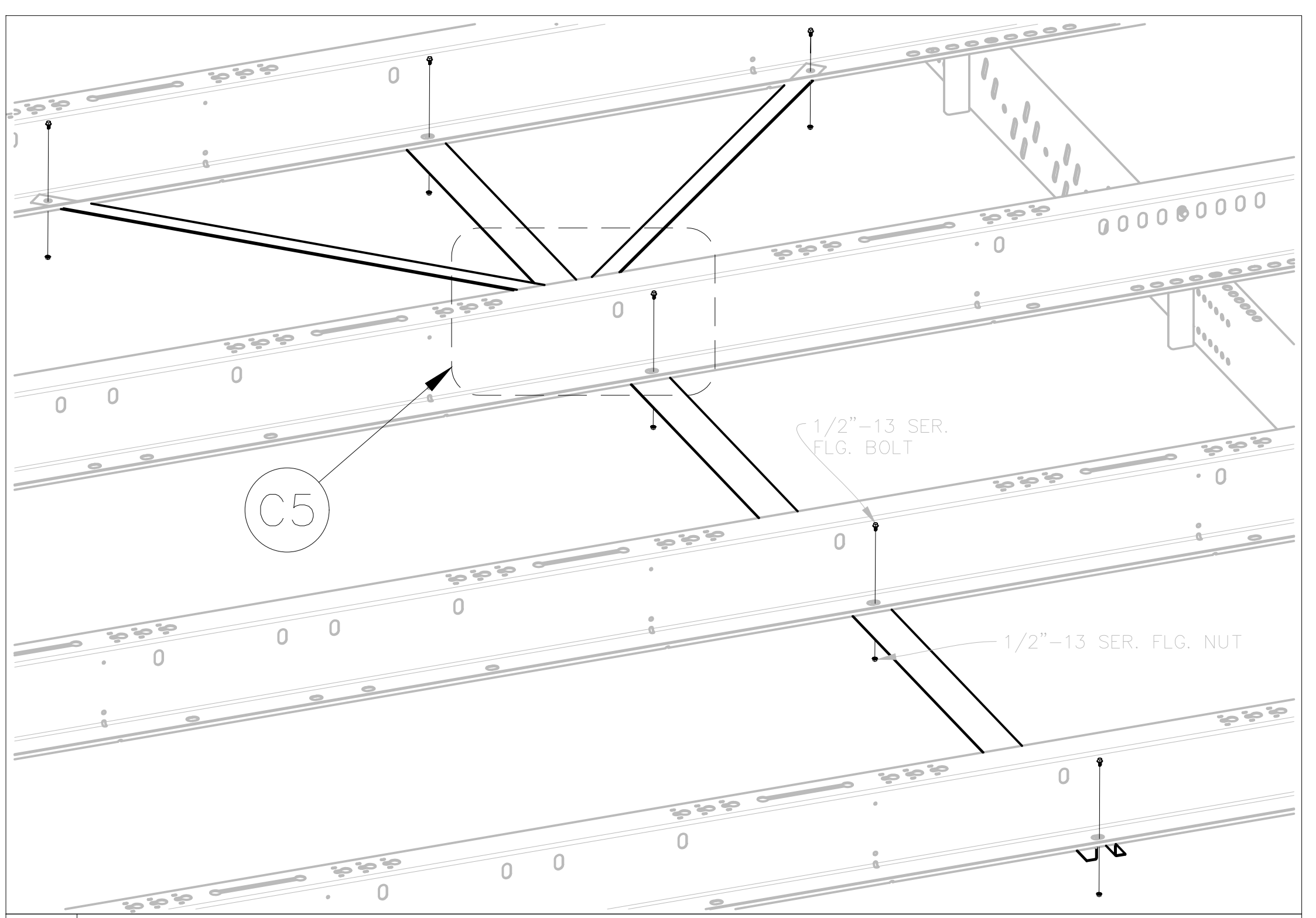

A1 CONNECTION: TVS BRACE-TO-PURLIN

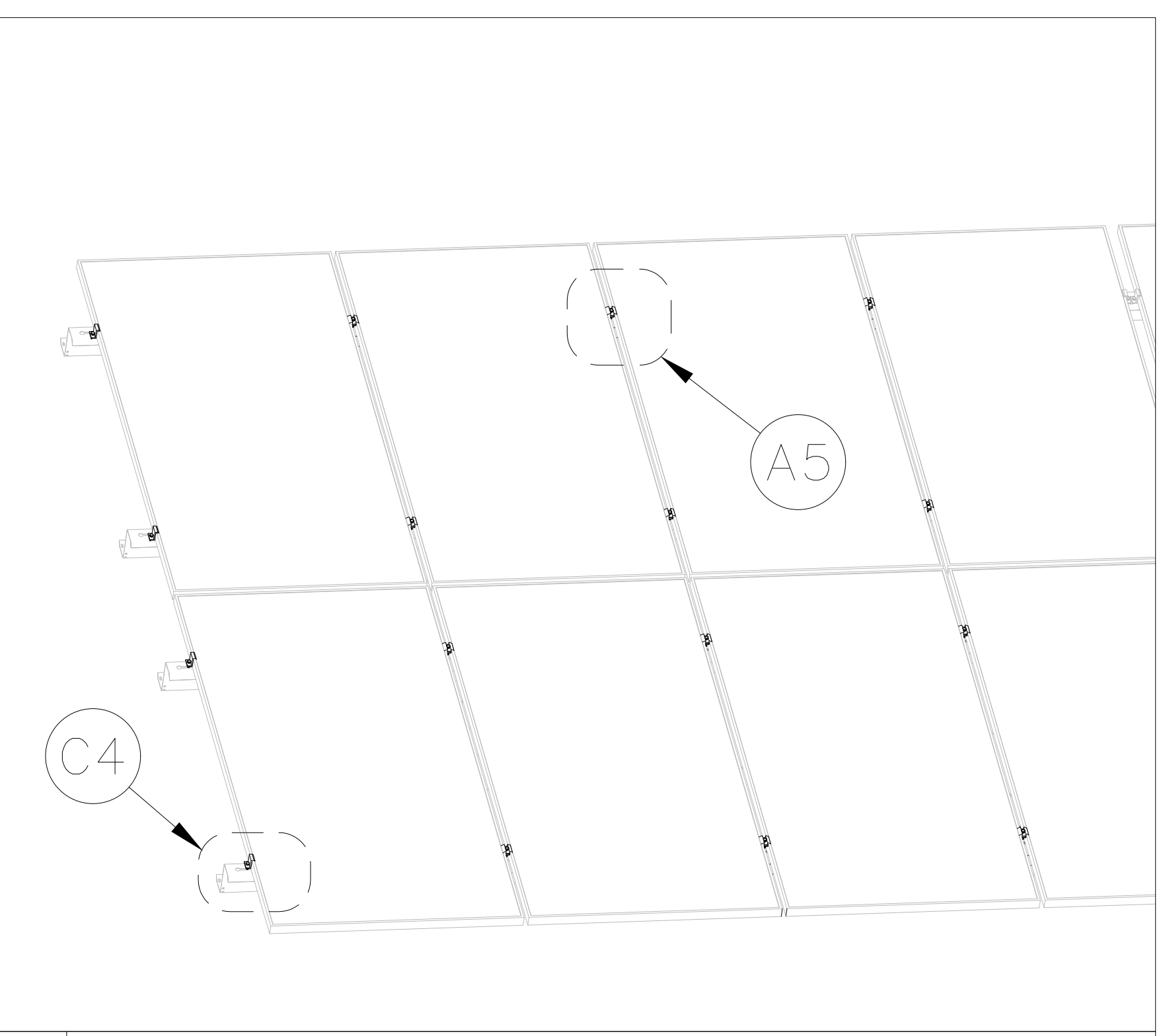

A3 TOP (ISO) VIEW: PV CLAMP LOCATIONS

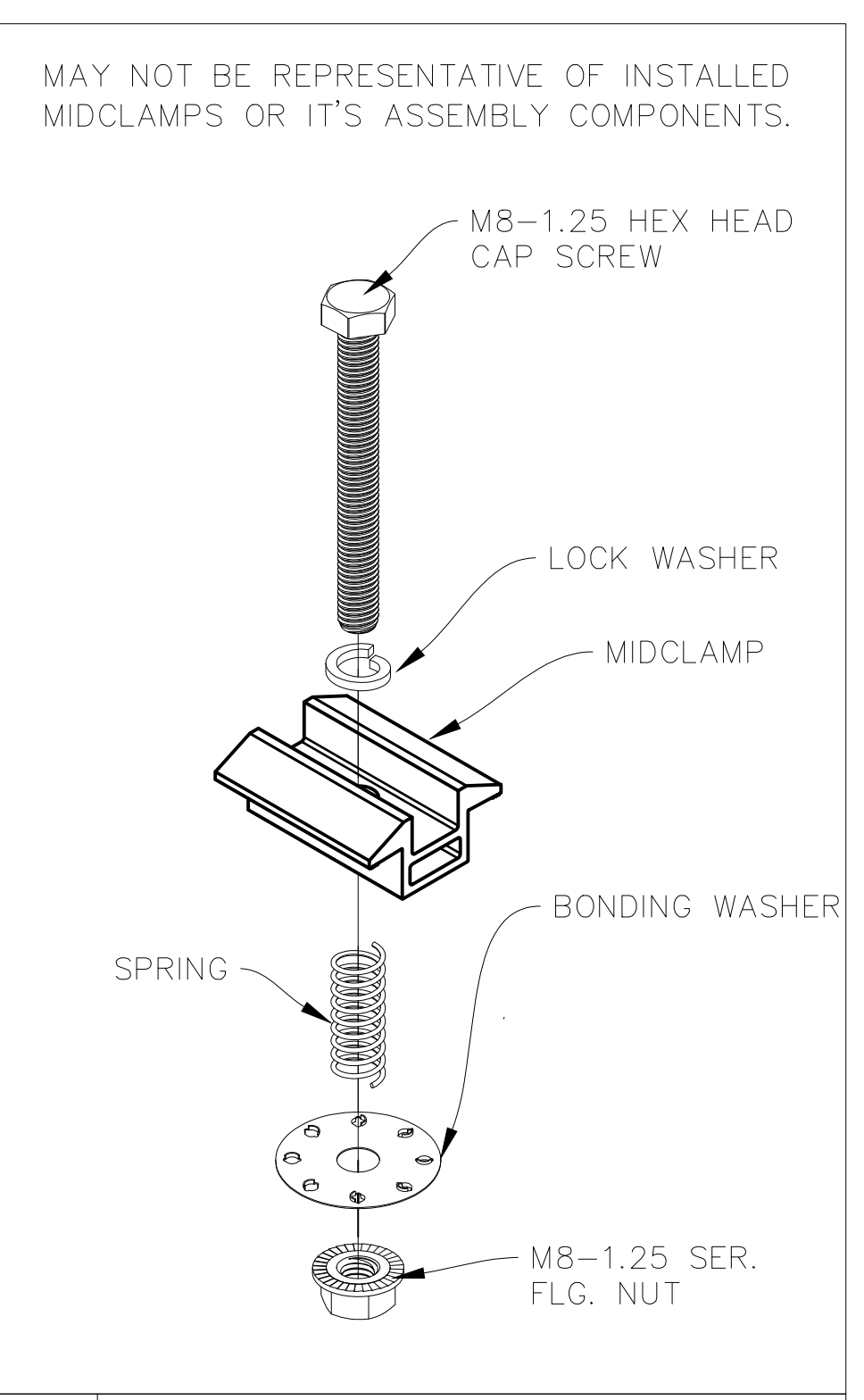

A5 ASSEMBLY: MIDCLAMP